



## **REQUEST FOR PROPOSALS**

RFP Number: FH-2024-03-01

for

## **Ford Heights Water System Improvement Project Phase II**

**BID NUMBER:** FH-2024-03-01  
**BID ISSUE DATE:** Monday, March 25, 2024  
**QUESTIONS DUE:** Wednesday, April 3, 2024 by 5:00 p.m. (Central Time)  
**BID DUE:** Tuesday, April 9, 2024, at 10:00 a.m. (Central Time)  
**BID OPENING DATE:** Tuesday, April 9, 2024, at 10:01 a.m. (Central Time)

# FORM 4B. INVITATION TO BID

## FORD HEIGHTS WATER SYSTEM IMPROVEMENTS PHASE II

### VILLAGE OF FORD HEIGHTS

NOTICE IS HEREBY GIVEN by the President and Board of Trustees of the Village of Ford Heights, Cook County, Illinois, that sealed bids will be received for the following improvement(s):

Ford Heights Water System Improvement Project Phase II  
CDBG Project #2207-009

Said bids will be received up to the hour of 10:00 A.M., Central Standard Time, on the 9<sup>th</sup> day of April 2024. Bids must be delivered to 1343 Ellis Ave, Ford Heights, IL 60411 ATTN: Village Clerk, in a sealed envelope with "Ford Heights Water System Improvements Phase II – [COMPANY NAME]" clearly labeled on the front of the envelope. Bids will be opened and publicly read at 10:01 a.m. CST on Tuesday, April 9, 2024, at Village Hall.

The bidding forms and documents are available at the office of 1343 Ellis Ave, Ford Heights, IL 60411, the Village's website [www.villageoffordheights.com](http://www.villageoffordheights.com), or by emailing [procurement@anterogroup.com](mailto:procurement@anterogroup.com). Proposals must be submitted on the forms provided. No bidding documents will be issued to bidders after 4:00 P.M., on the 8<sup>th</sup> day of April 2024. All proposals or bids offered must be accompanied by a bid bond, cash, or check made payable to the Village of Ford Heights in the amount of not less than ten percent (10%) of the total amount of the proposal as a guarantee that if the proposal is accepted, a contract will be entered into, and the performance of the contract is properly secured.

No bid shall be withdrawn after the opening of the proposals without consent of the Mayor and the Board of Trustees of the Village of Ford Heights for a period of forty-five (45) days after the scheduled time of closing bids.

The bidder is specifically advised that the Village of Ford Heights is a Subrecipient of the County of Cook of a grant made pursuant to the Housing and Community Development Act of 1974, as amended, pursuant to an agreement entered into and between the County of Cook and the Village of Ford Heights only after it has received the funds to make such payments of the aforesaid agreement. Further, in compliance with the Stevens Amendment to the Department of Defense Appropriations Act of 1989, the (estimated/actual) percentage of the total cost of the project to be funded by federal dollars is (60%) and the exact dollar amount of federal funds which will be set aside for this project will be based on the contract amount awarded under this offering.

#### APPLICABLE FEDERAL REQUIREMENTS

All laborers and mechanics employed by the Contractor or Subcontractor(s) on construction work for this Project shall be paid wages at rates not less than those prevailing on similar construction in the locality as determined by the Secretary of Labor in accordance with the Davis-Bacon Act, as amended, (U.S.C. Sections 76-276a-5), and shall receive overtime compensation in accordance with and subject to the provisions of the Contract Work Hours and Safety Standards Act (40 U.S.C. Sections 327-333), and the Contractor and Subcontractor(s) shall comply with all regulations issued pursuant to these Acts



and other applicable Federal laws and regulations pertaining to labor standards. The Secretary of Labor has, with respect to the labor standards specified in this Section, the authority and functions set forth in Reorganization Plan Number 14 of 1950 (5 U.S.C. Section 133z-15) and Section 2 of the Act of June 13, 1934, as amended, (40 U.S.C. Section 276c).

All contracts and Subrecipients for the construction or repair shall include a provision for compliance with the Copeland "Anti-Kickback Act" (18 U.S.C. Section 874) as supplemented in Department of Labor Regulations (29 CFR Part 3).

Each bidder is required to comply with Equal Employment Opportunity for the Community Development Block Grants, a copy of which is on file with the Village Clerk and is available for inspection.

Each bidder is required to be registered in the Federal Government databank for contractors at SAM.gov and have an active Unique Entity Identifier (UEI) number in the system.

Each bidder is required to comply with the Build America, Buy America Act (HUD proposes a waiver for infrastructure projects whose total is an amount equal to or less than \$250,000.00).

Compliance with "Section 3", which calls for affirmative action by the Contractor to train and/hire lower income residents of the Project area and to subcontract with local, small businesses is required on this Project.

An explanation of the applicable federal requirements previously mentioned is provided in the Special Provisions of the Bid Specifications and Davis-Bacon Packet.

The successful bidder for the construction of the improvement will be required to file a performance bond equal to one hundred percent (100%) of the bid, with sureties to be approved by the Mayor and the Board of Trustees, which performance bonds shall be conditioned upon proper and faithful performance by the Contractor of the work specified in accordance with the plans and specifications therefore, according to the time and terms and conditions of the contract; and also that the bidder and contractor shall properly pay all debts incurred by the Contractor in the execution of the work, including those for labor and materials furnished.

The Contractor shall be required to furnish sufficient insurance or guaranty of indemnity to the Village of Ford Heights, Illinois, and the County of Cook, Illinois, against any and all claims which might arise for damages to persons or property due to the negligence of the Contractor or Subcontractor(s), or their officers, agents, employees or servants, during the construction/demolition of said improvement and until the said improvement has been finally accepted as complete by the Mayor and the Board of Trustees of the Village of Ford Heights, the right to reject any and all proposals or bids is reserved.

Dated at Ford Heights, Illinois this Wednesday, March 20, 2024.

Mayor and Board of Trustees of Village of Ford Heights

By: Charles Griffin, Mayor

Attest: Nyree Ford, Village Clerk



# 1. GENERAL INFORMATION FOR THE BIDDER

## 1.1. Introduction

The Village of Ford Heights (“Village”) received funding through the Community Development Block Grant (CDBG) to implement the Ford Heights Water System Improvement Project Phase II. The first phase of this project was completed in 2023 and addressed priority fire hydrant and water valve replacement. This project seeks to continue the efforts from Phase I to complete additional priority repairs and replacements of the water system and roadways. These water system repairs will help to improve the functionality of the Ford Heights water distribution system and reduce wasted resources while the road resurfacing work will prolong the life span of 13th Street from Cottage Grove Avenue to Woodlawn Avenue. This fire hydrant replacement, and spot water main repair, and road improvement project is a part of a larger effort to repair the water system throughout the Village in order to ensure water can safely be provided to the residents and users in the area. This RFP applies to only fire hydrant replacement, leak repair, and road resurfacing work.

## 1.2. Scope of Work

The Project Area for this scope of work is generally on 13<sup>th</sup> Street between Cottage Grove Avenue and Woodlawn Avenue. The Scope of Work as part of this Solicitation is to remove two (2) fire hydrants, remove and replace two (2) fire hydrants, locate and repair two (2) water main leaks, and resurface approximately 2,480 linear feet of road using four-inch (4-in) mill and resurface. The plans and specifications of this work are in **Appendix C**.

## 1.3. Bid Requirements

Bidders are to follow the following bid requirements when submitting proposals:

1. Bids will be accepted until 10:00 a.m. CST on Tuesday, April 9, 2024. Bids must be delivered to 1343 Ellis Ave, Ford Heights, IL 60411 ATTN: City Clerk, in a sealed envelope with “Ford Heights Water System Improvements Phase II – [COMPANY NAME]” clearly labeled on the front of the envelope.
2. All certifications outlined in **Appendix A**. Special Provisions must be signed and submitted at the time of bid, including:
  - a. Equal Employment Opportunity Certification
  - b. Certification of Bidder Regarding Equal Employment Opportunity
  - c. Debarment and Suspension Certification
  - d. Certification Regarding Lobbying
3. **Appendix D** bid form must be filled out.
4. A 10% bid bond shall be submitted with each proposal, as a guarantee that, if the proposal is accepted, a contract will be entered into.

## 1.4. Bid Submission

Proposals are due by 10:00 a.m. CST on Tuesday, April 9, 2024. Bids must be delivered to 1343 Ellis Ave, Ford Heights, IL 60411 ATTN: City Clerk, in a sealed envelope with “Ford Heights Water System Improvements Phase II – [COMPANY NAME]” clearly labeled on the front of the envelope. Bids will be publicly opened and read aloud the same day, Tuesday,



April 9, 2024, at 10:01 a.m. (Central Time) at Ford Heights' Village Hall. All bidders are invited to participate.

### 1.5. RESPONSE TO BIDDER QUESTIONS

Explanations desired by a prospective bidder shall be requested of the Village by email, and if explanations are necessary, a reply shall be made in the form of an addendum, a copy of which will be forwarded to known bidders. Every request for such explanation shall be submitted by email to [procurement@anterogroup.com](mailto:procurement@anterogroup.com) by Wednesday, April 3, 2024 by 5:00 p.m. (Central Time). No inquiry or request received after this deadline will be given consideration.

### 1.6. OTHER INFORMATION

The right is reserved to reject any or all proposals, to waive technicalities, to postpone the bid opening, or to advertise for new proposals, if in the judgment of the mayor and Board of Trustees their best interests will be promoted thereby. The Village also reserves the right to rescind any awarded contract if grant funding is no longer available to support this project.

The contractor will be required to pay not less than the Cook County prevailing wage rates on this project as established by the Illinois Department of Labor. The prevailing wage rates are available on the Illinois Department of Labor's official website. It is the responsibility of the contractor to obtain and comply with any revisions to the rates should they change throughout the duration of this Agreement.

Prequalification will be required to be submitted to the Village by all potential bidders. If in the opinion of the Mayor and Board of Trustees, an applicant would not be able to serve the best interest of the Village, a proposal will not be issued to the applicant.

All certifications outlined in **Appendix B**. Davis-Bacon Construction Packet must be signed and submitted to the sub-recipient or the designated representative.

1. Contractor and Subcontractor Certifications
2. Contract and Subcontract Activity Form (HUD-2516)
3. Weekly Payroll and Statement of Compliance, due within seven (7) days from the close of each pay week
4. Record of Employee Interview Form (HUD-11), to be completed by the subrecipient or its designated representative during the course of the construction and due at project close out

A performance bond in a sum equal to one hundred percent (100%) of the amount of the bid, with sureties to be approved by the Mayor and Board of Trustees for the faithful performance of the contract, must be furnished by the successful bidder. All bids or proposals shall contain an offer to furnish bond upon acceptance of such bid or proposal.

Federal requirements as outlined in the Invitation to Bid and attached are provided in **Appendix A** and **Appendix B**.

## 2. BID SPECIFICATIONS

Bid specifications are provided in **Appendix C**.

## 3. BID FORM

The bid form is provided in **Appendix D**.



# **APPENDIX A**

**(Special Provisions for Federally & Cook County  
CDBG Funded Projects)**





---

# SPECIAL PROVISIONS

---

For Federal-Funded  
& Cook County CDBG-  
Funded Projects (\*Rev 3/08/2024)

---

## TABLE OF CONTENTS

<u>SUBJECT</u>	<u>PAGE</u>
<b>EQUAL EMPLOYMENT OPPORTUNITY</b>	<b>03 - 11</b>
- <i>Notice of Requirement for Affirmative Action to Ensure EEO</i>	
- <i>Equal Opportunity Clauses</i>	
- <i>Standard Federal Equal Employment Opportunity Construction Contract Specs</i>	
<b>SECTION 3 CLAUSE</b>	<b>12</b>
<b>*SECTION 3 – FINAL RULE</b> <i>(Only applicable for contracts over \$200K)</i>	<b>13 - 16</b>
- <i>Purpose, Background, Applicability, Labor Hours, Documenting Compliance</i>	
<b>LABOR STANDARDS</b>	<b>17 - 18</b>
- <i>Davis-Bacon Act (DBA)</i>	
- <i>Contract Work Hours and Safety Standards Act (CWHSSA)</i>	
- <i>Copeland Act (Anti-Kickback Act)</i>	
- <i>Fair Labor Standards Act (FLSA)</i>	
<b>Other Provisions &amp; Required Performance</b>	
- <i>Clean Air Act of 1970 and The Federal Water Pollution Control Act Provision</i>	
- <i>Architectural Barriers Act of 1968 Provision</i>	
- <i>Record Keeping and Inspections</i>	
<b>STANDARD ADMINISTRATION DEPARTMENT OF LABOR EMPLOYMENT MINIMUM WAGES FOR FEDERAL &amp; FEDERALLY ASSISTED CONST.</b>	<b>19 - 20</b>
- <i>General Wage Determination Decisions</i>	
- <i>Modifications &amp; Supersedes to General Wage Determination Decisions</i>	
- <i>New General Wage Determination Decisions</i>	
<b>*BUILD AMERICA, BUY AMERICA ACT (BABAA) –</b> <i>(Only applicable for contracts over \$250K)</i>	<b>21 - 22</b>

### **ADDITIONAL REQUIRED ATTACHMENTS:**

FEDERAL LABOR STANDARDS PROVISIONS (Attachment)

SPECIAL PROVISIONS FOR MINORITY & WOMEN BUSINESS ENTERPRISE (Attachment)

### **REQUIRED CERTIFICATIONS:**

Equal Employment Opportunity Certification

Certification of Bidder Regarding Equal Employment Opportunity

Debarment & Suspension Certification

Certificate Regarding Lobbying

All certifications listed above **MUST** be signed and submitted at the time of bid or the bid can be disqualified.

***\*Each bidder is required to be registered in the Federal Government databank for contractors at SAM.gov and have an active "Unique Entity Identifier (UEI)" number in the system.***

*The following Special Provisions should be used for all construction bids and contracts where federal grant funds are being used in whole or in part.*



**EQUAL EMPLOYMENT OPPORTUNITY  
41 CFR Chapter 60**

The following notice shall be included in, and shall be a part of all solicitations for offers and bids on all Federal and federally assisted construction contracts or subcontracts in excess of \$10,000 to be performed in geographical areas designated by the Director pursuant to § 60-4.6 of this part (see 41 CFR 60-4.2 (a):

**Notice of Requirement for Affirmative Action to Ensure Equal  
Employment Opportunity (Executive Order 11246)**

1. The Offer's or Bidder's attention is called to the "Equal Opportunity Clause" and the "Standard Federal Equal Employment Opportunity Construction Contract Specifications" set forth herein.
2. The goals and timetables for minority and female participation, expressed in percentage terms for the Contractor's aggregate workforce in each trade on all construction work in the covered area are as follows:

TRADE	TIMETABLE	GOALS FOR MINORITY PARTICIPATION FOR EACH TRADE		GOALS FOR FEMALE PARTICIPATION IN EACH TRADE	
		TRADE	TIMETABLE	TRADE	TIMETABLE
Asbestos Workers	Until Further Notice	8.6 to 10.3	4/1/7 - 3/31/8	5.0	
Bricklayers	"	16.3 to 18.2	"	"	"
Carpenters	"	11.0 to 18.2	"	"	"
Electricians	"	10.9 to 12.2	"	"	"
Elevator Installers	"	9.6 to 11.5	"	"	"
Glaziers	"	10.2 to 12.2	"	"	"
Ironworkers	"	14.0 to 16.0	"	"	"
Metal Lathers	"	10.0 to 12.0	"	"	"
Painters	"	10.3 to 12.1	"	"	"
Plumbers	"	9.4 to 10.9	"	"	"
Pipefitters	"	9.4 to 10.9	"	"	"
Plasterers	"	24.4 to 25.8	"	"	"
Roofers	"	18.0 to 20.0	"	"	"
Sheetmetal Workers	"	9.5 to 11.3	"	"	"
Sprinkler Fitters	"	8.3 to 9.9	"	"	"
Operating Engineers	"	15.7 + above	"	"	"

These goals are applicable to all the Contractor's construction Work (whether or not it is Federal or federally assisted) performed in the coverage area. The contractor's compliance with the Executive Order and the regulations in 41 CFR Part 60-4 shall be based on its implementation of the Equal Opportunity Clause, specific affirmative action obligations required by the specifications set forth in 41 CFR 60-4.3 (a), and its efforts to meet the goals established for the geographical area where the Contract resulting from this solicitation is to be performed. The hours of minority and female employment and training must be substantially uniform throughout the length of the Contract, and in each trade, and the Contractor shall make a good faith effort to employ minorities and women evenly on each of its projects. The transfer of minority or female employees or trainees from Contractor to Contractor or from project to project for the sole purpose of meeting the Contractor's goals shall be a violation of the

Contract, the Executive Order and the regulations in 41 CFR Part 60-4. Compliance with the goals will be measured against the total work hours performed.

3. The Contractor shall provide written notification to the Director of the Office of Federal Contract Compliance Programs within 10 working days of award of any construction subcontract in excess of \$10,000 at any tier for construction work under the Contract resulting from this solicitation. The notification shall list the name, address and telephone number of the subcontractor; employer identification number; estimated dollar amount of the subcontract; estimated starting and completion dates of the subcontract; and the geographical area in which the Contract is to be performed.
4. As used in this Notice, and in the Contract resulting from this solicitation, the "covered area." Is the State of Illinois, County of Cook.

### **Equal Opportunity Clauses**

41 CFR 60-1.4(a)

During the performance of this Contract, the Contractor agrees as follows:

1. The Contractor will not discriminate against any employee or applicant for employment because of race, color, religion, sex, or national origin. The Contractor will take affirmative action to ensure that applicants are employed, and that employees are treated during employment, without regard to their race, color, religion, sex, or national origin. Such action shall include, but not be limited to the following: employment, upgrading, demotion, or transfer; recruitment or recruitment advertising; layoff or termination; rates of pay or other forms of compensation; and selection for training, including apprenticeship. The Contractor agrees to post in conspicuous places, available to employees and applicants for employment, notices to be provided by the contracting officer setting forth the provisions of this nondiscrimination clause.
2. The Contractor will, in all solicitations or advertisements for employees placed by or on behalf of the Contractor, state that all qualified applicants will receive consideration for employment without regard to race, color, religion, sex, or national origin.
3. The Contractor will send each labor union or representative of workers with which he has a collective bargaining agreement or other Contract or understanding, a notice, to be provided by the agency contracting officer, advising the labor union or worker's representative of the Contractor's commitments under Section 202 of Executive Order No. 11246 of September 24, 1965, and shall post copies of the notice in conspicuous places available to employees and applicants for employment.
4. The Contractor will comply with all provisions of Executive Order No. 11246 of September 24, 1965, and of the rules, regulations, and relevant order of the Secretary of Labor.
5. The Contractor will furnish all information and reports required by the Executive Order No.11246 of September 24, 1965, and by the rules, regulations, and orders of the Secretary of Labor, or pursuant thereto, and will permit access to his books, records, and accounts by the Department and the Secretary of Labor for purposes of investigation to ascertain compliance with such rules, regulations, and orders.

6. In the event of the Contractor's noncompliance with the nondiscrimination clauses of this Contract or with any of such rules, regulations, or orders, this Contract may be cancelled, terminated or suspended in whole or in part and the Contractor may be declared ineligible for further Government Contracts in accordance with procedures authorized in Executive Order No. 11246 of September 24, 1965, and such other sanctions may be imposed and remedies invoked as provided in Executive Order No. 11246 of September 24, 1965, or by rules, regulations, or orders of the Secretary of Labor, or as otherwise provided by law.
7. The Contractor will include the provisions of Paragraphs (1) through (7) in every subcontract purchase order unless exempted by rules, regulations, or orders of the Secretary of Labor issued pursuant to Section 204 of Executive Order No. 11246 of September 24, 1965, so that such provisions will be binding upon each subcontractor or vendor. The Contractor will take such action with respect to any subcontract or purchase order as the contracting agency may direct as a means of enforcing such provisions including sanctions for noncompliance: Provided, however, that in the event the Contractor becomes involved in, or is threatened with, litigation with a subcontractor or vendor as a result of such direction by the contracting agency, the Contractor may request the United States to enter into such litigation to protect the interests of the United States. 41 CFR 60-1.4(b)

The Applicant hereby agrees that it will incorporate or cause to be incorporated into any Contract for Construction Work or modification thereof, as defined in the regulations of the Secretary of Labor at 41 CFR Chapter 60, which is paid for in whole or in part with funds obtained from the Federal Government or borrowed on the credit of the Federal Government pursuant to a grant, Contract, loan, insurance, or guarantee, or undertaken pursuant to any Federal program involving such grant, Contract, loan, insurance, or guarantee, the following equal opportunity clause:

During the performance of this Contract, the Contractor agrees as follows:

1. The Contractor will not discriminate against any employee or applicant for employment because of race, color, religion, sex, or national origin. The Contractor will take affirmative action to ensure that applicants are employed, and that employees are treated during employment, without regard to their race, color, religion, sex, or national origin. Such action shall include, but not be limited to, the following: Employment, upgrading, demotion, or transfer; recruitment or recruitment advertising; layoff or termination; rates of pay or other forms of compensation; and selection for training, including apprenticeship. The Contractor agrees to post in conspicuous places, available to employees and applicants for employment, notices to be provided setting forth the provisions of this nondiscrimination clause.
2. The Contractor will, in all solicitations or advertisements for employees placed by or on behalf of the Contractor, state that all qualified applicants will receive consideration for employment without regard to race, color, religion, sex, or national origin.
3. The Contractor will send to each labor union or representative of workers with which he has a collective bargaining agreement or other Contract or understanding, a notice to be provided by the Contract Compliance Officer advising the said labor union or worker's representatives of the Contractor's commitment under this section and shall post copies of the notice in conspicuous places available to employees and applicants for employment.
4. The Contractor will comply with all provisions of Executive Order 11246 of September 24, 1965, and by rules, regulations and orders of the Secretary of Labor.
5. The Contractor will furnish all information and reports required by Executive Order 11246 of September 24, 1965, and by rules, regulations and orders of the Secretary of Labor, or pursuant thereto, and will permit access to his books, records, and accounts by the Department and the Secretary of Labor for purposes of investigation to ascertain compliance with such rules,

regulations, and orders.

6. In the event of the Contractor's noncompliance with the nondiscrimination clauses of this Contract or with any of the said rules, regulations, or orders, this Contract may be cancelled, terminated, or suspended in whole or in part and the Contractor may be terminated, or suspended in whole or in part and the Contractor may be declared ineligible for further Government Contracts or federally assisted construction contracts in accordance with procedures authorized in Executive Order 11246 of September 24, 1965, or by rule, regulation, or order of the Secretary of Labor, or as otherwise provided by law.
7. The Contractor will include the portion of the sentence immediately preceding paragraph (1) and the provisions of paragraphs (1) through (7) in every subcontract or purchase order unless exempted by rules, regulations, or orders of the Secretary of labor issued pursuant to Section 204 of Executive Order 11246 of September 24, 1965, so that such provisions will be binding upon each subcontractor or vendor. The Contractor will take such action with respect to any subcontract or purchase order as the Department may direct as a means of enforcing such provisions, including sanctions for noncompliance, provided, however, that in the event a contractor becomes involved in, or is threatened with, litigation with a subcontractor or vendor as a result of such direction by the Department, the Contractor may request the United States to enter such litigation to protect the interest of the United States.

The applicant further agrees that it will be bound by the above equal opportunity clause with respect to its own employment practices when it participates in federally assisted construction work, provided that if the applicant so participating is a State or local government, the above equal opportunity clause is not applicable to any agency, instrumentality or subdivision of such government which does not participate in work on or under the Contract.

The applicant agrees that it will assist and cooperate actively with the Department and the Secretary of Labor in obtaining the compliance of Contractors and subcontractors, with the equal opportunity clause and rules, regulations, and relevant orders of the Secretary of Labor; that it will furnish the Department and the Secretary of Labor such information as they may require for the supervision of such compliance; and that it will otherwise assist the Department in the discharge of its primary responsibility for securing compliance.

The applicant further agrees that it will refrain from entering into any contract or contract modification subject to Executive Order 11246 of September 24, 1965, with a contractor debarred from, or who has not demonstrated eligibility for, Government contracts and federally assisted construction contracts pursuant to the Executive order and will carry out such sanctions and penalties for violation of the equal opportunity clause as may be imposed upon contractors and subcontractors by the Department or the Secretary of Labor pursuant to Part II, Subpart D of the Executive order. In addition, the applicant agrees that if it fails or refuses to comply with these undertakings, the Department may take any or all of the following actions: Cancel, terminate, or suspend in whole or in part this grant (contract, loan, insurance, guarantee); refrain from extending any further assistance to the applicant under the program with respect to which the failure or refusal occurred until satisfactory assurance of future compliance has been received from such applicant; and refer the case to the Department of Justice for appropriate legal proceedings.

In addition to the clauses described above, all Federal contracting officers, all applicants and all non-construction contractors, as applicable, shall include the specifications set forth in this section in all Federal and federally assisted construction contracts in excess of \$10,000 to be performed in geographical areas designated by the Director pursuant to \$10,000 necessary in whole or in part to

the performance of non-construction Federal contracts and subcontracts covered under the Executive Order.

**Standard Federal Equal Employment Opportunity Construction Contract  
Specifications (Executive Order 11246)**

1. As used in these specifications:
  - a. "Covered Area means the geographical area described in the solicitation from which this Contract resulted;
  - b. "Director" means Director, Office of Federal Contract Compliance Programs, United States Department of Labor, or any person to whom the Director delegates authority;
  - c. "Employer Identification Number" means the Federal Social Security number used on the Employer's Quarterly Federal Tax Return, U.S. Treasury Department Form 941.
  - d. "Minority" includes:
    - I. Black (all persons having origins in any of the Black African racial groups not of Hispanic origin);
    - II. Hispanic (all persons of Mexican, Puerto Rican, Cuban, Central or South American or other Spanish Culture or origin, regardless of race);
    - III. Asian and Pacific Islander (all persons having origins in any of the original peoples of the Far East, Southeast Asia, the Indian Subcontinent, or the Pacific Islands); and
    - IV. American Indian or Alaskan Native (all persons having original peoples of North American and maintaining identifiable tribal affiliations through membership and participation or community identification).
2. Whenever the Contractor, or any subcontractor at any tier, subcontracts a portion of the work involving any construction trade, it shall physically include in each subcontract in excess of \$10,000 the provisions of these specifications and the Notice which contains the applicable goals for minority and female participation, and which is set forth in the solicitations from which this contract resulted.
3. If the Contractor is participating (pursuant to 41 CFR 60-4.5) in a Hometown Plan approved by the U.S. Department of Labor in the covered area either individually or through an association, its affirmative action obligations on all work in the Plan area (including goals and timetables) shall be in accordance with that Plan for those trades which have unions participating in the Plan. Contractors must be able to demonstrate their participation in and compliance with the provisions of any such Hometown Plan. Each and compliance with the provisions of any such Hometown Plan. Each contractor or subcontractor participating in an approved Plan is individually required to comply with its obligations under the EEO clause, and to make a good faith effort to achieve each goal under the Plan in each trade in which it has employees. The overall good faith performance by other contractors or subcontractors toward a goal in an approved Plan does not excuse any covered contractor's or subcontractor's failure to take good faith efforts to achieve the Plan and timetables.
4. The Contractor shall implement the specific affirmative action standards provided in paragraphs 7a through 7p of these specifications. The goals set forth in the solicitation from which this Contract resulted are expressed as percentages of the total hours of employment and training of minority and female utilization and Contractor should reasonably be able to achieve in each construction trade in which it has employees in the covered area. The Contractor is expected to make substantially uniform progress toward its goals in each craft during the period specified.

5. Neither the provisions of any collective bargaining agreement, nor the failure by a union with whom the Contractor has a collective bargaining agreement, to refer either minorities or women shall excuse the contractor's obligations under these specifications, Executive Order 11246, or the regulations promulgated pursuant thereto.
6. In order for the non-working training hours of apprentices and trainees to be counted in meeting the goals, such apprentices and trainees must be employed by the Contractor during the training period, and the Contractor must have made a commitment to employ the apprentices and trainees at the completion of their training, subject to the availability of employment opportunities. Trainees must be trained pursuant to training programs approved by the U.S. Department of Labor.
7. The Contractor shall take specific affirmative actions to ensure equal employment opportunity. The evaluation of the Contractor's compliance with these specifications shall be based upon its effort to achieve maximum results from its actions. The contractor shall document these efforts fully, and shall implement affirmative action steps at least as extensive as the following:
  - a. Ensure and maintain a working environment free of harassment, intimidation, and coercion at all sites, and in all facilities at which the Contractor's employees are assigned to work. The Contractor, where possible, will assign two or more women to each construction project. The Contractor shall specifically ensure that all foremen, superintendents, and other on-site supervisory personnel are aware of and carry out the Contractor's obligation to maintain such a working environment, with specific attention to minority or female individuals working at such sites or in such facilities.
  - b. Establish and maintain a current list of minority and female recruitment sources, provide written notification to minority and female recruitment sources and to community organizations when the Contractor or its unions have employment opportunities available, and maintain a record of the organization's responses.
  - c. Maintain a current file of the names, addresses and telephone numbers of each minority and female off-the-street applicant and minority or female referral from a union, a recruitment source or community organization and of what action was taken with respect to each such individual. If such individual was sent to the union hiring hall for referral and was not referred back to the Contractor by the union or, if referred, not employed by the Contractor, this shall be documented in the file with the reason therefore, along with whatever additional actions the Contractor may have taken.
  - d. Provide immediate written notification to the Director when the union or unions with which the Contractor has a collective bargaining agreement has not referred to the Contractor a minority person or woman sent by the Contractor, or when the Contractor has other information that the union referral process has impeded the Contractor's efforts to meet its obligations.
  - e. Develop on-the-job training opportunities and/or participate in training programs for the area which expressly include minorities and women, including upgrading programs and apprenticeship and trainee programs relevant to the Contractor's employment needs, especially those programs funded or approved by the Department of Labor. The Contractor shall provide notice of these programs to the sources compiled under 7b above.

- f. Disseminate the Contractor's EEO policy by providing notice of the policy to unions and training programs and requesting their cooperation in assisting the Contractor in meeting its EEO obligations; by including it in any policy manual and collective bargaining agreement; by publicizing it in the company newspaper, annual report, etc.; by specific review of the policy with all management personnel and with all minority and female employees at least once a year; and by posting the company EEO policy on bulletin boards accessible to all employees at each location where construction work is performed.
- g. Review, at least annually, the company's EEO policy and affirmative action obligations under these specifications with all employees having any responsibility for hiring, assignment, layoff, termination or other employment decisions including specific review of these items with onsite supervisory personnel such as Superintendents, General Foremen, etc. prior to the initiation of construction work at any job site. A written record shall be made and maintained identifying the time and place of these meetings, persons attending, subject matter discussed, and disposition of the subject matter.
- h. Disseminate the Contractor's EEO policy externally by including it any advertising in the news media, specifically including minority and female news median, and providing written notification to and discussing the Contractor's EEO policy with other contractors and subcontractors with whom the Contractor does or anticipates doing business.
- i. Direct its recruitment efforts, both oral and written, to minority female and community organizations, to schools with minority and female students and to minority and female recruitment and training organizations serving the Contractor's recruitment area and employment needs. Not later than one month prior to the date for the acceptance of applications for apprenticeship or other training by any recruitment source, the Contractor shall send written notification to organizations such as the above, describing the opening, screening procedures, and tests to be used in the selection process.
- j. Encourage present minority and female employees to recruit other minority persons and women and, where reasonable, provide after school, summer and vacation employment to minority and female youth both on the site and in other areas of a Contractor's workforce.
- k. Validate all tests and other selection requirements where there is an obligation to do so under 41 CFR Part 60-3.
- l. Conduct, at least annually, an inventory and evaluation at least of all minority and female personnel for promotional opportunities and encourage these employees to seek or to prepare for, through appropriate training, etc., such opportunities.
- m. Ensure that seniority practices, job classifications, work assignments and other personnel practices, do not have a discriminatory effect by continually monitoring all personnel and employment related activities to ensure that the EEO policy and the Contractor's obligations under these specifications are being carried out.
- n. Ensure that all facilities and company activities are non-segregated except that separate or single-user toilet and necessary changing facilities shall be provided to assure privacy between the sexes.

- o. Document and maintain a record of all solicitations of offers for subcontracts from minority and female construction contractors and suppliers, including a circulation of solicitations to minority and female contractor associations and other business associations.
  - p. Conduct a review, at least annually, of all supervisors' adherence to and performance under the Contractor's EEO policies and affirmative action obligations.
8. Contractors are encouraged to participate in voluntary associations which assist in fulfilling one or more of their affirmative action obligations (7a through 7p). The efforts of a contractor association, joint contractor union, contractor-community, or other similar group of which the Contractor is a member and participant, may be asserted a fulfilling any one or more of its obligations under 7a through p of these Specifications provided that the Contractor actively participates in the group, makes every effort to assure that the group has a positive impact on the group, makes every effort to assure that the group has a positive impact on the employment of minorities and women in the industry, ensures that the concrete benefits of the program are reflected in the Contractor's minority and female workforce participation, makes a good faith effort to meet its individual goals and timetables, and can provide access to documentation which demonstrates the effectiveness of actions taken on behalf of the Contractor. The obligation to comply, however, is the Contractor's and failure of such a group to fulfill an obligation shall not be a defense for the Contractor's noncompliance.
9. A single goal for minorities and a separate goal for women have been established. The Contractor, however, is required to provide equal opportunity and to take affirmative action for minority groups, both male and female, and all women, both minority and non- minority. Consequently, the Contractor may be in violation of the Executive Order if a particular group is employed in a substantially disparate manner (for example, even though the Contractor has achieved its goals for women generally, the Contractor may be in violation of the Executive Order if a specific minority group of women is underutilized).
10. The Contractor shall not use the goals and timetable or affirmative action standards to discriminate against any person because of race, color, religion, sex, or national origin.
11. The Contractor shall not enter into any subcontract with any person or firm debarred from Government contracts pursuant to Executive Order 11246.
12. The Contractor shall carry out sanctions and penalties for violation of these specifications and of the Equal Opportunity Clause, including suspension, termination and cancellation of existing subcontracts as may be imposed or ordered pursuant to Executive Order 11246, as amended, and its implementing regulations, by the Office of Federal Contract Compliance Programs. Any Contractor who fails to carry out such sanctions and penalties shall be in violation of these specifications and Executive Order 11246, as amended.
13. The Contractor, in fulfilling its obligations under these specifications, shall implement specific affirmative action steps, at least as extensive as those standards prescribed in paragraph 7 of these specifications, so as to achieve maximum results from its efforts to ensure equal employment opportunity. If the Contractor fails to comply with the requirements of the Executive Order, the implementing regulations, or these specifications, the Director shall proceed in accordance with 41 CFR 60-4.8.



14. The Contractor shall designate a responsible official to monitor all employment related activity to ensure that the company EEO policy is being carried out, to submit reports to the provisions hereof as may be required by the Government and to keep records. Records shall at least include for each employee the name, address, telephone numbers, construction trade, union affiliation if any, employee identification number when assigned, social security number, race, sex, status (e.g., mechanic, apprentice, trainee, helper, or laborer), dates of changes in status hours worked per week in the indicated trade, rate of pay, and locations at which the work was performed. Records shall be maintained in an easily understandable and retrievable form; however, to the degree that existing records satisfy this requirement, contractors shall not be required to maintain separate records.
15. Nothing herein provided shall be construed as a limitation upon the application to other laws establish different standards of compliance or upon the application or requirements for the hiring of local or other area residents (e.g., those under the Public Works Employment Act of 1977 and the Community Development Block Grant Program).

## **SECTION 3 CLAUSE**

### **24 CFR, Part 135.20 and Grant Agreement**

Every applicant, recipient, contracting party, contractor, and subcontractor shall incorporate, or cause to be incorporated, in all contracts for work in connection with a Section 3 covered project, the following clause (referred to as Section 3 clause):

- A. The work to be performed under this Contract is on a project assisted under a program providing direct Federal financial assistance from the Department of Housing and Urban Development and is subject to the requirements of Section 3 of the Housing and Urban Development Act of 1968, as amended, 12 U.S.C. 170 1u. Section 3 requires that to the greatest extent feasible opportunities for training and employment be given lower income residents of the project to be awarded to business concerns which are located in or owned in substantial part by persons residing in the area of the project.
- B. The parties to this Contract will comply with the provisions of said Section 3 and the regulations issued pursuant thereto by the Secretary of Housing and Urban Development set forth in 24 CFR, 135, and all applicable rules and orders of the Department issued thereunder prior to the execution of this Contract. The parties to this Contract certify and agree that they are under no contractual or other disability which would prevent them from complying with these requirements.
- C. The Contractor will send to each labor organization or representative of workers with which he has a collective bargaining agreement or other Contract or understanding, if any, a notice advising the said labor organization or worker's representative of his commitments under this Section 3 clause and shall post copies of the notice in conspicuous places available to employees and applicants for employment or training.
- D. The Contractor will include this Section 3 clause in every subcontract for work in connection with the project and will at the direction of the applicant for or recipient of Federal financial assistance, take appropriate action pursuant to the subcontract upon a finding that the subcontractor is in violation of regulations issued by the Secretary of Housing and Urban Development 24 CFR 135. The Contractor will not subcontract with any subcontractor where it has notice or knowledge that the latter has been found in violation of regulations under 24 CFR 135 and will not let any subcontract unless the subcontractor has first provided it with a preliminary statement of ability to comply with the requirements of these regulations.
- E. Compliance with the provisions of Section 3, the regulations set forth in 24 CFR 135, and all applicable rules and orders of the Department issued thereunder prior to the execution of the Contract, shall be a condition of the Federal financial assistance provided to the project, binding upon the applicant or recipient, its contractors and subcontractors, its successors, and assigns to those sanctions specified by the grant or loan agreement or contract through which Federal assistance is provided and to such sanctions as are specified by 24 CFR 135.

Note: Contractors are required to submit a Section 3 Affirmative Action Plan within 15 days of award of Contract. The Plan is to describe the Contractor's affirmative efforts to train and employ lower income residents of the project area and to subcontract work with small businesses in the project area.

## **\*SECTION 3 FINAL RULE**

### **24 CFR, Part 75**

Subject: Section 3 of the Housing and Urban Development Act of 1968, as amended by the Housing and Community Development Act of 1992, final rule requirements for CDBG, CDBG-CV, CDBG- DR, CDBG-MIT, NSP, Section 108, and RHP projects.

#### **I. PURPOSE**

This notice provides guidance to Community Development Block Grant (CDBG), Community Development Block Grant CARES Act (CDBG-CV), CDBG Disaster Recovery (CDBG-DR), CDBG Mitigation (CDBG-MIT), Neighborhood Stabilization Program (NSP), and Recovery Housing Program (RHP) grantees and Section 108 Loan Guarantee Program (Section 108) borrowers (collectively, “grantees”) on the requirements for Section 3 of the Housing and Urban Development Act of 1968, as amended by the Housing and Community Development Act of 1992 (Section 3). These requirements apply to CDBG, CDBG-CV, CDBG-DR, CDBG-MIT, NSP, Section 108, and RHP-assisted housing rehabilitation, housing construction and other public construction projects. This notice outlines the key changes made by the notice entitled, “Enhancing and Streamlining the Implementation of Section 3 Requirements for Creating Economic Opportunities for Low- and Very Low-Income Persons and Eligible Businesses,” (85 FR 61524) (“Final Rule”) published in the *Federal Register* on September 29, 2020 (codified at 24 CFR part 75) and provides guidance for tracking and reporting compliance with the new requirements. Refer to 24 CFR 75 for any further updates on Section 3 requirements after the publication of this notice.

#### **II. BACKGROUND**

Section 3 contributes to the establishment of stronger, more sustainable communities by ensuring that employment and other economic opportunities generated by Federal financial assistance for housing and community development programs are, to the greatest extent feasible and consistent with existing Federal, state, and local laws and regulations, directed toward low- and very low- income persons. Section 3 applies to training or employment arising in connection with HUD- funded housing rehabilitation, housing construction, or other public construction projects, and any contracting opportunities arising in connection with both public housing and other Section 3 projects. These opportunities are, to the greatest extent feasible, required to be given to low- and very low-income persons and business concerns that provide economic opportunities to low- or very low-income persons, particularly those who are recipients of government assistance for housing or residents of the community in which the Federal assistance is spent.

On September 29, 2020, HUD published the Final Rule and a companion notice, entitled “Section 3 Benchmarks for Creating Economic Opportunities for Low- and Very Low-Income Persons and Eligible Businesses,” (85 FR 60907) (“Benchmark Notice”), in the *Federal Register*. Prior to the publication of the Final Rule and Benchmark Notice, HUD operated under regulations (found at 24 CFR part 135) (“former regulation”) provided by the Section 3 interim rule, which HUD published in 1994.

The regulation, provided by the Section 3 Final Rule, became effective on November 30, 2020 and is codified at 24 CFR part 75. The regulation simplifies the Section 3 requirements and establishes that Section 3 requirements apply to housing rehabilitation, housing construction, and other public construction projects assisted under HUD programs that provide housing and community development financial assistance when the total amount of assistance to the project exceeds a minimum funding threshold. The regulation also improves alignment with current business practices

by requiring the reporting of labor hours rather than new hires. Additionally, the regulation streamlines the reporting process and establishes HUD program office oversight to reduce administrative burden and make the rule more effective. The Benchmark Notice establishes the current numeric goals for compliance with Section 3 requirements. Pursuant to the regulation at 24 CFR 75.23(b)(1) and (b)(2), HUD may adjust funding thresholds or establish new benchmarks (either a single nationwide benchmark or multiple benchmarks based on geography, type of assistance, or other variables) periodically as new information becomes available. HUD must publish all updates in the *Federal Register* and all updates are subject to public comment.

### III. APPLICABILITY

#### A. FUNDING THRESHOLD

The regulation established an applicability threshold of **\$200,000** for housing rehabilitation, housing construction, and other public construction (e.g., public facilities and improvements) projects assisted with housing and community development financial assistance. Housing and community development financial assistance includes, but is not limited to, CDBG, CDBG-DR, CDBG-MIT, NSP, Section 108, RHP, HOME Investment Partnership (HOME), Housing Trust Fund (HTF), Emergency Solutions Grants (ESG), Housing Opportunities for Persons with AIDS (HOPWA), Section 202 Direct Loan Program for Housing for the Elderly, Section 811 Supportive Housing for Persons with Disabilities, Lead Abatement Grants, and other HUD Notice of Funding Opportunities (NOFO) grants.

**Per 24 CFR 75.3, the Section 3 requirements apply based on the amount of housing and community development funding provided by one or a combination of two or more different applicable HUD programs exceeding the \$200,000 threshold.** For example, if a project is funded with \$101,000 of HOME funds and \$100,000 of CDBG funds, then it exceeds the applicability threshold of \$200,000 and the Section 3 requirements apply.

**Per 24 CFR 75.3(a)(iii), Section 3 requirements apply to the entire project, not just the HUD-financed portion.** If a housing rehabilitation, housing construction, or other public construction project receives more than \$200,000 of HUD funding, then Section 3 requirements are triggered and apply to all employment and training opportunities and contracts for work arising in connection with the project (subject to section III.B. below), including efforts that are financed by other, non-HUD sources of funds. Grantees must make all recipients, contractors, and subcontractors aware of the need to comply with Section 3 requirements.

**The Section 3 requirements also apply when a project receives less than \$200,000 in HUD housing and community development financial assistance but receives public housing financial assistance, as defined in 24 CFR 75.3(a)(1), or more than \$100,000 of Lead Hazard Control and Healthy Homes program funding, as defined in 24 CFR 75.3(a)(2)(i).** For example, if a project is funded with \$75,000 of CDBG funds and \$10,000 of public housing financial assistance funds, then Section 3 requirements apply because public housing financial assistance is provided. See 24 CFR part 75 Subpart D for requirements that apply to projects with multiple funding sources. Also see Section V.B. below.

#### B. PROJECT AND ACTIVITY TYPES

Section 3 requirements apply to a housing rehabilitation, housing construction or other public construction project no matter which portion of the project receives the CDBG, CDBG-CV, CDBG-DR,

CDBG-MIT, NSP, Section 108 guaranteed loan funds, or RHP financial assistance. The project is the site or sites together with any building(s) and improvements located on the site(s) that are under common ownership, management, and financing (e.g., CDBG funds used to rehabilitate 20 units in one building as part of an effort to rehabilitate 40 units in two buildings on a single property. The “Section 3 project” includes the rehabilitation of all 40 units.).

Once the project is complete, the Section 3 requirements no longer apply to subsequent contracts.

Section 3 requirements do not apply to projects assisted with housing and community development financial assistance that do not include housing rehabilitation, housing construction or other public construction (e.g., funds used for direct homebuyer assistance or tenant-based rental assistance). Pursuant to 24 CFR 75.3(b), Section 3 requirements also do not apply to materials-only contracts or contracts that do not require any labor. For example, Section 3 would not apply to contracts for office or janitorial supplies because these are materials-only contracts.

CDBG, Section 108, and CDBG-CV grantees must report Section 3 data in HUD’s Integrated Disbursement and Information System (IDIS). CDBG-DR, CDBG-MIT, NSP, and RHP grantees must report Section 3 data in HUD’s Disaster Recovery Grant Reporting (DRGR) system. Grantees are cautioned to not include multiple Section 3 projects under a single activity in IDIS or DRGR; this would cause a distortion in the calculation of the benchmarks, particularly if the benchmarks were not met for one of the included projects. Instead, to properly report Section 3 projects in IDIS or DRGR, each project must be established as a distinct activity. CDBG regulations use the term “activity” which is the same as “project” for the purposes of this notice.

#### **IV. LABOR HOURS**

The regulation introduces several new concepts and definitions to align the regulations more closely with the statutory priorities for hiring and contracting and with grantee current practices. The most significant change is the switch from tracking and reporting new hires and contracts to tracking and reporting labor hours. “Labor hours” means the number of paid hours worked by persons on a Section 3 project or by persons employed with funds that include public housing financial assistance (24 CFR 75.5). The Final Rule’s focus on labor hours seeks to measure total actual employment and the proportion of the total employment performed by low- and very low- income workers. In addition, the change to tracking labor hours captures continued and long- term employment. The focus on labor hours creates an incentive for employers to invest in and retain their newly hired workers. 24 CFR 75.25 requires grantees to report the total labor hours for three categories of workers on the project: all workers, Section 3 workers, and Targeted Section 3 workers. The definitions in 24 CFR 75.5 for a “Section 3 worker,” “Targeted Section 3 worker,” and “Section 3 business concern” simplify grantee reporting and better align with statutory priorities. Benchmarks that apply to each of these categories of workers will serve as safe harbors for compliance, as discussed in Section VI of this notice.

Pursuant to 24 CFR 75.27, grantees must include language applying Section 3 requirements in any agreement or contract for a Section 3 project and must require contractors and subcontractors to meet the regulation’s requirements, regardless of whether their agreements or contracts include Section 3 language.

##### **A. SECTION 3 WORKER (*please see “Required Certification” section for certification forms*)**

The new definition of Section 3 worker, at 24 CFR 75.5, implements the statutory requirement that grantees ensure that job and contracting opportunities arising in connection with a HUD- funded housing rehabilitation, housing construction, or other public construction project are provided to

Section 3 workers or Section 3 business concerns to the greatest extent feasible. In accordance with the regulation, a Section 3 worker is a worker who currently fits or when hired within the past five years fits at least one of the following categories:

1. Is a low- or very low-income worker that fell below HUD income limits for the previous or annualized calendar year. Low- and very-low-household income limits may be obtained from: [Income Limits | HUD USER](#)
2. Is employed by a Section 3 business concern (defined in Section C).
3. Is a YouthBuild participant. YouthBuild is a community-based pre-apprenticeship program administered by the U.S. Department of Labor that provides job training and educational opportunities for at-risk youth ages 16-24 who have previously dropped out of high school.

Grantees may count Section 3 workers' labor hours for five years from when their status as a Section 3 worker is established, pursuant to 24 CFR 75.31. For purposes of reporting the labor hours for Section 3 workers, an employer may choose whether to define the workers as Section 3 workers for a five-year period at the time of the workers' hire, or when the workers are first certified as meeting the Section 3 worker definition. The five-year period for a worker cannot begin before November 30, 2020; therefore, Section 3 workers hired prior to November 30, 2020, may be certified for a five-year period beginning November 30, 2020.

Pursuant to 24 CFR 75.5, a prior arrest or conviction cannot negatively affect the status of a Section 3 worker. Furthermore, Section 3 workers are not exempt from meeting position qualification requirements nor do the regulations require the employment of an individual meeting the definition of a Section 3 worker.

A worker may qualify as a Section 3 worker through one of the following certifications, in accordance with 24 CFR 75.31:

1. A worker's self-certification that their income is below HUD's income limit from the prior calendar year.
2. A worker's self-certification of participation in a means-tested program such as public housing or Section 8-assisted housing.
3. Certification from a public housing authority (PHA), or an owner or property manager of project-based Section 8-assisted housing, or an administrator of tenant-based Section 8-assisted housing that the worker is a participant in one of their programs.
4. An employer's certification that a worker's income from that employer is below HUD's income limit when based on an employer's calculation of what the worker's wage rate would translate to if annualized on a full-time basis.
5. An employer's certification that the worker is employed by a Section 3 business concern.

Pursuant to 24 CFR 75.31, for a worker to qualify as a Section 3 worker, the grantee must maintain (or ensure that the subrecipient, contractor, or subcontractor that employs the worker maintains) one of the listed records above from the time the worker is certified as meeting the Section 3 worker definition for the five-year period or from the time of hire (if hired within the last five years). Pursuant to 24 CFR 75.31(c), the documentation described above must be maintained for the time period required for record retention in accordance with applicable program regulations or, in the absence of applicable program regulations, in accordance with 2 CFR part 200.

## **LABOR STANDARDS**

### **Davis-Bacon Act (DBA)**

The Davis-Bacon Act requires the payment of prevailing wage rates (which are determined by the U.S. Department of Labor) to all laborers and mechanics on Federal government and District of Columbia construction projects in excess of \$2,000. Construction includes alteration and/or repair, including painting and decorating, of public buildings or public works.

### **Contract Work Hours and Safety Standards Act (CWHSSA)**

CWHSSA requires time and one-half pay for overtime (O/T) hours (over 40 in any workweek) worked on the covered project. The CWHSSA applies to both direct Federal contracts and to indirect Federally-assisted contracts except where the assistance is solely in the nature of a loan guarantee or insurance. CWHSSA violations carry a liquidated damages penalty (\$10/day per violation). Intentional violations of CWHSSA standards can be considered for Federal criminal prosecution.

Where applicable, all contracts awarded by grantees and subgrantees in excess of \$2,000.00 for construction contracts and in excess of \$2,500.00 for other contracts which involve the employment of mechanics or laborers shall include a provision for compliance with Sections 103 and 107 of the Contract Work Hours and Safety Standards Act (40 U.S.C. 327-330) as supplemented by the Department of Labor regulations (29 CFR, Part 5). Under Section 103 of the Act, each contractor shall be required to compute the wages of every mechanic and laborer on the basis of a standard work- day of eight (8) hours and a standard work week of forty (40) hours. Work in excess of the standard work day or work week is permissible provided that the worker is compensated at a rate of not less than one and one-half (1-1/2) times the basic rate of pay for all hours worked in excess of eight (8) hours in any calendar day or forty (40) hours in the work week. Section 107 of the Act is applicable to construction work and provides that no laborer or mechanic shall be required to work in surroundings or under working conditions which are unsanitary, hazardous, or dangerous to his health and safety as determined under construction, safety and health standards promulgated by the Secretary of labor. These requirements do not apply to the purchases of supplies or materials or articles ordinarily available on the open market, or contracts for transportation or transmission of intelligence.

### **Contract Work Hours and Safety Standards Act (CWHSSA) Coverage threshold for overtime and health and safety provisions.**

The *Federal Acquisition Streamlining Act of 1994* amends sections 103 and 107 of the Contract Work Hours and Safety Standards Act (CWHSSA) to establish a single threshold excluding single contracts of \$100,000 or less from CWHSSA overtime and health and safety provisions. (Previously, CWHSSA overtime thresholds were \$2,000 for construction work and \$2,500 for Federal purchases and contracts other than construction.) The new threshold became effective October 1, 1995.

For contracting agencies, the effect of the threshold increase will primarily result in reduced procurement burdens on purchases of \$100,000 or less. Contractors will continue to be obligated to pay weekly overtime under the Fair Labor Standards Act (FLSA).

Other changes involve overtime provision enforcement activities. FLSA enforcement authority resides solely with the Department of Labor (DOL). Complaints and violations relative to FLSA overtime compensation must be

referred to the DOL for further review and disposition. HUD staff and program clients (PHAs/IHAs, CDBG grantees) are still responsible for ensuring contractor compliance with prevailing wage requirements. Where the complaints or violations involve both FLSA overtime and prevailing wages, early consultation with the DOL should occur to determine the most appropriate means to pursue both aspects to resolution.

Proposed language to conform applicable regulations to the statutory amendments was published by the DOL on September 7, 1995. (See *Federal Register*, Vol. 60, No. 173, Pgs 46553-46556.)

#### **Copeland Act (Anti-Kickback Act)**

The Copeland Act makes it a Federal crime for anyone to require any laborer or mechanic (employed on a Federal or Federally-assisted project) to kickback (i.e., give up or pay back) any part of their wages. The Copeland Act requires every employer (contractors and subcontractors) to submit weekly certified payroll reports (CPR's) and regulates permissible payroll deductions.

#### **Fair Labor Standards Act (FLSA)**

The Fair Labor Standards Act (FLSA) contains Federal minimum wage rates, overtime (O/T), and child labor requirements. These requirements generally apply to any labor performed. The Department of Labor (DOL) has the authority to administer and enforce FLSA. HUD will refer to the DOL any possible FLSA violations that are found on HUD projects.

#### **OTHER PROVISIONS AND REQUIRED PERFORMANCE**

##### **Clean Air Act of 1970 and The Federal Water Pollution Control Provision**

Contracts and subgrants of amounts in excess of \$100,000.00 shall contain a provision which requires the recipient to agree to comply with all applicable standards, orders, or regulations issued pursuant to the Clean Air Act of 1970 ( 42 U.S.C. 1857 et seq. ) and the Federal Water Pollution Control Act ( 33 U.S.C. 1251 et seq. ) as amended. Violations shall be reported to the grantor agency and the Regional Office of the Environmental Protection Agency.

##### **Architectural Barriers Act of 1968 Provision**

All contracts for construction of facilities shall contain a provision which requires the recipient to comply with the Architectural Barriers Act of 1968 ( 42 U.S.C. 4151 ) requirement that the design of any facility constructed comply with the "American Standard Specification for Making Buildings and Facilities Accessible and Usable by the Physically Handicapped," Number A-117.1 – 1961, as modified.

##### **Record Keeping and Inspections (Required Performance)**

During the performance of this Contract, the Contractor agrees that the municipality, the Federal Grantor Agency, the Comptroller General of the United States, or any of their duly authorized representatives shall have access to books, documents, papers, and records of the Contractor which are directly pertinent to a specific grant program for the propose of making an audit, examination, excerpts, and transcriptions.



**STANDARDS ADMINISTRATION DEPARTMENT OF LABOR EMPLOYMENT  
MINIMUM WAGES FOR FEDERAL AND FEDERALLY ASSISTED CONSTRUCTION  
PROJECTS OVER \$2,000.00**

**General Wage Determination Decisions**

General Wage Determination Decisions of the Secretary of Labor Specify in accordance with applicable law and on the basis of information available to the Department of Labor from its study of local wage conditions and from other sources, the basic hourly wage rates and fringe benefit payment which are determined to be prevailing for the described classes of laborers and mechanics employed in construction activity of the character and in the localities specified therein.

The determinations in these decisions of such prevailing rates and fringe benefits have been made by authority of the Secretary of Labor pursuant to the provisions of the Davis-Bacon Act of March 3, 1931, as amended (46 Stat. 1494, as amended, 40 U.S.C. 276a) and of other Federal statutes referred to in 29 CFR 1.1 (including the statutes listed at 36 FR 306 following Secretary of Labor's Order No. 24-70) containing provisions for the payment of wages which are dependent upon determination by the Secretary of Labor under the Davis-Bacon Act; and pursuant to the provisions of Part 1 of Subtitle A of Title 29 of Code of Federal Regulations,

Procedure for Predetermination of Wage Rates, (37 FR 21138) and of Secretary of Labor's Order's, 12-71 and 15-71 (36 FR 8755, 8756). The prevailing rates and fringe benefits determined in these decisions shall, in accordance with the provisions of the foregoing statutes, constitute the minimum wages payable on Federal and federally assisted construction projects to laborers and mechanics of the specified classes engaged in contract work of the character and in the localities described therein.

Good cause is hereby found for not utilizing notice and public procedure thereon prior to the issuance of these determinations as prescribed in 5 U.S. C. 553 and not providing for delay in effective date as prescribed in that section, because the necessity to issue construction industry wage determination frequently and in large volume causes procedures to be impractical and contrary to the public interest.

General Wage Determination Decisions are effective from their date of publication in the **FEDERAL REGISTER** without limitation as to time and are to be used in accordance with the provisions of 29 CFR Parts 1 and 5. Accordingly, the applicable decision, together with any modifications issued subsequent to its publication date shall be made a part of every contract for performance of the described work within the geographic area indicated as required by an applicable Federal prevailing wage law and 29 CFR Part 5. The wage rates contained therein shall be the minimum paid under such contract by contractors and subcontractors on the work.

**Modifications & Supersedes to General Wage Determination Decisions**

Modifications and Supersedes Decisions to General Wage Determination Decisions are based upon information obtained concerning changes in prevailing hourly wage rates and fringe benefit payment since the decisions were issued.

The determinations of prevailing rates and fringe benefits made in the Modifications and Supersedes Decisions have been made by authority of the Secretary of Labor pursuant to the provisions of the Davis-Bacon Act of March 3, 1931, as amended (46 Stat. 1494, as amended, 40 U.S.C. 276a) and of other Federal

statutes referred to in 29 CFR 1.1 (including the statutes listed at 36 FR 306 following Secretary of Labor's Order No. 24-70) containing provisions for the payment of wages which are dependent upon determination by the Secretary of Labor under the Davis-Bacon Act; and pursuant to the provisions of Part 1 of Subtitle A of Title 29 of Code of Federal Regulations, Procedure for Predetermination of Wage Rates, (37 FR 21138) and of Secretary of Labor's Order 13-71 and 15-71 (36 FR 8755, 8756). The prevailing rates and fringe benefits determined in foregoing General Wage Determination Decisions, as hereby modified, and/or superseded, shall, in accordance with the provisions of the foregoing statutes, constitute the minimum wages payable on Federal and federally assisted construction projects to laborers and mechanics of the specified classes engaged in contract work of the character and in the localities described therein.

Modification and Supersedes Decisions are effective from their date of publication in the **FEDERAL REGISTER** without limitation as to time and are to be used in accordance with the provisions of 29 CFR Parts 1 and 5.

Any person, organization, or governmental agency having an interest in the wages determined, as prevailing is encouraged to submit wage rate information for consideration by the Department. Further information and self-explanatory forms for the purpose of submitting this data may be obtained by writing to the U.S. Department of Labor, Employment Standards Administration, Office of Special Wage Determinations, Washington, D.C. 20210. The cause for not utilizing the rule-making procedures prescribed in 5 U.S.C. 553 has been set forth in the original General Wage Determination Decision.

#### **New General Wage Determination Decisions**

The most recent Federal General Wage Determination Decision for Illinois date is 02/23/24, which is attached and made part of this special provision.

"General Decision Number: IL20240009 02/23/2024

Superseded General Decision Number: IL20230009

State: Illinois

Construction Types: Building, Heavy, Highway and Residential

County: Cook County in Illinois.

BUILDING, RESIDENTIAL, HEAVY, AND HIGHWAY PROJECTS (does not include landscape projects).

Note: Contracts subject to the Davis-Bacon Act are generally required to pay at least the applicable minimum wage rate required under Executive Order 14026 or Executive Order 13658. Please note that these Executive Orders apply to covered contracts entered into by the federal government that are subject to the Davis-Bacon Act itself, but do not apply to contracts subject only to the Davis-Bacon Related Acts, including those set forth at 29 CFR 5.1(a)(1).

<p>If the contract is entered into on or after January 30, 2022, or the contract is renewed or extended (e.g., an option is exercised) on or after January 30, 2022:</p>	<ul style="list-style-type: none"> <li>. Executive Order 14026 generally applies to the contract.</li> <li>. The contractor must pay all covered workers at least \$17.20 per hour (or the applicable wage rate listed on this wage determination, if it is higher) for all hours spent performing on the contract in 2024.</li> </ul>
<p>If the contract was awarded on or between January 1, 2015 and January 29, 2022, and the contract is not renewed or extended on or after January 30, 2022:</p>	<ul style="list-style-type: none"> <li>. Executive Order 13658 generally applies to the contract.</li> <li>. The contractor must pay all covered workers at least \$12.90 per hour (or the applicable wage rate listed on this wage determination, if it is higher) for all hours spent performing on that contract in 2024.</li> </ul>

The applicable Executive Order minimum wage rate will be adjusted annually. If this contract is covered by one of the Executive Orders and a classification considered necessary for performance of work on the contract does not appear on this wage determination, the contractor must still submit a conformance request.

Additional information on contractor requirements and worker protections under the Executive Orders is available at <http://www.dol.gov/whd/govcontracts>.

Modification Number      Publication Date  
0                              01/05/2024

1	02/09/2024
2	02/23/2024

ASBE0017-001 06/01/2021

	Rates	Fringes
ASBESTOS WORKER/INSULATOR		
Includes the application of all insulating materials, protective coverings, coatings, and finishes to all types of mechanical systems.....		
	\$ 51.80	30.60
Fire Stop Technician.....	\$ 41.44	27.85
HAZARDOUS MATERIAL HANDLER		
includes preparation, wetting, stripping removal scrapping, vacuuming, bagging and disposal of all insulation materials, whether they contain asbestos or not, from mechanical systems.....		
	\$ 38.85	27.85

-----  
BOIL0001-001 05/01/2021

	Rates	Fringes
BOILERMAKER.....	\$ 52.61	33.07

-----  
BRIL0021-001 06/01/2016

	Rates	Fringes
BRICKLAYER.....	\$ 44.88	26.62

-----  
BRIL0021-004 06/01/2017

	Rates	Fringes
Marble Mason.....	\$ 44.63	26.83

-----  
BRIL0021-006 06/01/2017

	Rates	Fringes
TERRAZZO WORKER/SETTER.....	\$ 44.38	25.84
TILE FINISHER.....	\$ 38.56	22.10
TILE SETTER.....	\$ 45.49	25.72

-----  
BRIL0021-009 06/01/2017

	Rates	Fringes
MARBLE FINISHER.....	\$ 33.95	26.03

-----  
BRIL0021-012 06/01/2017

	Rates	Fringes
Pointer, cleaner and caulker.....	\$ 45.42	24.06

-----  
CARP0555-001 06/01/2022

BUILDING, HEAVY, AND HIGHWAY

Rates Fringes

CARPENTER

Carpenter, Lather,  
Millwright, Piledriver,  
and Soft Floor Layer

Building.....	\$ 52.01	38.85
Heavy & Highway.....	\$ 52.01	38.85

-----  
CARP0555-002 10/01/2023

RESIDENTIAL CONSTRUCTION

Rates Fringes

CARPENTER.....	\$ 45.61	35.31
----------------	----------	-------

-----  
ELEC0009-003 05/28/2023

Rates Fringes

Line Construction		
Groundman.....	\$ 46.92	60.91%
Lineman and Equipment		
Operator.....	\$ 60.15	60.91%

-----  
ELEC0134-001 06/06/2022

Rates Fringes

ELECTRICIAN.....	\$ 52.05	39.12
------------------	----------	-------

-----  
ELEC0134-003 06/05/2023

Rates Fringes

ELECTRICIAN		
ELECTRICAL TECHNICIAN.....	\$ 48.66	30.86

The work shall consist of the installation, operation, inspection, maintenance, repair and service of radio, television, recording, voice sound vision production and reproduction, telephone and telephone interconnect, facsimile, data apparatus, coaxial, fibre optic and wireless equipment, appliances and systems used for the transmission and reception of signals of any nature, business, domestic, commercial, education, entertainment and residential purposes, including but not limited to communication and telephone, electronic and sound equipment, fibre optic and data communication systems, and the performance of any task directly related to such installation or service whether at new or existing sites, such tasks to include the placing of wire and cable and electrical power conduit or other raceway work within the equipment room and pulling wire and/or cable through conduit and the installation of any incidental conduit.

-----  
\* ELEV0002-001 01/01/2024

Rates Fringes

ELEVATOR MECHANIC.....	\$ 67.84	37.885+a+b
------------------------	----------	------------

FOOTNOTES:

a) PAID HOLIDAYS: New Year's Day; Memorial Day; Independence Day; Labor Day; Thanksgiving Day; Day after Thanksgiving Day; Veterans' Day and Christmas Day.

b) Employer contributes 8% of regular hourly rate as vacation pay credit for employee with more than 5 years of service, and 6% for employee with less than 5 years service

-----  
 \* ENGI0150-006 06/01/2023

Building and Residential Construction

	Rates	Fringes
OPERATOR: Power Equipment		
GROUP 1.....	\$ 56.60	47.70
GROUP 2.....	\$ 55.30	47.70
GROUP 3.....	\$ 52.75	47.70
GROUP 4.....	\$ 51.00	47.70

POWER EQUIPMENT OPERATORS CLASSIFICATIONS

GROUP 1: Mechanic; Asphalt Plant\*; Asphalt Spreader; Autograde\*; Backhoes with Caisson attachment\*;Batch Plant\*; Benoto(Requires two Engineers); Boiler and Throttle Valve; Caisson Rigs\*; Central Redi-Mix Plant\*; Combination Backhoe Front Endloader Machine; Compressor and Throttle Valve; Concrete Breaker (Truck Mounted)\*; Concrete Conveyor; Concrete Conveyor, Truck Mounted; Concrete Paver over 27E cu. ft.\*; Concrete Paver 27E cu ft and Under\*; Concrete Placer\*; Concrete Placing Boom; Concrete Pump (Truck Mounted); Concrete Tower; Cranes\*; Cranes, Hammerhead\*; Cranes, (GCI and similar type Requires two operators only); Creter Crane; Crusher, Stone, etc; Derricks; Derricks, Traveling\*; Formless Curb and Gutter Machine\*; Grader, Elevating; Grouting Machines; Highlift Shovels or Front Endloader 2 1/4 yd. and over; Hoists, Elevators, Outside Type Rack and pinion and similar Machines; Hoists, One, Two, and Three Drum; Hoists, Two Tugger One Floor; Hydraulic Backhoes\*; Hydraulic Boom Trucks; Hydraulic Vac (and similar equipment);Locomotives; Motor Patrol\*; Pile Drivers amd Skid Rig\*; Post Hole Digger; Pre- Stress Machine; Pump Cretes Dual Ram(Requiring frequent Lubrication and Water); Pump Cretes; Squeeze Cretes-Screw Type Pumps Gypsum Bulker and Pump; Raised and Blind Hole Drill\*; Roto Mill Grinder (36"" and Over)\*; Roto Mill Grinder (Less Than 36"")\*; Scoops-Tractor Drawn; Slip-Form Paver\*; Straddle Buggies; Tournapull; Tractor with Boom, and Side Boom; and Trenching Machines\*.

GROUP 2: Bobcat (over 3/4 cu yd); Boilers; Broom, Power Propelled; Bulldozers; Concrete Mixer (Two Bag and over); Conveyor, Portable; Forklift Trucks; Greaser Engineer; Highlift Shovels or Front End loaders under 2 1/4 cu yd; Aotomatic Hoists, Hoists, Inside Elevators; Hoists, Sewer Dragging Machine; Hoists, Tugger Single Drum; Laser Screed; Rock Drill (Self-Propelled); Rock Drill (Truck Mounted)\*; Rollers; Steam Generators; Tractors; Tractor Drawn Vibratory Roller (Receives an additional \$.50 per hour); Winch Trucks with ""A"" Frame.

GROUP 3: Air Compressor-Small 250 and Under (1 to 5 not to exceed a total of 300 ft); Air Compressor-Large over 250; Combination-Small Equipment Operator; Generator- Small 50 kw and under; Generator-Large over 50 kw; Heaters, Mechanical; Hoists, Inside Elevators (Remodeling or Renovatin work); Hydrualic Power Units (Pile Driving, Extracting, and Drilling); Low Boys; Pumps Over 3"" (1 To 3 not to exceed a total of 300 ft); Pumps, Well Points; Welding Machines (2 through 5); Winches, 4 Small Electric Drill Winches; Bobcat (up to and including 3/4 cu yd)

GROUP 4 - Bobcats and/or other Skid Steer Loaders; Brick Forklifts; Oilers

\*-Requires Oiler

-----  
 \* ENGI0150-025 06/01/2023

Heavy and Highway Construction

	Rates	Fringes
OPERATOR: Power Equipment		
GROUP 1.....	\$ 54.80	47.70
GROUP 2.....	\$ 54.25	47.70
GROUP 3.....	\$ 52.20	47.70
GROUP 4.....	\$ 50.80	47.70
GROUP 5.....	\$ 49.60	47.70

POWER EQUIPMENT OPERATOR CLASSIFICATIONS

GROUP 1: Asphalt Plant\*; Asphalt Heater and Planer combination; Asphalt Heater Scarfire\*, Asphalt Spreader; Autograder/ GOMACO or similar; ABG Paver\*, Backhoes with Caisson attachment\*, Ballast Regulator, Belt Loader\*; Caisson Rigs\*Car Dumper, Central Redi-Mix Plant\*, Combination Backhoe; Front End Loader Machine (1 cu yd or over Backhoe bucket or with attachments); Concrete Breaker (truck mounted); Concrete Conveyor; Concrete Paver over 27E cu ft\*; Concrete Placer\*; Concrete Tube Float; Cranes, all attachments\*; Cranes, Hammerhead, Linden, Peco and machines of a like nature\*; Creter Crane; Crusher, stone; All Derricks; Derrick Boats; Derricks, traveling\*; Dowell Machine with Air Compressor (\$1.00 above Class 1); Dredges\*; Field Mechanic Welder; Formless Curb and Gutter Machine\*; Gradall and machines of a like nature\*; Grader, Elevating; Grader, Motor Grader, Motor Patrol, Auto Patrol, Form Grader, Pull Grader, Subgrader; Guard Rail Post Driver mounted\*; Hoists, one, two, and three Drum; Hydraulic Backhoes\*; Backhoes with Shear attachments\*; Mucking Machine; Pile Drivers and Skid Rig\*; Pre-Stress Machine; Pump Cretes Dual Ram (requires frequent lubrication and water)\*; Rock Drill- Crawler or Skid Rig\*; Rock Drill truck mounted\*; Rock/ Track Tamper; Roto Mill Grinder, (36"" and over)\*; Slip-Form Paver\*; Soil Test Drill Rig, truck mounted\*; Straddle Buggies; Hydraulic Telescoping Form (tunnel); Tractor Drawn Belt Loader\*; Tractor Drawn Belt Loader with attached Pusher (two engineers); Tractor with boom; Tractaire with attachment; Traffic Barrier Transfer Machine\*; Trenching Machine; Truck Mounted Concrete Pump with boom\*; Underground Boring and/or Mining Machines 5 ft in diameter and over tunnel, etc.\*; Wheel Excavator\* & Widener (Apsco); Raised or Blind Hoe Drill, Tunnel & Shaft\*

GROUP 2: Batch Plant\*; Bituminous Mixer; Boiler and Throttle Valve; Bulldozer; Car Loader Trailing Conveyors; Combination Backhoe Front End Loader Machine, (less than 1 cu yd Backhoe Bucket with attachments); Compressor and Throttle Valve; Compressor, common receiver (3); Concrete Breaker or Hydro Hammer; Concrete Grinding Machine; Concrete Mixer or Paver 7S series to and including 27 cu ft; Concrete Spreader; Concrete Curing Machine; Burlap Machine; Belting Machine and Sealing Machine; Concrete Wheel Saw; Conveyor Muck Cars (Haglund or similar type); Drills (all); Finishing Machine-Concrete; Greaser Engineer; Highlift Shovels or Front End Loader; Hoist- Sewer Dragging Machine; Hydraulic Boom Trucks, all attachments; Hydro-Blaster (requires two operators); Laser Screed\*; Locomotives, Dinky; Off-Road Hauling Units (including articulating); Pump Cretes; Squeeze Cretes-Screw Type pumps, Gypsum Bulker and Pump; Roller Asphalt; Rotary Snow Plows; Rototiller, Seaman, self-Propelled; Scoops-Tractor Drawn; Self- propelled Compactor; Spreader-Chip-Stone; Scraper; Scraper-Prime Mover in Tandem regardless of size (add \$1.00 to Group 2 hourly rate for each hour and for each machine attached thereto add \$1.00 to Group 2 hourly rate for each hour); Tank Car Heater; Tractors, Push, pulling Sheeps Foot, Disc, or Compactor, etc; Tug Boats

GROUP 3: Boilers; Brooms, all power propelled; Cement Supply Tender; Compressor, Common Receiver (2); Concrete Mixer, two bag and over; Conveyor, Portable; Farm type Tractors used for mowing, seeding, etc; Fireman on Boilers; Forklift Trucks; Grouting Machines; Hoists, Automatic; Hoists, all Elevators; Hoists, Tugger single Drum; Jeep Diggers; Low Boys; Pipe Jacking Machines; Post-hole Digger; Power Saw, Concrete, Power Driven; Pug Mills; Rollers, other than asphalt; Seed and Straw Blower; Steam Generators; Stump Machine; Winch Trucks with A-Frame; Work Boats; Tamper-Form motor driven

GROUP 4: Air compressor - Small 250 and under (1 to 5 not to exceed a total of 300 ft); Air Compressor - Large over 250; Combination - Small Equipment Operator; Directional Boring Machine; Generators - Small 50 kw and under; Generators - Large , over 50 kw; Heaters, Mechanical; Hydraulic power unit (Pile Driving, Extracting or Drilling); Light Plants (1 to 5); Pumps, over 3" (1 to 3, not to exceed a total of 300 ft); Pumps, Well Points; Tractaire; Welding Machines (2 through 5); Winches, 4 small electric drill winches;

GROUP 5: Bobcats (All); Brick Forklifts; Oilers; Directional Boring

\*Requires Oiler

-----  
IRON001-026 06/01/2023

	Rates	Fringes
IRONWORKER		
Sheeter.....	\$ 57.25	43.75
Structural and Reinforcing..	\$ 57.00	43.75

-----  
IRON0063-001 06/01/2023

	Rates	Fringes
--	-------	---------



IRONWORKER, ORNAMENTAL.....\$ 55.01 42.23  
-----

IRON0063-002 06/01/2023

Rates Fringes

IRONWORKER  
Fence Erector.....\$ 48.48 32.75  
-----

IRON0136-001 07/01/2023

Rates Fringes

IRONWORKER  
Machinery Movers; Riggers;  
Machinery Erectors.....\$ 48.00 42.69  
Master Riggers.....\$ 50.50 42.69  
-----

LAB00002-006 06/01/2022

Rates Fringes

LABORER (BUILDING &  
RESIDENTIAL)  
GROUP 1.....\$ 47.40 33.16  
GROUP 2.....\$ 47.40 33.16  
GROUP 3.....\$ 47.48 33.16  
GROUP 4.....\$ 47.50 33.16  
GROUP 5.....\$ 47.55 33.16  
GROUP 6.....\$ 47.60 33.16  
GROUP 7.....\$ 47.63 33.16  
GROUP 8.....\$ 47.73 33.16  
GROUP 9.....\$ 47.75 33.16  
GROUP 10.....\$ 47.85 33.16  
GROUP 11.....\$ 47.68 33.16  
GROUP 12.....\$ 48.40 33.16

LABORER CLASSIFICATIONS

GROUP 1: Building Laborers; Plasterer Tenders; Pumps for Dewatering; and other unclassified laborers.

GROUP 2: Fireproofing and Fire Shop laborers.

GROUP 3: Cement Gun.

GROUP 4: Chimney over 40 ft.; Scaffold Laborers.

GROUP 5: Cement Gun Nozzle Laborers (Gunite); Windlass and capstan person.

GROUP 6: Stone Derrickmen & Handlers.

GROUP 7: Jackhammermen; Power driven concrete saws; and other power tools.

GROUP 8: Firebrick & Boiler Laborers.

GROUP 9: Chimney on fire brick; Caisson diggers; & Well Point System men.

GROUP 10: Boiler Setter Plastic Laborers.

GROUP 11: Jackhammermen on fire brick work only.

GROUP 12: Dosimeter use (any device) monitoring nuclear exposure); Asbestos Abatement Laborer; Toxic and Hazardous Waste Removal Laborers.

-----  
LAB0002-007 06/01/2022

	Rates	Fringes
LABORER (HEAVY & HIGHWAY)		
GROUP 1.....	\$ 47.40	33.16
GROUP 2.....	\$ 47.48	33.16
GROUP 3.....	\$ 47.55	33.16
GROUP 4.....	\$ 47.68	33.16
GROUP 5.....	\$ 47.40	33.16

LABORER CLASSIFICATIONS

GROUP 1: Common laborer; Tenders; Material expeditor (asphalt plant); Street paving, Grade separation, sidewalk, curb & gutter, strippers & All laborers not otherwise mentioned

GROUP 2: Asphalt tampers & smoothers; Cement gun laborers

GROUP 3: Cement Gun Nozzle (laborers), Gunite

GROUP 4: Rakers, Lutemen; Machine-Screwmen; Kettlemen; Mixermen; Drun-men; Jackhammermen (asphalt); Paintmen; Mitre box spreaders; Laborers on birch, overman and similar spreader equipment; Laborers on APSCO; Laborers on air compressor; Paving Form Setter; Jackhammermen (concrete); Power drive concrete saws; other power tools.

GROUP 5: Asbestos Abatement Laborers; Toxic and Hazardous Waste Removal Laborers, Dosimeter (any device) monitoring nuclear exposure

-----  
LAB0002-008 06/01/2022

	Rates	Fringes
LABORER (Compressed Air)		
0 - 15 POUNDS.....	\$ 48.40	33.16
16 - 20 POUNDS.....	\$ 48.90	33.16
21 - 26 POUNDS.....	\$ 49.40	33.16
27 - 33 POUNDS.....	\$ 50.40	33.16
34 - AND OVER.....	\$ 51.40	33.16
LABORER (Tunnel and Sewer)		
GROUP 1.....	\$ 47.40	33.16
GROUP 2.....	\$ 47.53	33.16
GROUP 3.....	\$ 47.63	33.16
GROUP 4.....	\$ 47.75	33.16
GROUP 5.....	\$ 47.40	33.16

LABORER CLASSIFICATIONS (TUNNEL)

GROUP 1: Cage tenders; Dumpmen; Flagmen; Signalmen; Top laborers

GROUP 2: Air hoist operator; Key board operator; concrete laborer; Grout; Lock tenders (Free Air Side); Steel setters; Tuggers; Switchmen; Car pusher

GROUP 3: Concrete repairmen; Lock tenders (pressure side); Mortar men; Muckers; Grout machine operators; Track layers

GROUP 4: Air trac drill operator; Miner; Bricklayer tenders; Concrete blower operator; Drillers; Dynamiters; Erector operator; Form men; Jackhammermen; Powerpac; Mining machine operators; Mucking machine operator; Laser beam operator; Liner plate and ring setters; Shield drivers; Power knife operator; Welder- burners; Pipe jacking machine operator; skimmers; Maintenance technician

GROUP 5: Asbestos abatement laborer; Toxic and hazardous waste removal laborer; Dosimeter (any device) monitoring nuclear exposure

LABORER CLASSIFICATIONS (SEWER)

GROUP 1: Signalmen; Top laborers and All other laborers

GROUP 2: Concrete laborers and Steel setters

GROUP 3: Cement carriers; Cement mixers; Concrete repairmen; Mortar men; Scaffold men; Second Bottom men

GROUP 4: Air trac drill operator; Bottom men; Bracers-bracing; Bricklayer tenders; Catch basin diggers; Drainlayers; dynamiters; Form men; Jackhammermen; Powerpac; Pipelayers; Rodders; Welder-burners; Well point systems men

GROUP 5: Asbestos abatement laborer, Toxic and hazardous waste removal laborer; Dosimeter (any device) monitoring nuclear exposure

-----  
LAB00225-001 06/01/2022

	Rates	Fringes
LABORER (DEMOLITION/WRECKING)		
GROUP 1.....	\$ 42.40	33.16
GROUP 2.....	\$ 47.40	33.16
GROUP 3.....	\$ 47.40	33.16

LABORER CLASSIFICATIONS

GROUP 1 - Complete Demolition

GROUP 2 - Interior Wrecking and Strip Out Work

GROUP 3 - Asbestos Work with Complete Demolition/Wrecking or Strip Out Work

-----  
PAIN0014-001 06/01/2022

	Rates	Fringes
PAINTER (including taper).....	\$ 50.30	31.07

-----  
PAIN0027-001 06/01/2022

	Rates	Fringes
GLAZIER.....	\$ 48.75	41.32

-----

PLAS0005-002 07/01/2015

	Rates	Fringes
PLASTERER.....	\$ 42.25	26.65

-----  
PLAS0502-001 06/01/2023

	Rates	Fringes
CEMENT MASON/CONCRETE FINISHER...	\$ 50.75	40.59

-----  
PLUM0130-001 06/01/2023

	Rates	Fringes
PLUMBER.....	\$ 56.80	36.02

-----  
PLUM0597-002 06/01/2023

	Rates	Fringes
PIPEFITTER.....	\$ 55.00	38.62

-----  
ROOF0011-001 06/01/2023

	Rates	Fringes
ROOFER.....	\$ 49.00	28.38

-----  
SFIL0281-001 01/01/2024

	Rates	Fringes
SPRINKLER FITTER.....	\$ 56.60	34.00

-----  
SHEE0073-001 06/01/2022

	Rates	Fringes
Sheet Metal Worker.....	\$ 49.10	42.91

-----  
SHEE0073-002 06/08/2018

	Rates	Fringes
Sheet Metal Worker ALUMINUM GUTTER WORK.....	\$ 31.32	37.02

-----  
TEAM0731-001 06/01/2017

COOK COUNTY - HEAVY AND HIGHWAY

	Rates	Fringes
TRUCK DRIVER		
2 or 3 Axles.....	\$ 35.60	22.10
4 Axles.....	\$ 35.85	22.10
5 Axles.....	\$ 36.05	22.10
6 Axles.....	\$ 36.25	22.10

FOOTNOTES:

A. Paid Holidays: New Year's Day, Memorial Day, Independence Day, Labor Day, Thanksgiving Day, and

Christmas Day.

B. 900 straight time hours or more in 1 calendar year for the same employer shall receive 1 week paid vacation; 3 years - 2 weeks paid vacation; 10 years - 3 weeks paid vacation; 20 years - 4 weeks paid vacation.

C. An additional \$.20 per axle shall be paid for all vehicles with more than six (6) axles.

-----  
TEAM0731-002 04/01/2023

	Rates	Fringes
Traffic Control Device Monitor		
TRAFFIC SAFETY WORKER:		
Primary duties include but are not limited to the delivery, maintenance and pick-up of traffic control devices, the set-up and installation of traffic signs, pavement markings, barricades, crash barrels and glare screens, traffic control surveillance, the repair and maintenance trucks, cars, arrow boards, message signs, barricade and sign fabrication equipment.....	\$ 40.10	20.95

-----  
TEAM0786-001 06/01/2017

COOK COUNTY - BUILDING AND RESIDENTIAL

	Rates	Fringes
TRUCK DRIVER		
2 & 3 Axles.....	\$ 39.942	0.25+a
4 Axles.....	\$ 39.75	0.25+a
5 Axles.....	\$ 39.967	0.25+a
6 Axles.....	\$ 40.184	0.25+a

FOOTNOTES:

a. \$719.00 per week.

An additional \$.20 per axle shall be paid for all vehicles with more than six (6) axles.

Paid Holidays: New Year's Day, Memorial Day, Independence Day, Labor Day, Thanksgiving Day, and Christmas Day.

900 straight time hours or more in 1 calendar year for the same employer shall receive 1 week paid vacation; 3 years - 2 weeks paid vacation; 10 years - 3 weeks paid vacation; 20 years - 4 weeks paid vacation.

-----  
WELDERS - Receive rate prescribed for craft performing operation to which welding is incidental.

=====  
 Note: Executive Order (EO) 13706, Establishing Paid Sick Leave for Federal Contractors applies to all contracts subject to the Davis-Bacon Act for which the contract is awarded (and any solicitation was issued) on or after January 1, 2017. If this contract is covered by the EO, the contractor must provide employees with 1 hour of paid sick leave for every 30 hours they work, up to 56 hours of paid sick leave each year. Employees must be permitted to use paid sick leave for their own illness, injury or other health-related needs, including preventive care; to assist a family member (or person who is like family to the employee) who is ill, injured, or has other health-related needs, including preventive care; or for reasons resulting from, or to assist a family member (or person who is like family to the employee) who is a victim of, domestic violence, sexual assault, or stalking. Additional information on contractor requirements and worker protections under the EO is available at <https://www.dol.gov/agencies/whd/government-contracts>.

Unlisted classifications needed for work not included within the scope of the classifications listed may be added after award only as provided in the labor standards contract clauses (29CFR 5.5 (a) (1) (iii)).

-----

The body of each wage determination lists the classification and wage rates that have been found to be prevailing for the cited type(s) of construction in the area covered by the wage determination. The classifications are listed in alphabetical order of ""identifiers"" that indicate whether the particular rate is a union rate (current union negotiated rate for local), a survey rate (weighted average rate) or a union average rate (weighted union average rate).

#### Union Rate Identifiers

A four letter classification abbreviation identifier enclosed in dotted lines beginning with characters other than ""SU"" or ""UAVG"" denotes that the union classification and rate were prevailing for that classification in the survey. Example: PLUM0198-005 07/01/2014. PLUM is an abbreviation identifier of the union which prevailed in the survey for this classification, which in this example would be Plumbers. 0198 indicates the local union number or district council number where applicable, i.e., Plumbers Local 0198. The next number, 005 in the example, is an internal number used in processing the wage determination. 07/01/2014 is the effective date of the most current negotiated rate, which in this example is July 1, 2014.

Union prevailing wage rates are updated to reflect all rate changes in the collective bargaining agreement (CBA) governing this classification and rate.

#### Survey Rate Identifiers

Classifications listed under the ""SU"" identifier indicate that no one rate prevailed for this classification in the survey and the published rate is derived by computing a weighted average rate based on all the rates reported in the survey for that

classification. As this weighted average rate includes all rates reported in the survey, it may include both union and non-union rates. Example: SULA2012-007 5/13/2014. SU indicates the rates are survey rates based on a weighted average calculation of rates and are not majority rates. LA indicates the State of Louisiana. 2012 is the year of survey on which these classifications and rates are based. The next number, 007 in the example, is an internal number used in producing the wage determination. 5/13/2014 indicates the survey completion date for the classifications and rates under that identifier.

Survey wage rates are not updated and remain in effect until a new survey is conducted.

#### Union Average Rate Identifiers

Classification(s) listed under the UAVG identifier indicate that no single majority rate prevailed for those classifications; however, 100% of the data reported for the classifications was union data. EXAMPLE: UAVG-OH-0010 08/29/2014. UAVG indicates that the rate is a weighted union average rate. OH indicates the state. The next number, 0010 in the example, is an internal number used in producing the wage determination. 08/29/2014 indicates the survey completion date for the classifications and rates under that identifier.

A UAVG rate will be updated once a year, usually in January of each year, to reflect a weighted average of the current negotiated/CBA rate of the union locals from which the rate is based.

---

#### WAGE DETERMINATION APPEALS PROCESS

1.) Has there been an initial decision in the matter? This can be:

- \* an existing published wage determination
- \* a survey underlying a wage determination
- \* a Wage and Hour Division letter setting forth a position on a wage determination matter
- \* a conformance (additional classification and rate) ruling

On survey related matters, initial contact, including requests for summaries of surveys, should be with the Wage and Hour National Office because National Office has responsibility for the Davis-Bacon survey program. If the response from this initial contact is not satisfactory, then the process described in 2.) and 3.) should be followed.

With regard to any other matter not yet ripe for the formal process described here, initial contact should be with the Branch of Construction Wage Determinations. Write to:

Branch of Construction Wage Determinations  
Wage and Hour Division  
U.S. Department of Labor  
200 Constitution Avenue, N.W.  
Washington, DC 20210

2.) If the answer to the question in 1.) is yes, then an interested party (those affected by the action) can request

review and reconsideration from the Wage and Hour Administrator (See 29 CFR Part 1.8 and 29 CFR Part 7). Write to:

Wage and Hour Administrator  
U.S. Department of Labor  
200 Constitution Avenue, N.W.  
Washington, DC 20210

The request should be accompanied by a full statement of the interested party's position and by any information (wage payment data, project description, area practice material, etc.) that the requestor considers relevant to the issue.

3.) If the decision of the Administrator is not favorable, an interested party may appeal directly to the Administrative Review Board (formerly the Wage Appeals Board). Write to:

Administrative Review Board  
U.S. Department of Labor  
200 Constitution Avenue, N.W.  
Washington, DC 20210

4.) All decisions by the Administrative Review Board are final.

=====

END OF GENERAL DECISION"



## **\*BUILD AMERICA, BUY AMERICA ACT (BABAA)**

1. The Build America, Buy America Act (BABA), enacted on November 15, 2021, as part of the Infrastructure Investment and Jobs Act (ITJA). Pub. L. 117-58. The Act establishes a domestic content procurement preference (“Buy America Preference” or “BAP”) for federal infrastructure programs. The term “domestic content procurement preference” means a requirement that no amounts made available through a program for Federal financial assistance may be obligated for a project unless:
  - a. all iron and steel used in the project are produced in the United States;
  - b. the manufactured products used in the project are produced in the United States; or
  - c. the construction materials used in the project are produced in the United States.
2. Steps developed by HUD must be implemented to ensure that the iron, steel, manufactured products, and construction materials used in a project are produced in the United States. Section 70912, the Act further defines a project to include “the construction, alteration, maintenance, or repair of infrastructure in the United States” and includes within the definition of infrastructure those items traditionally included along with buildings and real property. The term “infrastructure” includes, at a minimum, the structure, facilities, and equipment for, the in the United State:
  - a. roads, highways, and bridges;
  - b. public transportation;
  - c. dams, ports, harbors, and other maritime facilities;
  - d. intercity passenger and freight railroads;
  - e. freight and intermodal facilities;
  - f. airports;
  - g. water systems, including drinking water and wastewater systems;
  - h. electrical transmission facilities and systems;
  - i. utilities;
  - j. broadband infrastructure; and
  - k. buildings and real property.
3. CDBG funds awarded under the AGREEMENT are subject to the provisions of the Act, 41 U.S.C. 8301 note. While HUD currently has a waiver of the application of the BAP through HUD’s Notice, “General Applicability Waiver of Build America, Buy America Provisions as Applied to Recipients of HUD Federal Financial Assistance” (87 FR 26219), HUD will begin requiring compliance with BAP for all new funds obligated on or after November 14, 2022, unless covered by a subsequent waiver. Under FR-6331-N-06, HUD has proposed phased implementation of the BAP.

The BAP applies to the following construction materials used in infrastructure projects. Each construction material is followed by a standard for the material to be considered “**produced in the United States.**”

- a. ***Non-ferrous metals.*** All manufacturing processes, from initial smelting or melting through final shaping, coating, and assembly, occurred in the United States.
- b. ***Plastic and polymer-based products.*** All manufacturing processes, from initial combination

of constituent, plastic or polymer-based inputs until the item is in a form in which it is delivered to the work site and incorporated into the project, occurred in the United States.

- c. **Composite building materials.** All manufacturing processes, from initial combination of constituent materials until the composite material is in a form in which it is delivered to the work site and incorporated into the project, occurred in the United States.
- d. **Glass.** All manufacturing processes, from initial batching and melting of raw materials through annealing, cooling, and cutting, occurred in the United States.
- e. **Fiber optic cable.** All manufacturing processes, from the initial preform fabrication stage through fiber stranding and jacketing, occurred in the United States.
- f. **Optical fiber.** All manufacturing processes, from the initial preform fabrication stage through fiber stranding, occurred in the United States.
- g. **Lumber.** All manufacturing processes, from initial debarking through treatment and planning, occurred in the United States.
- h. **Drywall.** All manufacturing processes, from initial blending of mined or synthetic gypsum plaster and additives through cutting and drying of sandwiched panels, occurred in the United States.

Documented evidence proving the iron, steel, manufactured products, and construction materials used in a project are produced in the United States must be provided to the CDC. Examples of evidence include, but are not limited to: documented review of material submittals ensuring proposed covered items are produced in the USA; photos of product labels/stamps and engineering notes from field visits to inspect materials prior to use, confirmed covered items were manufactured in the USA; invoices certifying covered items are manufactured in the USA.

**ADDITIONAL REQUIRED  
ATTACHMENTS**

## A. APPLICABILITY

The Project or Program to which the construction work covered by this Contract pertains is being assisted by the United States of America, and the following Federal Labor Standards Provisions are included in this Contract pursuant to the provisions applicable to such Federal assistance.

### 1. Minimum wages and fringe benefits

All laborers and mechanics employed or working upon the site of the work (or otherwise working in construction or development of the project under a development statute), will be paid unconditionally and not less often than once a week, and without subsequent deduction or rebate on any account (except such payroll deductions as are permitted by regulations issued by the Secretary of Labor under the Copeland Act (29 CFR part 3)), the full amount of basic hourly wages and bona fide fringe benefits (or cash equivalents thereof) due at time of payment computed at rates not less than those contained in the wage determination of the Secretary of Labor which is attached hereto and made a part hereof, regardless of any contractual relationship which may be alleged to exist between the contractor and such laborers and mechanics. As provided in 29 CFR 5.5(d) and (e), the appropriate wage determinations are effective by operation of law even if they have not been attached to the contract. Contributions made or costs reasonably anticipated for bona fide fringe benefits under the Davis-Bacon Act (40 U.S.C. 3141(2)(B)) on behalf of laborers or mechanics are considered wages paid to such laborers or mechanics, subject to the provisions of paragraph (a)(1)(v) of these contract clauses; also, regular contributions made or costs incurred for more than a weekly period (but not less often than quarterly) under plans, funds, or programs which cover the particular weekly period, are deemed to be constructively made or incurred during such weekly period. Such laborers and mechanics must be paid the appropriate wage rate and fringe benefits on the wage determination for the classification(s) of work actually performed, without regard to skill, except as provided in 29 CFR 5.5(a)(4). Laborers or mechanics performing work in more than one classification may be compensated at the rate specified for each classification for the time actually worked therein: *Provided*, That the employer's payroll records accurately set forth the time spent in each classification in which work is performed. The wage determination (including any additional classifications and wage rates conformed under 29 CFR 5.5(a)(1)(iii)) and the Davis-Bacon poster (WH-1321) must be posted at all times by the contractor and its subcontractors at the site of the work in a prominent and accessible place where it can be easily seen by the workers.

### 2. Frequently recurring classifications

In addition to wage and fringe benefit rates that have been determined to be prevailing under the procedures set forth in 29 CFR part 1, a wage determination may contain, pursuant to § 1.3(f), wage and fringe benefit rates for classifications of laborers and mechanics for which conformance requests are regularly submitted pursuant to 29 CFR 5.5(a)(1)(iii), provided that:

- A. The work performed by the classification is not performed by a classification in the wage determination for which a prevailing wage rate has been determined;
- B. The classification is used in the area by the construction industry; and
- C. The wage rate for the classification bears a reasonable relationship to the prevailing wage rates contained in the wage determination.
- D. The Administrator will establish wage rates for such

classifications in accordance with 29 CFR 5.5(a)(1)(iii)(A)(3). Work performed in such a classification must be paid at no less than the wage and fringe benefit rate listed on the wage determination for such classification.

### 3. Conformance

A. The contracting officer must require that any class of laborers or mechanics, including helpers, which is not listed in the wage determination, and which is to be employed under the contract be classified in conformance with the wage determination. Conformance of an additional classification and wage rate and fringe benefits is appropriate only when the following criteria have been met:

B. The work to be performed by the classification requested is not performed by a classification in the wage determination; and

C. The classification is used in the area by the construction industry; and

D. The proposed wage-rate, including any bona fide fringe benefits, bears a reasonable relationship to the wage rates contained in the wage determination.

E. The conformance process may not be used to split, subdivide, or otherwise avoid application of classifications listed in the wage determination.

F. If the contractor and the laborers and mechanics to be employed in the classification (if known), or their representatives, and the contracting officer agree on the classification and wage rate (including the amount designated for fringe benefits where appropriate), a report of the action taken will be sent by the contracting officer by email to [DBAconformance@dol.gov](mailto:DBAconformance@dol.gov). The Administrator, or an authorized representative, will approve, modify, or disapprove every additional classification action within 30 days of receipt and so advise the contracting officer or will notify the contracting officer within the 30-day period that additional time is necessary.

G. In the event the contractor, the laborers or mechanics to be employed in the classification or their representatives, and the contracting officer do not agree on the proposed classification and wage rate (including the amount designated for fringe benefits, where appropriate), the contracting officer will, by email to [DBAconformance@dol.gov](mailto:DBAconformance@dol.gov), refer the questions, including the views of all interested parties and the recommendation of the contracting officer, to the Administrator for determination. The Administrator, or an authorized representative, will issue a determination within 30 days of receipt and so advise the contracting officer or will notify the contracting officer within the 30-day period that additional time is necessary.

H. The contracting officer must promptly notify the contractor of the action taken by the Wage and Hour Division under 29 CFR 5.5(a)(1)(iii)(C) and (D). The contractor must furnish a written copy of such determination to each affected worker, or it must be posted as a part of the wage determination. The wage rate (including fringe benefits where appropriate) determined pursuant to 29 CFR 5.5(a)(1)(iii)(C) or (D) must be paid to all workers performing work in the classification under this contract from the first day on which work is performed in the classification.

### 4. Fringe benefits not expressed as an hourly rate

Whenever the minimum wage rate prescribed in the contract for a class of laborers or mechanics includes a fringe benefit which is not expressed as an hourly rate, the contractor may either pay the benefit as stated in the wage determination or may pay another bona fide fringe benefit or an hourly cash equivalent thereof.

## 5. Unfunded plans

If the contractor does not make payments to a trustee or other third person, the contractor may consider as part of the wages of any laborer or mechanic the amount of any costs reasonably anticipated in providing bona fide fringe benefits under a plan or program, *Provided*, That the Secretary of Labor has found, upon the written request of the contractor, in accordance with the criteria set forth in 29 CFR 5.28, that the applicable standards of the Davis-Bacon Act have been met. The Secretary of Labor may require the contractor to set aside in a separate account assets for the meeting of obligations under the plan or program.

**6. Interest** In the event of a failure to pay all or part of the wages required by the contract, the contractor will be required to pay interest on any underpayment of wages.

## 7. Withholding

### A. Withholding requirements

The U. S. Department of Housing and Urban Development may, upon its own action, or must, upon written request of an authorized representative of the Department of Labor, withhold or cause to be withheld from the contractor so much of the accrued payments or advances as may be considered necessary to satisfy the liabilities of the prime contractor or any subcontractor for the full amount of wages and monetary relief, including interest, required by the clauses set forth in 29 CFR 5.5(a) for violations of this contract, or to satisfy any such liabilities required by any other Federal contract, or federally assisted contract subject to Davis-Bacon labor standards, that is held by the same prime contractor (as defined in 29 CFR 5.2). The necessary funds may be withheld from the contractor under this contract, any other Federal contract with the same prime contractor, or any other federally assisted contract that is subject to Davis-Bacon labor standards requirements and is held by the same prime contractor, regardless of whether the other contract was awarded or assisted by the same agency, and such funds may be used to satisfy the contractor liability for which the funds were withheld. In the event of a contractor's failure to pay any laborer or mechanic, including any apprentice or helper working on the site of the work (or otherwise working in construction or development of the project under a development statute) all or part of the wages required by the contract, or upon the contractor's failure to submit the required records as discussed in 29 CFR 5.5(a)(3)(iv), HUD may on its own initiative and after written notice to the contractor, sponsor, applicant, owner, or other entity, as the case may be, take such action as may be necessary to cause the suspension of any further payment, advance, or guarantee of funds until such violations have ceased.

### B. Priority to withheld funds

The Department has priority to funds withheld or to be withheld in accordance with 29 CFR 5.5(a)(2)(i) or (b)(3)(i), or both, over claims to those funds by:

C. A contractor's surety(ies), including without limitation performance bond sureties and payment bond sureties;

D. A contracting agency for its re-procurement costs;

E. A trustee(s) (either a court-appointed trustee or a U.S. trustee, or both) in bankruptcy of a contractor, or a contractor's bankruptcy estate;

F. A contractor's assignee(s);

G. A contractor's successor(s); or

H. A claim asserted under the Prompt Payment Act, 31 U.S.C. 3901-3907.

## 8. Records and certified payrolls

## 9. Basic record requirements

**10. Length of record retention.** All regular payrolls and other basic records must be maintained by the contractor and any subcontractor during the course of the work and preserved for all laborers and mechanics working at the site of the work (or otherwise working in construction or development of the project under a development statute) for a period of at least 3 years after all the work on the prime contract is completed.

**11. Information required** Such records must contain the name; Social Security number; last known address, telephone number, and email address of each such worker; each worker's correct classification(s) of work actually performed; hourly rates of wages paid (including rates of contributions or costs anticipated for bona fide fringe benefits or cash equivalents thereof of the types described in 40 U.S.C. 3141(2)(B) of the Davis-Bacon Act); daily and weekly number of hours actually worked in total and on each covered contract; deductions made; and actual wages paid.

**12. Additional records relating to fringe benefits.** Whenever the Secretary of Labor has found under 29 CFR 5.5(a)(1)(v) that the wages of any laborer or mechanic include the amount of any costs reasonably anticipated in providing benefits under a plan or program described in 40

U.S.C. 3141(2)(B) of the Davis-Bacon Act, the contractor must maintain records which show that the commitment to provide such benefits is enforceable, that the plan or program is financially responsible, and that the plan or program has been communicated in writing to the laborers or mechanics affected, and records which show the costs anticipated or the actual cost incurred in providing such benefits.

**13. Additional records relating to apprenticeship** Contractors with apprentices working under approved programs must maintain written evidence of the registration of apprenticeship programs, the registration of the apprentices, and the ratios and wage rates prescribed in the applicable programs.

## 14. Certified payroll requirements

**15. Frequency and method of submission** The contractor or subcontractor must submit weekly, for each week in which any DBA- or Related Acts-covered work is performed, certified payrolls to HUD if the agency is a party to the contract, but if the agency is not such a party, the contractor will submit the certified payrolls to the applicant, sponsor, owner, or other entity, as the case may be, that maintains such records, for transmission to HUD. The prime contractor is responsible for the submission of all certified payrolls by all subcontractors. A contracting agency or prime contractor may permit or require contractors to submit certified payrolls through an electronic system, as long as the electronic system requires a legally valid electronic signature; the system allows the contractor, the contracting agency, and the Department of Labor to access the certified payrolls upon request for at least 3 years after the work on the prime contract has been completed; and the contracting agency or prime contractor permits other methods of submission in situations where the contractor is unable or limited in its ability to use or access the electronic system

**16. Information required** The certified payrolls submitted must set out accurately and completely all of the information required to be maintained under 29 CFR 5.5(a)(3)(i)(B), except that full Social Security numbers and last known addresses, telephone numbers, and email addresses must not be included on weekly transmittals. Instead, the certified payrolls need only include an individually identifying number for each worker (*e.g.*, the last four digits of the worker's Social Security

number). The required weekly certified payroll information may be submitted using Optional Form WH-347 or in any other format desired. Optional Form WH-347 is available for this purpose from the Wage and Hour Division Web site at: <https://www.dol.gov/sites/dolgov/files/WHD/legacy/files/wh347.pdf> or its successor website. It is not a violation of this section for a prime contractor to require a subcontractor to provide full Social Security numbers and last known addresses, telephone numbers, and email addresses to the prime contractor for its own records, without weekly submission by the subcontractor to the sponsoring government agency (or the applicant, sponsor, owner, or other entity, as the case may be, that maintains such records).

**17. Statement of Compliance** Each certified payroll submitted must be accompanied by a “Statement of Compliance,” signed by the contractor or subcontractor, or the contractor’s or subcontractor’s agent who pays or supervises the payment of the persons working on the contract, and must certify the following:

A. That the certified payroll for the payroll period contains the information required to be provided under 29 CFR 5.5(a)(3)(ii), the appropriate information and basic records are being maintained under 29 CFR 5.5 (a)(3)(i), and such information and records are correct and complete;

B. That each laborer or mechanic (including each helper and apprentice) working on the contract during the payroll period has been paid the full weekly wages earned, without rebate, either directly or indirectly, and that no deductions have been made either directly or indirectly from the full wages earned, other than permissible deductions as set forth in 29 CFR part 3; and

C. That each laborer or mechanic has been paid not less than the applicable wage rates and fringe benefits or cash equivalents for the classification(s) of work actually performed, as specified in the applicable wage determination incorporated into the contract.

**18. Use of Optional Form WH-347** The weekly submission of a properly executed certification set forth on the reverse side of Optional Form WH-347 will satisfy the requirement for submission of the “Statement of Compliance” required by 29 CFR 5.5(a)(3)(ii)(C).

**19. Signature** The signature by the contractor, subcontractor, or the contractor’s or subcontractor’s agent must be an original handwritten signature or a legally valid electronic signature.

**20. Falsification** The falsification of any of the above certifications may subject the contractor or subcontractor to civil or criminal prosecution under 18 U.S.C. 1001 and 31 U.S.C. 3729.

**21. Length of certified payroll retention** The contractor or subcontractor must preserve all certified payrolls during the course of the work and for a period of 3 years after all the work on the prime contract is completed.

**22. Contracts, subcontracts, and related documents** The contractor or subcontractor must maintain this contract or subcontract and related documents including, without limitation, bids, proposals, amendments, modifications, and extensions. The contractor or subcontractor must preserve these contracts, subcontracts, and related documents during the course of the work and for a period of 3 years after all the work on the prime contract is completed.

**23. Required disclosures and access**

**24. Required record disclosures and access to workers** The contractor or subcontractor must make the records required under 29 CFR 5.5(a)(3)(i)–(iii), and any other documents that HUD or the Department of Labor deems necessary to determine compliance with the labor standards provisions of any of the applicable statutes referenced by 29

CFR 5.1, available for inspection, copying, or transcription by authorized representatives of HUD or the Department of Labor, and must permit such representatives to interview workers during working hours on the job.

**25. Sanctions for non-compliance with records and worker access requirements** If the contractor or subcontractor fails to submit the required records or to make them available, or refuses to permit worker interviews during working hours on the job, the Federal agency may, after written notice to the contractor, sponsor, applicant, owner, or other entity, as the case may be, that maintains such records or that employs such workers, take such action as may be necessary to cause the suspension of any further payment, advance, or guarantee of funds. Furthermore, failure to submit the required records upon request or to make such records available, or to permit worker interviews during working hours on the job, may be grounds for debarment action pursuant to 29 CFR 5.12. In addition, any contractor or other person that fails to submit the required records or make those records available to WHD within the time WHD requests that the records be produced will be precluded from introducing as evidence in an administrative proceeding under 29 CFR part 6 any of the required records that were not provided or made available to WHD. WHD will take into consideration a reasonable request from the contractor or person for an extension of the time for submission of records. WHD will determine the reasonableness of the request and may consider, among other things, the location of the records and the volume of production.

**26. Required information disclosures** Contractors and subcontractors must maintain the full Social Security number and last known address, telephone number, and email address of each covered worker, and must provide them upon request to HUD if the agency is a party to the contract, or to the Wage and Hour Division of the Department of Labor. If the Federal agency is not such a party to the contract, the contractor, subcontractor, or both, must, upon request, provide the full Social Security number and last known address, telephone number, and email address of each covered worker to the applicant, sponsor, owner, or other entity, as the case may be, that maintains such records, for transmission to HUD, the contractor, or the Wage and Hour Division of the Department of Labor for purposes of an investigation or other compliance action.

**27. Apprentices and equal employment opportunity**

**28. Apprentices Rate of pay** Apprentices will be permitted to work at less than the predetermined rate for the work they perform when they are employed pursuant to and individually registered in a bona fide apprenticeship program registered with the U.S. Department of Labor, Employment and Training Administration, Office of Apprenticeship (OA), or with a State Apprenticeship Agency recognized by the OA. A person who is not individually registered in the program, but who has been certified by the OA or a State Apprenticeship Agency (where appropriate) to be eligible for probationary employment as an apprentice, will be permitted to work at less than the predetermined rate for the work they perform in the first 90 days of probationary employment as an apprentice in such a program. In the event the OA or a State Apprenticeship Agency recognized by the OA withdraws approval of an apprenticeship program, the contractor will no longer be permitted to use apprentices at less than the applicable predetermined rate for the work performed until an acceptable

program is approved.

**29. Fringe benefits** Apprentices must be paid fringe benefits in accordance with the provisions of the apprenticeship program. If the apprenticeship program does not specify fringe benefits, apprentices must be paid the full amount of fringe benefits listed on the wage determination for the applicable classification. If the Administrator determines that a different practice prevails for the applicable apprentice classification, fringe benefits must be paid in accordance with that determination.

**30. Apprenticeship ratio** The allowable ratio of apprentices to journey workers on the job site in any craft classification must not be greater than the ratio permitted to the contractor as to the entire work force under the registered program or the ratio applicable to the locality of the project pursuant to 29 CFR 5.5(a)(4)(i)(D). Any worker listed on a payroll at an apprentice wage rate, who is not registered or otherwise employed as stated in 29 CFR 5.5(a)(4)(i)(A), must be paid not less than the applicable wage rate on the wage determination for the classification of work actually performed. In addition, any apprentice performing work on the job site in excess of the ratio permitted under this section must be paid not less than the applicable wage rate on the wage determination for the work actually performed.

**31. Reciprocity of ratios and wage rates** Where a contractor is performing construction on a project in a locality other than the locality in which its program is registered, the ratios and wage rates (expressed in percentages of the journey worker's hourly rate) applicable within the locality in which the construction is being performed must be observed. If there is no applicable ratio or wage rate for the locality of the project, the ratio and wage rate specified in the contractor's registered program must be observed.

**32. Equal employment opportunity** The use of apprentices and journey workers under this part must be in conformity with the equal employment opportunity requirements of Executive Order 11246, as amended, and 29 CFR part 30.

**33. Compliance with Copeland Act requirements.** The contractor shall comply with the requirements of 29 CFR part 3, which are incorporated by reference in this contract.

**A. Subcontracts.** The contractor or subcontractor must insert in any subcontracts the clauses contained in 29 CFR 5.5(a)(1) through (11), along with the applicable wage determination(s) and such other clauses or contract modifications as the U.S. Department of Housing and Urban Development may by appropriate instructions require, and a clause requiring the subcontractors to include these clauses and wage determination(s) in any lower tier subcontracts. The prime contractor is responsible for the compliance by any subcontractor or lower tier subcontractor with all the contract clauses in this section. In the event of any violations of these clauses, the prime contractor and any subcontractor(s) responsible will be liable for any unpaid wages and monetary relief, including interest from the date of the underpayment or loss, due to any workers of lower-tier subcontractors, and may be subject to debarment, as appropriate.

**B. Contract termination: debarment.** A breach of the contract clauses in 29 CFR 5.5 may be grounds for termination of the contract, and for debarment as a contractor and a subcontractor as provided in 29 CFR 5.12.

**C. Compliance with Davis-Bacon and Related Act requirements.** All rulings and interpretations of the Davis-Bacon and Related Acts contained in 29 CFR parts 1, 3, and 5 are herein incorporated by reference in this contract.

**D. Disputes concerning labor standards.** Disputes arising out of

the labor standards provisions of this contract shall not be subject to the general disputes clause of this contract. Such disputes shall be resolved in accordance with the procedures of the Department of Labor set forth in 29 CFR parts 5, 6, and 7. Disputes within the meaning of this clause include disputes between the contractor (or any of its subcontractors) and the contracting agency, the U.S. Department of Labor, or the employees or their representatives.

**E. Certification of eligibility.**

i. By entering into this contract, the contractor certifies that neither it nor any person or firm who has an interest in the contractor's firm is a person or firm ineligible to be awarded Government contracts by virtue of 40 U.S.C. 3144(b) or 29 CFR 5.12(a).

ii. No part of this contract shall be subcontracted to any person or firm ineligible for award of a Government contract by virtue of 40 U.S.C. 3144(b) or 29 CFR 5.12(a).

iii. The penalty for making false statements is prescribed in the U.S. Code, Title 18 Crimes and Criminal Procedure, 18 U.S.C. 1001.

**F. Anti-retaliation** It is unlawful for any person to discharge, demote, intimidate, threaten, restrain, coerce, blacklist, harass, or in any other manner discriminate against, or to cause any person to discharge, demote, intimidate, threaten, restrain, coerce, blacklist, harass, or in any other manner discriminate against, any worker or job applicant for:

i. Notifying any contractor of any conduct which the worker reasonably believes constitutes a violation of the DBA, Related Acts, or 29 CFR parts 1, 3, or 5;

ii. Filing any complaint, initiating or causing to be initiated any proceeding, or otherwise asserting or seeking to assert on behalf of themselves or others any right or protection under the DBA, Related Acts, or 29 CFR parts 1, 3, or 5;

iii. Cooperating in any investigation or other compliance action, or testifying in any proceeding under the DBA, Related Acts, or 29 CFR parts 1, 3, or 5; or

iv. Informing any other person about their rights under the DBA, Related Acts, or 29 CFR parts 1, 3, or 5.

**34. Contract Work Hours and Safety Standards Act (CWHSSA)**

The Agency Head must cause or require the contracting officer to insert the following clauses set forth in 29 CFR 5.5(b)(1), (2), (3), (4), and (5) in full, or (for contracts covered by the Federal Acquisition Regulation) by reference, in any contract in an amount in excess of \$100,000 and subject to the overtime provisions of the Contract Work Hours and Safety Standards Act. These clauses must be inserted in addition to the clauses required by 29 CFR 5.5(a) or 4.6. As used in this paragraph, the terms "laborers and mechanics" include watchpersons and guards.

**A. Overtime requirements.** No contractor or subcontractor contracting for any part of the contract work which may require or involve the employment of laborers or mechanics shall require or permit any such laborer or mechanic in any workweek in which he or she is employed on such work to work in excess of forty hours in such workweek unless such laborer or mechanic receives compensation at a rate not less than one and one-half times the basic rate of pay for all hours worked in excess of forty hours in such workweek.

**B. Violation; liability for unpaid wages; liquidated damages.** In the event of any violation of the clause set forth in 29 CFR 5.5(b)(1) the contractor and any subcontractor responsible therefor shall be liable for the unpaid wages and interest from the date of the underpayment. In addition, such contractor and subcontractor shall be liable to the United States (in the case of work done under contract for the District of Columbia or a territory, to such District or to such territory), for

liquidated damages. Such liquidated damages shall be computed with respect to each individual laborer or mechanic, including watchpersons and guards, employed in violation of the clause set forth in 29 CFR 5.5(b)(1), in the sum of \$31 for each calendar day on which such individual was required or permitted to work in excess of the standard workweek of forty hours without payment of the overtime wages required by the clause set forth in 29 CFR 5.5(b)(1).

**35. Withholding for unpaid wages and liquidated damages**

**A. Withholding process** The U.S. Department of Housing and Urban Development or the recipient of Federal assistance may, upon its own action, or must, upon written request of an authorized representative of the Department of Labor, withhold or cause to be withheld from the contractor so much of the accrued payments or advances as may be considered necessary to satisfy the liabilities of the prime contractor or any subcontractor for any unpaid wages; monetary relief, including interest; and liquidated damages required by the clauses set forth in 29 CFR 5.5(b) on this contract, any other Federal contract with the same prime contractor, or any other federally assisted contract subject to the Contract Work Hours and Safety Standards Act that is held by the same prime contractor (as defined in 29 CFR 5.2). The necessary funds may be withheld from the contractor under this contract, any other Federal contract with the same prime contractor, or any other federally assisted contract that is subject to the Contract Work Hours and Safety Standards Act and is held by the same prime contractor, regardless of whether the other contract was awarded or assisted by the same agency, and such funds may be used to satisfy the contractor liability for which the funds were withheld.

**B. Priority to withheld funds** The Department has priority to funds withheld or to be withheld in accordance with 29 CFR 5.5(a)(2)(i) or (b)(3)(i), or both, over claims to those funds by:

- i. A contractor's surety(ies), including without limitation performance bond sureties and payment bond sureties;
- ii. A contracting agency for its re-procurement costs;
- iv. A trustee(s) (either a court-appointed trustee or a U.S. trustee, or both) in bankruptcy of a contractor, or a contractor's bankruptcy estate;
- v. A contractor's assignee(s);
- vi. A contractor's successor(s); or
- vii. A claim asserted under the Prompt Payment Act, 31 U.S.C. 3901-3907.

**C. Subcontracts.** The contractor or subcontractor must insert in any subcontracts the clauses set forth in 29 CFR 5.5(b)(1) through (5) and a clause requiring the subcontractors to include these clauses in any lower tier subcontracts. The prime contractor is responsible for compliance by any subcontractor or lower tier subcontractor with the clauses set forth in 29 CFR 5.5(b)(1) through (5). In the event of any violations of these clauses, the prime contractor and any subcontractor(s) responsible will be liable for any unpaid wages and monetary relief, including interest from the date of the underpayment or loss, due to any workers of lower-tier subcontractors, and associated liquidated damages and may be subject to debarment, as appropriate.

**D. Anti-retaliation** It is unlawful for any person to discharge, demote, intimidate, threaten, restrain, coerce, blacklist, harass, or in any other manner discriminate against, or to cause any person to discharge, demote, intimidate, threaten, restrain, coerce, blacklist, harass, or in any other manner discriminate against, any worker or job applicant for:

i. Notifying any contractor of any conduct which the worker reasonably believes constitutes a violation of the Contract Work Hours and Safety Standards Act (CWHSSA) or its implementing regulations in 29 CFR part 5;

ii. Filing any complaint, initiating or causing to be initiated any proceeding, or otherwise asserting or seeking to assert on behalf of themselves or others any right or protection under CWHSSA or 29 CFR part 5;

iii. Cooperating in any investigation or other compliance action, or testifying in any proceeding under CWHSSA or 29 CFR part 5; or Informing any other person about their rights under CWHSSA or 29 CFR part 5.

**36. CWHSSA required records clause** In addition to the clauses contained in 29 CFR 5.5(b), in any contract subject only to the Contract Work Hours and Safety Standards Act and not to any of the other laws referenced by 29 CFR 5.1, the Agency Head must cause or require the contracting officer to insert a clause requiring that the contractor or subcontractor must maintain regular payrolls and other basic records during the course of the work and must preserve them for a period of 3 years after all the work on the prime contract is completed for all laborers and mechanics, including guards and watchpersons, working on the contract. Such records must contain the name; last known address, telephone number, and email address; and social security number of each such worker; each worker's correct classification(s) of work actually performed; hourly rates of wages paid; daily and weekly number of hours actually worked; deductions made and actual wages paid. Further, the Agency Head must cause or require the contracting officer to insert in any such contract a clause providing that the records to be maintained under this paragraph must be made available by the contractor or subcontractor for inspection, copying, or transcription by authorized representatives of the (write the name of agency) and the Department of Labor, and the contractor or subcontractor will permit such representatives to interview workers during working hours on the job.

**37. Incorporation of contract clauses and wage determinations by reference** Although agencies are required to insert the contract clauses set forth in this section, along with appropriate wage determinations, in full into covered contracts, and contractors and subcontractors are required to insert them in any lower-tier subcontracts, the incorporation by reference of the required contract clauses and appropriate wage determinations will be given the same force and effect as if they were inserted in full text.

**38. Incorporation by operation of law** The contract clauses set forth in this section (or their equivalent under the Federal Acquisition Regulation), along with the correct wage determinations, will be considered to be a part of every prime contract required by the applicable statutes referenced by 29 CFR 5.1 to include such clauses, and will be effective by operation of law, whether or not they are included or incorporated by reference into such contract, unless the Administrator grants a variance, tolerance, or exemption from the application of this paragraph. Where the clauses and applicable wage determinations are effective by operation of law under this paragraph, the prime contractor must be compensated for any resulting increase in wages in accordance with applicable law.

**39. HEALTH AND SAFETY**

The provisions of this paragraph (F) are applicable where the amount of the prime contract exceeds \$100,000.

A. No laborer or mechanic shall be required to work in surroundings or under working conditions which are unsanitary,



hazardous, or dangerous to his or her health and safety, as determined under construction safety and health standards promulgated by the Secretary of Labor by regulation.

B. The contractor shall comply with all regulations issued by the Secretary of Labor pursuant to 29 CFR Part 1926 and failure to comply may result in imposition of sanctions pursuant to the Contract Work Hours and Safety Standards Act, (Public Law 91-54, 83 Stat 96), 40 U.S.C. § 3701 et seq.

C. The contractor shall include the provisions of this paragraph in every subcontract, so that such provisions will be binding on each subcontractor. The contractor shall take such action with respect to any subcontractor as the Secretary of Housing and Urban Development or the Secretary of Labor shall direct as a means of enforcing such provisions.

## **COOK COUNTY CONTRACT COMPLIANCE SPECIAL PROVISIONS FOR MINORITY AND WOMEN BUSINESS ENTERPRISE**

### *Responding to a Bid for Proposal*

A Bidder or Proposer shall document its commitment to meeting the Contract specific MBE and WBE participation goals by submitting a Utilization Plan with the Bid or Proposal. The Utilization Plan shall include (1) one or more Letter(s) of Intent from the relevant MBE and WBE firms; and (2) current Letters of Certification as an MBE or WBE. Alternatively, the Bidder or Proposer shall submit (1) a written Petition for Reduction/Waiver with the Bid, Quotation or Proposal, which documents its preceding Good Faith Efforts and an explanation of its inability to meet the goals for MBE and WBE participation. The Utilization Plan shall be submitted at the time that the bid or proposal is due.

### *Utilization Plan*

Each Bid or Proposal shall include a complete Utilization Plan, as set forth on Form 1 of the M/WBE Compliance Forms. The Utilization Plan shall include the name(s), mailing address, email address, and telephone number of the principal contact person of the relevant MBE and WBE firms. If the Bidder or Proposer submits a Bid or Proposal, and any of their subcontractors, suppliers or consultants, are certified MBE or WBE firms, they shall be identified as an MBE or WBE within the Utilization Plan.

### *Letter of Intent (LOI)*

Except as set forth below, a Bid or Proposal shall include, as part of the Utilization Plan, one or more Letter(s) of Intent, as set forth on Form 2 of the M/WBE Compliance Forms, executed by each MBE and WBE and the Bidder or Proposer. The Letter(s) of Intent will be used to confirm that each MBE and WBE shall perform work as a subcontractor, supplier, joint venture, or consultant on the Contract. Each Letter of Intent shall indicate whether and the degree to which the MBE or WBE will provide goods or services directly or indirectly during the term of the Contract. The box for direct participation shall be marked if the proposed MBE or WBE will provide goods or services directly related to the scope of the Contract. The box for Indirect participation shall be marked if the proposed MBE or WBE will not be directly involved in the Contract but will be utilized by the Bidder or Proposer for other services not related to the Contract. Each Letter of Intent shall accurately detail the work to be performed by the relevant MBE or WBE firm, the agreed dollar amount, the percentage of work, and the terms of payment.

### *Petition for Partial or Full Reduction of Participation*

In the event a Bid or Proposal does not meet the Contract specific goals for MBE and WBE participation, the Bid or Proposal shall include a Petition for Reduction/Waiver, as set forth on Form 3. The Petition for Reduction/Waiver shall be supported by sufficient evidence and documentation to demonstrate the Bidder or Proposer's Good Faith Efforts in attempting to achieve the applicable MBE and WBE goals, and its inability to do so despite its Good Faith Efforts.

The recommended goal is 24% Minority-owned Business Enterprise (MBE) and 10% Women-owned Business Enterprise (WBE). The 35% Disadvantaged Business Enterprise (DBE) goal is optional.

Cook County's Contract and Compliance link to the Utilization Plan, Letter of Intent (LOI) and Petition for Partial or Full Reduction of Participation forms are as follows:

<https://www.cookcountyil.gov/service/contract-documents>

**REQUIRED  
CERTIFICATIONS**

Opportunity Certification Excerpt From 41 CFR §60-1.4(b)

Office of Housing Federal Housing Commissioner

OMB Control No. 2502-0029 (exp. 9/30/2016)

The applicant hereby agrees that it will incorporate or cause to be incorporated into any contract for construction work, or modification thereof, as defined in the regulations of the Secretary of Labor at 41 CFR Chapter 60, which is paid for in whole or in part with funds obtained from the Federal Government or borrowed on the credit of the Federal Government pursuant to a grant, contract, loan insurance, or guarantee, or undertaken pursuant to any Federal program involving such grant, contract, loan, insurance, or guarantee, the following equal opportunity clause:

During the performance of this contract, the contractor agrees as follows:

- (1) The contractor will not discriminate against any employee or applicant for employment because of race, color, religion, sex, or national origin. The contractor will take affirmative action to ensure that applicants are employed, and that employees are treated during employment without regard to their race, color, religion, sex, or national origin, such action shall include, but not be limited to the following: Employment, upgrading, demotion, or transfer; recruitment or recruitment advertising; layoff or termination; rates of pay or other forms of compensation; and selection for training, including apprenticeship. The contractor agrees to post in conspicuous places, available to employees and applicants for employment, notices to be provided setting forth the provisions of this nondiscrimination clause.
(2) The contractor will, in all solicitations or advertisements for employees placed by or on behalf of the contractor, state that all qualified applicants will receive considerations for employment without regard to race, color, religion, sex, or national origin.
(3) The contractor will send to each labor union or representative of workers with which it has a collective bargaining agreement or other contract or understanding, a notice to be provided advising the said labor union or workers' representatives of the contractor's commitments under this section, and shall post copies of the notice in conspicuous places available to employees and applicants for employment.
(4) The contractor will comply with all provisions of Executive Order 11246 of September 24, 1965, and of the rules, regulations and relevant orders of the Secretary of Labor.
(5) The contractor will furnish all information and reports required by Executive Order 11246 of September 24, 1965, and by rules, regulations, and orders of the Secretary of Labor, or pursuant thereto, and will permit access to its books, records, and accounts by the administering agency and the Secretary of Labor for purposes of investigation to ascertain compliance with such rules, regulations, and orders.

- (6) In the event of the contractor's noncompliance with the nondiscrimination clauses of this contract or with any of the said rules, regulations, or orders, this contract may be canceled, terminated, or suspended in whole or in part and the contractor may be declared ineligible for further Government contracts or federally assisted construction contracts in accordance with procedures authorized in Executive Order 11246 of September 24, 1965, and such other sanctions may be imposed and remedies invoked as provided in Executive Order 11246 of September 24, 1965, or by rule, regulation, or order of the Secretary of Labor, or as otherwise provided by law.
(7) The contractor will include the portion of the sentence immediately preceding paragraph (1) and the provisions of paragraphs (1) through (7) in every subcontract or purchase order unless exempted by rules, regulations, or orders of the Secretary of Labor issued pursuant to section 204 of Executive Order 11246 of September 24, 1965, so that such provisions will be binding upon each subcontractor or vendor. The contractor will take such action with respect to any subcontract or purchase order as the administering agency may direct as a means of enforcing such provisions, including sanctions for noncompliance: Provided, however, That in the event a contractor becomes involved in, or is threatened with, litigation with a subcontractor or vendor as a result of such direction by the administering agency the contractor may request the United States to enter into such litigation to protect the interests of the United States.

The applicant further agrees that it will be bound by the above equal opportunity clause with respect to its own employment practices when it participates in federally assisted construction work:

Provided, That if the applicant so participating is a State or local government, the above equal opportunity clause is not applicable to any agency, instrumentality or subdivision of such government which does not participate in work on or under the contract.

The applicant agrees that it will assist and cooperate actively with the administering agency and the Secretary of Labor in obtaining the compliance of contractors and subcontractors with the equal opportunity clause and the rules, regulations, and relevant orders of the Secretary of Labor, that it will furnish the administering agency and the Secretary of Labor such information as they may require for the supervision of such compliance, and that it will otherwise assist the administering agency in the discharge of the agency's primary responsibility for securing compliance.

The applicant further agrees that it will refrain from entering into any contract or contract modification subject to Executive Order 11246 of September 24, 1965, with a contractor debarred from, or who has not demonstrated eligibility for, Government contracts and Federally-assisted construction contracts pursuant to the Executive order and will carry out such sanctions and penalties for violation of the equal opportunity clause as may be imposed

upon contractors and subcontractors by the administering agency or the Secretary of Labor pursuant to Part II, Subpart D of the Executive order. In addition, the applicant agrees that if it fails or refuses to comply with these undertakings, the administering agency may take any or all of the following actions: Cancel, terminate, or suspend in whole or in part this grant (contract, loan, insurance, guarantee); refrain from extending any further assistance to the applicant under the program with respect to which the failure or refund occurred until satisfactory assurance of future compliance has been received from such applicant; and refer the case to the Department of Justice for appropriate legal proceedings.

### Excerpt from HUD Regulations

#### 200.410 Definition of term "applicant".

- (a) In multifamily housing transactions where controls over the mortgagor are exercised by the Commissioner either through the ownership of corporate stock or under the provisions of a regulatory agreement, the term "applicant" as used in this subpart shall mean the mortgagor.
- (b) In transactions other than those specified in paragraph(a) of this section, the term "applicant" as used in this subpart shall mean the builder, dealer or contractor performing the construction, repair or rehabilitation work for the mortgagor or other borrower.

#### 200.420 Equal Opportunity Clause to be included in contracts and subcontracts.

- (a) The following equal opportunity clause shall be included in each contract and subcontract which is not exempt:

During the performance of this contract, the contractor agrees as follows:

- (1) The contractor will not discriminate against any employee or applicant for employment because of race, creed, color, or national origin. The contractor will take affirmative action to ensure that applicants are employed, and that employees are treated during employment without regard to their race, creed, color, or national origin. Such action shall include, but not be limited to the following: employment, upgrading, demotion or transfer; recruitment or recruitment advertising; layoff or termination; rates of pay or other forms of compensation; and selection for training, including apprenticeship. The contractor agrees to post in conspicuous places, available to employees and applicants for employment, notices to be provided setting forth the provisions of the nondiscrimination clause.

- (2) The contractor will in all solicitations or advertisements for employees placed by or on behalf of the contractor, state that all qualified applicants will receive consideration for employment without regard race, creed, color, or national origin.

- (3) The contractor will send to each labor union or representative of workers with which he has a collective bargaining agreement or other contract or understanding, a notice, to be provided, advising the said labor union or workers' representative of the contractor's commitments under this section, and shall post copies of the notices in conspicuous places available to employees and applicants for employment.

- (4) The contractor will comply with all provisions of Executive Order 10925 of March 6 1961, as amended, and of the regulations, and relevant orders of the President's Committee on Equal Employment Opportunity created thereby.

- (5) The contractor will furnish all information and reports required by Executive Order 10925 of March 6, 1961, as amended, and by the regulations, and orders of the said Committee, or pursuant thereto, and will permit access to his books, records, and accounts by HUD and the Committee for purposes of investigation to ascertain compliance with such regulations, and orders.

- (6) In the event of the contractor's non-compliance with the nondiscrimination clause of this contract or with any of the said regulations, or orders, this contract may be cancelled, terminated or suspended in whole or in part and the contractor may be declared ineligible for further Government contracts or Federally-assisted construction contracts in accordance with procedures authorized in Executive Order 10925 of March 6, 1961, as amended, and such other sanctions may be imposed and remedies invoked provided in the said Executive Order or by regulations, or order of the President's Committee on Equal Employment Opportunity, or as otherwise provided by law.

- (7) The contractor will include the provisions of Paragraphs(1) through (7) in every subcontract or purchase order unless exempted by regulations, or orders of the President's Committee on Equal Employment Opportunity issued pursuant to Section 303 of Executive Order 10925 of March 6, 1961, as amended, so that such provisions will be binding upon each subcontractor or vendor. The contractor will take such action with respect to any subcontract or purchase orders as HUD may direct as a means of enforcing such provisions, including sanctions for noncompliance: Provided, however, that in the event the contractor becomes involved in, or is threatened with, litigation with a subcontractor or vendor as a result of such direction by HUD, the contractor may request the United States to enter into such litigation to protect the interests of the United States.

- (b) Except in subcontracts for the performance of construction work at the site of construction, the clause is not required to be inserted in subcontracts below the second tier. Subcontracts may incorporate by reference to the equal opportunity clause.

#### 200.425 Modification in and exemptions from the regulations in this subpart.

- (a) The following transactions and contracts are exempt from the regulations in this subpart:

- (1) Loans, mortgages, contracts and subcontracts not exceeding \$10,000.

- (2) Contract and subcontracts not exceeding \$100,000 for standard commercial supplies or raw material;

- (3) Contracts and subcontracts under which work is to be or has been performed outside the United States and where no recruitment of workers within the United States is involved. To the extent that work pursuant to such contracts is done within the United States, the equal opportunity clause shall be applicable;

- (4) Contracts for the sale of Government property where no appreciable amount of work is involved; and

- (5) Contracts and subcontracts for an indefinite quantity which are not to extend for more than one year if the purchaser determines that the amounts to be ordered under any such contract or subcontract are not reasonably expected to exceed \$100,000 in the case of contracts or subcontracts for standard commercial supplies and raw materials, or \$10,000 in the case of all other contracts and subcontracts.

**U.S. DEPARTMENT OF HOUSING AND URBAN DEVELOPMENT**

**CERTIFICATION OF BIDDER REGARDING  
EQUAL EMPLOYMENT OPPORTUNITY**

**INSTRUCTIONS**

This certification is required pursuant to Executive Order 11246 (30 F.R. 12319-25). The implementing rules and regulations provide that any bidder or prospective contractor, or any of their proposed subcontractors, shall state as an initial part of the bid or negotiations of the contract, whether it has participated in any previous contract or subcontract subject to the equal opportunity clause; and, if so, whether it has files all compliance reports due under applicable instructions.

Where the certification indicates that the bidder has not filed a compliance report due under applicable instructions, such bidders shall be required to submit a compliance report within seven (7) calendar days after bid opening. No contract shall be awarded unless such report is submitted.

**CERTIFICATION BY BIDDER**

Bidder's Name: \_\_\_\_\_

Address and Zip Code: \_\_\_\_\_  
\_\_\_\_\_

1. Bidder has participated in previous contract or subcontract subject to the Equal Employment Opportunity Clause.  
Yes  No  (If answer is yes, identify the most recent contract)
2. Compliance reports were required to be filed in connection with such contract or subcontract.  
Yes  No  (If answer is yes, identify the most recent contract)
3. Bidder has filed all compliance reports due under applicable instructions, including SF-100.  
Yes  No  None Required
4. If answer to Item 3 is "No", please explain in detail on the reverse side of this certification.

\_\_\_\_\_  
Certification – The information above is true and complete to the best of my knowledge and belief.

\_\_\_\_\_  
(Name and Title of Signer – please type)

\_\_\_\_\_  
Signature

\_\_\_\_\_  
Date

# Certification Regarding Debarment and Suspension

## Certification A: Certification Regarding Debarment, Suspension, and Other Responsibility Matters - Primary Covered Transactions

1. The prospective primary participant certifies to the best of its knowledge and belief that its principals;

a. Are not presently debarred, suspended, proposed for debarment, declared ineligible, or voluntarily excluded from covered transactions by any Federal debarment or agency;

b. Have not within a three-year period preceding this proposal, been convicted of or had a civil judgment rendered against them for commission of fraud or a criminal offense in connection with obtaining, attempting to obtain, or performing a public (Federal, State, or local) transaction or contract under a public transaction; violation of Federal or State antitrust statutes or commission of embezzlement, theft, forgery, bribery, falsification, or destruction of records, making false statements, or receiving stolen property;

c. Are not presently indicted for or otherwise criminally or civilly charged by a governmental entity (Federal, State, or local) with commission of any of the offenses enumerated in paragraph (1)(b) of this certification; and

d. Have not within a three-year period preceding this application/proposal had one or more public transactions (Federal, State, or local) terminated for cause or default.

2. Where the prospective primary participant is unable to certify to any of the statements in this certification, such prospective participant shall attach an explanation to this proposal.

### Instructions for Certification (A)

1. By signing and submitting this proposal, the prospective primary participant is providing the certification set out below.

2. The inability of a person to provide the certification required below will not necessarily result in denial of participation in this covered transaction. The prospective participant shall submit an explanation of why it cannot provide the certification set out below. The certification or explanation will be considered in connection with the department or agency's determination whether to enter into this transaction. However, failure of the prospective primary participant to furnish a certification or an explanation shall disqualify such person from participation in this transaction.

3. The certification in this clause is a material representation of fact upon which reliance was placed when the department or agency determined to enter into this transaction. If it is later determined that the prospective primary participant knowingly rendered an erroneous certification, in addition to other remedies available to the Federal Government, the department or agency may terminate this transaction for cause of default.

4. The prospective primary participant shall provide immediate written notice to the department or agency to whom this proposal is submitted if at any time the prospective primary participant learns that its certification was erroneous when submitted or has become erroneous by reason of changed circumstances.

5. The terms **covered transaction, debarred, suspended, ineligible, lower tier covered transaction, participant, person, primary covered transaction, principal, proposal, and voluntarily excluded**, as used in this clause, have the meanings set out in the Definitions and Coverage sections of the rules implementing Executive Order 12549. You may contact the department or agency to which this proposal is being submitted for assistance in obtaining a copy of these regulations.

6. The prospective primary participant agrees by submitting this proposal that, should the proposed covered transaction be entered into, it shall not knowingly enter into any lower tier covered transaction with a person who is debarred, suspended, declared ineligible, or voluntarily excluded from participation in this covered transaction, unless authorized by the department or agency entering into this transaction.

7. The prospective primary participant further agrees by submitting this proposal that it will include the clause titled "Certification Regarding Debarment, Suspension, Ineligibility and Voluntary Exclusion - Lower Tier Covered Transaction," provided by the department or agency entering into this covered transaction, without modification, in all lower tier covered transactions and in all solicitations for lower tier covered transactions.

8. A participant in a covered transaction may rely upon a certification of a prospective participant in a lower tier covered transaction that it is not debarred, suspended, ineligible, or voluntarily excluded from the covered transaction, unless it knows that the certification is erroneous. A participant may decide the method and frequency by which it determines this eligibility of its principals. Each participant may, but is not required to, check the Nonprocurement List.

9. Nothing contained in the foregoing shall be construed to require establishment of a system of records in order to render in good faith the certification required by this clause. The knowledge and information of a participant is not required to exceed that which is normally possessed by a prudent person in the ordinary course of business dealings.

10. Except for transactions authorized under paragraph (6) of these instructions, if a participant in a covered transaction knowingly enters into a lower tier covered transaction with a person who is suspended, debarred, ineligible, or voluntarily excluded from participation in this transaction, in addition to other remedies available to the Federal Government, the department or agency may terminate this transaction for cause of default.

**Certification B: Certification Regarding Debarment, Suspension, Ineligibility and Voluntary Exclusion - Lower Tier Covered Transactions**

1. The prospective lower tier participant certifies, by submission of this proposal, that neither it nor its principals is presently debarred, suspended, proposed for debarment, declared ineligible, or voluntarily excluded from participation in this transaction by any Federal department or agency.

2. Where the prospective lower tier participant is unable to certify to any of the statements in this certification, such prospective participant shall attach an explanation to this proposal.

**Instructions for Certification (B)**

1. By signing and submitting this proposal, the prospective lower tier participant is providing the certification set out below.

2. The certification in this clause is a material representation of fact upon which reliance was placed when this transaction was entered into. If it is later determined that the prospective lower tier participant knowingly rendered an erroneous certification, in addition to other remedies available to the Federal Government, the department or agency with which this transaction originated may pursue available remedies, including suspension and/or debarment.

3. The prospective lower tier participant shall provide immediate written notice to the person to which this proposal is submitted if at any time the prospective lower tier participant learns that its certification was erroneous when submitted or has become erroneous by reason of changed circumstances.

4. The terms **covered transaction, debarred, suspended, ineligible, lower tier covered transaction, participant, person, primary covered transaction, principal, proposal, and voluntarily excluded**, as used in this clause, have the meanings set out in the Definitions and Coverage sections of rules implementing Executive Order 12549. You may contact the person to which this proposal is submitted for assistance in obtaining a copy of these regulations.

5. The prospective lower tier participant agrees by submitting this proposal that, should the proposed covered transaction be entered into, it shall not knowingly enter into any lower tier covered transaction with a person who is debarred, suspended, declared ineligible, or voluntarily excluded from participation in this covered transaction, unless authorized by the department or agency with which this transaction originated.

6. The prospective lower tier participant further agrees by submitting this proposal that it will include this clause titled "Certification Regarding Debarment, Suspension, Ineligibility and Voluntary Exclusion - Lower Tier Covered Transaction," without modification, in all lower tier covered transactions and in all solicitations for lower tier covered transactions.

7. A participant in a covered transaction may rely upon a certification of a prospective participant in a lower tier covered transaction that it is not debarred, suspended, ineligible, or voluntarily excluded from the covered transaction, unless it knows that the certification is erroneous. A participant may decide the method and frequency by which it determines the eligibility of its principals. Each participant may, but is not required to, check the Nonprocurement List.

8. Nothing contained in the foregoing shall be construed to require establishment of a system of records in order to render in good faith the certification required by this clause. The knowledge and information of a participant is not required to exceed that which is normally possessed by a prudent person in the ordinary course of business dealings.

9. Except for transactions authorized under paragraph (5) of these instructions, if a participant in a lower covered transaction knowingly enters into a lower tier covered transaction with a person who is suspended, debarred, ineligible, or voluntarily excluded from participation in this transaction, in addition to other remedies available to the Federal Government, the department or agency with which this transaction originated may pursue available remedies including suspension and/or debarment.

Applicant		Date
Signature of Authorized Certifying Official	Title	



---

## CERTIFICATION REGARDING LOBBYING

### Certification for Contracts, Grants, Loans, and Cooperative Agreements

The undersigned certifies, to the best of his or her knowledge and belief, that:

(1) No Federal appropriated funds have been paid or will be paid, by or on behalf of the undersigned, to any person for influencing or attempting to influence an officer or employee of an agency, a Member of Congress, an officer or employee of Congress, or an employee of a Member of Congress in connection with the awarding of any Federal contract, the making of any Federal grant, the making of any Federal loan, the entering into of any cooperative agreement, and the extension, continuation, renewal, amendment, or modification of any Federal contract, grant, loan, or cooperative agreement.

(2) If any funds other than Federal appropriated funds have been paid or will be paid to any person for influencing or attempting to influence an officer or employee of any agency, a Member of Congress, an officer or employee of Congress, or an employee of a Member of Congress in connection with this Federal contract, grant, loan, or cooperative agreement, the undersigned shall complete and submit Standard Form-LLL, "Disclosure of Lobbying Activities," in accordance with its instructions.

(3) The undersigned shall require that the language of this certification be included in the award documents for all subawards at all tiers (including subcontracts, subgrants, and contracts under grants, loans, and cooperative agreements) and that all subrecipients shall certify and disclose accordingly. This certification is a material representation of fact upon which reliance was placed when this transaction was made or entered into. Submission of this certification is a prerequisite for making or entering into this transaction imposed by section 1352, title 31, U.S. Code. Any person who fails to file the required certification shall be subject to a civil penalty of not less than \$10,000 and not more than \$100,000 for each such failure.

### Statement for Loan Guarantees and Loan Insurance

The undersigned states, to the best of his or her knowledge and belief, that:

If any funds have been paid or will be paid to any person for influencing or attempting to influence an officer or employee of any agency, a Member of Congress, an officer or employee of Congress, or an employee of a Member of Congress in connection with this commitment providing for the United States to insure or guarantee a loan, the undersigned shall complete and submit Standard Form-LLL, "Disclosure of Lobbying Activities," in accordance with its instructions. Submission of this statement is a prerequisite for making or entering into this transaction imposed by section 1352, title 31, U.S. Code. Any person who fails to file the required statement shall be subject to a civil penalty of not less than \$10,000 and not more than \$100,000 for each such failure.

\* APPLICANT'S ORGANIZATION

\* PRINTED NAME AND TITLE OF AUTHORIZED REPRESENTATIVE

Prefix:  \* First Name:  Middle Name:

\* Last Name:  Suffix:

\* Title:

\* SIGNATURE:

\* DATE:

---

**APPENDIX B**  
**(Capital Davis Bacon Construction Packet)**



**COOK COUNTY**  
**DEPARTMENT OF PLANNING AND**  
**DEVELOPMENT**



Community Development Block Grant Program

**DAVIS-BACON**  
**CONSTRUCTION PACKET**

DAVIS-BACON FORMS FOR CONTRACTORS &  
SUBCONTRACTORS WITH CONTRACTS OVER \$2,000

- (1) CONTRACTOR AFFIRMATIVE ACTION PLAN
- (2) CONTRACTOR & SUBCONTRACTOR CERTIFICATIONS
- (3) CONTRACT & SUBCONTRACT ACTIVITY FORM (HUD-2516)  
*(This document may be required prior to construction completion.)*
- (4) WEEKLY PAYROLL & STATEMENT OF COMPLIANCE  
*(A completed "Certified Payroll Review Form" must be attached to each payroll submitted.)*
- (5) RECORD OF EMPLOYEE INTERVIEW FORM ( HUD-11)  
*(During the course of construction, each required interview must be completed by the Subrecipient or their designated representative.)*

**All required CDBG Davis-Bacon documentation and certifications are to be completed and submitted to the Subrecipient or their designated Representative (Engineer, Consultant, Architect, etc.), prior to project and construction completion. No funds will be disbursed until all required documentation is approved.**



**COOK COUNTY GOVERNMENT  
COMMUNITY DEVELOPMENT BLOCK GRANT PROGRAM**

**CONTRACTOR'S CERTIFICATION  
CONCERNING LABOR STANDARDS AND PREVAILING WAGE REQUIREMENTS**

To:	Date
	CDBG Project Number
Project Name:	

1. The undersigned, having executed a contract with \_\_\_\_\_ for the construction of the above identified project, acknowledges that:
  - (a) The Labor Standards provisions are included in the aforesaid contract;
  - (b) Correction of any infractions of the aforesaid conditions, including infractions by any of his subcontractors and any lower tier subcontractors, is his responsibility.
  
2. He/She certifies that:
  - (a) Neither he nor any firm, partnership or association in which he/she has substantial interest is designated as an ineligible contractor by the Comptroller General of the United States pursuant to Section 5.6(b) of the Regulations of the Secretary of Labor, Part 5 (29 CFR, Part 5) or pursuant to Section 3a) of the Davis-Bacon Act, as amended ((40 U.S.C. 276-2(a)).
  - (b) No part of the aforementioned contract has been or will be subcontracted to any subcontractor if such subcontractor or any firm, corporation, partnership or association in which such subcontractor has a substantial interest is designated as an ineligible contractor pursuant to any of the aforementioned regulatory or statutory provisions.
  
3. He/She agrees to obtain and forward to the aforementioned recipient within ten days after the execution of any subcontract, including those executed by his/her subcontractors and any lower tier subcontractors, a Subcontractor's Certification Concerning Labor Standards and Prevailing Wage Requirements executed by the subcontractors.
  
4. He/She certifies that:
  - (a) The legal name and the business address of the undersigned are:

Name	
Business Address	

- (b) The undersigned is:
  - (1) A SINGLE PROPRIETORSHIP
  - (2) A PARTNERSHIP
  - (3) A CORPORATION ORGANIZED IN THE STATE OF \_\_\_\_\_
  - (4) OTHER ORGANIZATION (*Describe*) \_\_\_\_\_
  
- (c) The name, title and address of the owner, partners or officers of the undersigned are:

NAME	TITLE	ADDRESS

(d) The names and addresses of all other persons, both natural and corporate, having a substantial interest in the undersigned and the nature of the interest are *(If none, so state)*:

NAME	TITLE	NATURE OF INTEREST

(e) The names, addresses and trade classifications of all other building contractors in which the undersigned has a substantial interest are *(If none, so state)*:

NAME	TITLE	TRADE OF CLASSIFICATION

\_\_\_\_\_  
(Contractor)

By: \_\_\_\_\_

By: \_\_\_\_\_

**WARNING**

U.S. Criminal Code Section 1010, Title 18 U.S.C., provides in part: "Whoever... makes, passes, utters, or publishes any statement, knowing the same to be false... shall be fined not more than \$5,000 or imprisoned not more than two years, or both."

---

COOK COUNTY GOVERNMENT  
COMMUNITY DEVELOPMENT BLOCK GRANT PROGRAM  
**SUBCONTRACTOR'S CERTIFICATION**  
CONCERNING LABOR STANDARDS AND PREVAILING WAGE REQUIREMENTS

---

DATE: \_\_\_\_\_

---

CDBG PROJECT NUMBER

PROJECT NAME

1. The undersigned, having executed a contract with \_\_\_\_\_  
*(Contractor or Subcontractor)*  
\_\_\_\_\_ for \_\_\_\_\_  
*(Name of Work)*  
\_\_\_\_\_ In the amount of \$ \_\_\_\_\_

In the construction of the above-identified project, certifies that:

- (a) The Labor Standards Provisions of The Contract for Construction are included in the aforesaid contract.
- (b) Neither he nor any firm, corporation, partnership or association in which he has a substantial interest is designated as an ineligible contractor by the Comptroller General of the United States pursuant to Section 5.6(b) of the Regulations of the Secretary of Labor, Part 5 (29 CFR, Part 5), or pursuant to Section 3(a) of the Davis-Bacon Act, as amended (40 U.S.C. 276a02 (a)).
- (c) No part of the aforementioned contract has been or will be subcontracted to any subcontractor if such subcontractor or any firm, corporation, partnership or association in which such subcontractor has a substantial interest is designated as an ineligible contractor pursuant to the aforesaid regulatory or statutory provisions.

2. He agrees to obtain and forward to the contractor, for transmittal to the recipient, within ten days after the execution of any lower subcontract, a Subcontractor's Certification Concerning Labor Standards and Prevailing Wage Requirements, executed by the lower tier subcontractor, in duplicate.

(a) The workmen will report for duty on or about \_\_\_\_\_  
*(Date)*

3. He certifies that:

- (a) The legal name and the business address of the undersigned are:  
\_\_\_\_\_  
\_\_\_\_\_
- (b) The undersigned is:  
(1) A SINGLE PROPRIETORSHIP: \_\_\_\_\_ (3) A CORPORATION ORGANIZED IN THE STATE OF: \_\_\_\_\_  
\_\_\_\_\_  
(2) A PARTNERSHIP: \_\_\_\_\_ (4) OTHER ORGANIZATION (Describe) \_\_\_\_\_  
\_\_\_\_\_

(c) The name, title and address of the owner, partners or officers of the undersigned are:  
NAME TITLE ADDRESS

\_\_\_\_\_  
\_\_\_\_\_  
\_\_\_\_\_  
\_\_\_\_\_

(d) The names and addresses of all other persons, both natural and corporate, having a substantial interest in the undersigned, and the nature of the interest are <i>(If none, so state)</i> :		
NAME	ADDRESS	NATURE OF INTEREST

(e) The names, addresses and trade classifications of all other building construction contractors in which the undersigned has a substantial interest are <i>(If none, so state)</i> :		
NAME	ADDRESS	TRADE CLASSIFICATION

\_\_\_\_\_

*(Subcontractor)*

\_\_\_\_\_

*(Signature)*

\_\_\_\_\_

*(Typed Name and Title)*

**WARNING**

U.S. Criminal Code, Section 1010, Title 18, U.S.C., provides in part: "Whoever.....makes, passes, utters, or publishes any statement, knowing the same to be false.....shall be fined not more than \$5,000 or imprisoned not more than two years, or both."



## Instructions for HUD Form 2516

This report is to be completed by grantees, developers, sponsors, builders, agencies, and/or project owners for reporting contract and subcontract activities of \$10,000 or more under the following programs:

Community Development Block Grants (entitlement and small cities); Urban Development Action Grants; Housing Development Grants; Multifamily Insured and Noninsured; Public and Indian Housing Authorities; and contracts entered into by recipients of CDBG rehabilitation assistance.

Contracts/subcontracts of less than \$10,000 need be reported only if such contracts represent a significant portion of your total contracting activity. Include only contracts executed during this reporting period.

This form has been modified to capture Section 3 contract data in columns 7g and 7i. Section 3 requires that the employment and other economic opportunities generated by HUD financial assistance for housing and community development programs shall, to the greatest extent feasible, be directed toward low- and very low-income persons, particularly those who are recipients of government assistance for housing. Recipients using this form to report Section 3 contract data must also use Part I of form HUD-60002 to report employment and training opportunities data. Form HUD-2516 is to be completed for public and Indian housing and most community development programs. Form HUD-60002 is to be completed by all other HUD programs including State administered community development programs covered under Section 3. A Section 3 Contractor/subcontractor is a business concern that provides economic opportunities to low and very low-income residents of the metropolitan area (or non-metropolitan county), including a business concern that is 51% or more owned by low-income residents; or provides subcontracting or business development opportunities to businesses owned by low or low-income residents. Low and very low-income residents; include participants in Youth build programs established under Subtitle D of Title IV of the Cranston-Gonzalez National Affordable Housing Act.

The terms “low-income persons” and “very low-income persons” have the same meanings given the terms in section 3(b)(2) of the United States Housing Act of 1937. Low-income persons mean families (including single persons) whose incomes do not exceed 80% of the median income for the area, as determined by the Secretary, with adjustments for smaller and larger families, except that the Secretary may establish income ceilings higher or lower than 80% of the median for the area on the basis of the Secretary's findings that such variations are necessary because of prevailing levels of construction costs or unusually high or low-income families. Very low-income families (including single persons) whose incomes do not exceed 50% of the median family income for the area, as determined by the Secretary with adjustments for smaller and larger families, except that the secretary may establish income ceilings higher or lower than 50% of the median for the area on the basis of the Secretary's findings that such variations are necessary because of unusually high or low family incomes.

Submit two (2) copies of this report to your local HUD Office within ten (10) days after the end of the reporting period you checked in item 4 on the front. Complete item 7h. Only once for each contractor/subcontractor on each semi-annual report.

Enter the prime contractor's ID in item 7f for all contracts and subcontracts. Include only contracts expected during this reporting period. PHAs/IHAs are to report all contracts/subcontracts.

## Instructions for HUD Form 2516, continued

---

### Community Development Programs

**1. Grantee:** Enter the name of the unit of government submitting this report.

**3. Contact Person:** Enter name and phone of person responsible for maintaining and submitting contract/subcontract data.

**7a. Grant Number:** Enter the HUD Community Development Block Grant Identification Number (with dashes). For example: B-32-MC-25-0034. For Entitlement Programs and Small City multi-year comprehensive programs, enter the latest approved grant number.

**7b. Amount of Contract/Subcontract:** Enter the dollar amount rounded to the nearest dollar. If subcontractor ID number is provided in 7f, the dollar figure would be for the subcontract only and not for the prime contract.

**7c. Type of Trade:** Enter the numeric codes which best indicates the contractor's/subcontractor's service. If subcontractor ID number is provided in 7f., the type of trade code would be for the subcontractor only and not for the prime contractor.

The "other" category includes supply, professional services and all other activities except construction and education/training activities.

**7d. Business Racial/Ethnic/Gender Code:** Enter the numeric code which indicates the racial/ethnic/gender character of the owner(s) and controller(s) of 51% of the business.

When 51% or more is not owned and controlled by any single racial/ethnic/gender category, enter the code which seems most appropriate. If the subcontractor ID number is provided, the code would apply to the subcontractor and not to the prime contractor.

**7e. Woman Owned Business:** Enter Yes or No.

**7f. Contractor Identification (ID) Number:** Enter the Employer (IRS) Number of the Prime Contractor as the unique identifier for prime recipient of HUD funds. Note that the Employer (IRS) Number must be provided for each contract/subcontract awarded.

**7g. Section 3 Contractor:** Enter Yes or No.

**7h. Subcontractor Identification (ID) Number:** Enter the Employer (IRS) Number of the subcontractor as the unique identifier for each subcontract awarded from HUD funds. When the subcontractor ID Number is provided, the respective Prime Contractor ID Number must also be provided.

**7i. Section 3 Contractor:** Enter Yes or No.

**7j. Contractor/Subcontractor Name and Address:** Enter this information for each firm receiving contract/subcontract activity only one time on each report for each firm.

Public reporting burden for this collection of information is estimated to average .5 hours per response, including the time for reviewing instructions, searching existing data sources, gathering and maintaining the data needed, and completing and reviewing the collection of information. The information is voluntary. HUD may not collect this information, and you are not required to complete this form, unless it displays a currently valid OMB Control Number.

Executive Orders dated July 14, 1983, directs the Minority Business Development Plans shall be developed by each Federal Agency and the these annual plans shall establish minority business development objectives. The information is used by HUD to monitor and evaluate MBE activities against the total program activity and the designated minority business enterprise (MBE) goals. The Department requires the information to provide guidance and oversight for programs for the development of minority business enterprise concerning Minority Business Development. If the information is not collected HUD would not be able to establish meaningful MBE goals nor evaluate MBE performance against these goals.

**Privacy Act Notice** = The United States Department of Housing and Urban Development, Federal Housing Administration, is authorized to solicit the Information requested in this form by virtue of Title 12, United States Code, Section 1701 et seq., and regulation. It will not be disclosed or released outside the United States Department of Housing and Urban Development without your consent, except as required or permitted by Law.

1. Grantee/Project Owner/Developer/Sponsor/Builder/Agency	Check if:	2. Location (City, State Zip Code)
	PH	
	IH	
	CPD	
	Housing	S

3a. Name of Contact Person	3b. Phone Number (Including Area Code)	4. Reporting Period <input type="checkbox"/> Oct. 1 - Sept. 30 (Annual -FY)	5. Program Code (Not applicable for CPD programs.) See explanation of Codes at bottom of Page Use a separate sheet for each program code.	6. Date Submitted to Field Office
----------------------------	--	--	--	-----------------------------------

Grant/Project Number or HUD Case Number or other identification of property, subdivision, dwelling unit, etc. 7a.	Amount of Contract or Subcontract 7b.	Type of Trade Code (See below) 7c.	Contractor or Subcontractor Business Racial/Ethnic (See below) 7d.	Woman Owned Business (Yes or No) 7e.	Prime Contractor Identification (ID) Number 7f.	Sec. 3 7g.	Subcontractor Identification (ID) Number 7h.	Sec. 3 7i.	Contractor/Subcontractor Name and Address 7j.										
						Name					Street	City	State	Zip					

<b>CPD:</b>	<b>7c: Type of Trade Codes:</b>	<b>7d: Racial/Ethnic Codes:</b>	<b>5: Program Codes (Complete for Housing and Public and Indian Housing programs only):</b>
1 = New Construction	1 = New Construction	1 = White Americans	1 = All Insured, including Section 8
2 = Education/Training	2 = Substantial Rehab.	2 = Black Americans	2 = Flexible Subsidy
3 = Other	3 = Repair	3 = Native Americans	3 = Section 8 Noninsured, Non-HFDA
	4 = Service	4 = Hispanic Americans	4 = Insured (Management)
	5 = Project Mangt.	5 = Asian/Pacific Americans	
	6 = Professional	6 = Hasidic Jews	
	7 = Tenant Services		
	8 = Education/Training		
	9 = Arch./Engng. Appraisal		
	0 = Other		

Previous editions are obsolete. form HUD-2516 (8/98)

## **MAKE CERTAIN ALL PAYROLLS CONTAIN THE FOLLOWING:**

1. Manual signature on back of payroll.
2. Statement of Compliance completed on back of payroll.
3. Appropriate block is checked regarding payment of fringe benefits.
4. Show a breakdown on trades in remarks on back of payroll, base rate and fringe benefits.
5. Payrolls are numbered. First payroll is No. 1 and continue. Mark last payroll "FINAL" and numbered.
6. Days and dates appear under Item 4.
7. Subcontractor's name and address on top of line.
8. Project number (upper right hand corner), name and location.
9. Workman's address and social security number appears on the first payroll on which the name appears.
10. Fill in Classification in No. 3 and include Class, Type, Size, etc. of power equipment operated.
11. Note in column 3 if workman is an apprentice, and furnish proof to HUD-FHA.
12. Make sure net wages, gross wages and deductions are shown.
13. The new "Certified Payroll Review Form" must be completed and attached to each payroll. The payroll number, week ending and reviewers signature is required.

## **NOTE: INCOMPLETE PAYROLLS ARE UNACCEPTABLE!**

### Contractors Payroll checklist

1. Make certain all item in the heading are completed, including payroll number and project number. Also review reverse side of Form to make certain proper block is checked and signature is affixed.

2. Specify the name, full address (including zip code) an social security number for each employee the first time such an employee is listed on a Payroll report. If employees with identical names are shown on payrolls, provide social security numbers on each payroll to distinguish these employees.

If payrolls are typed, we suggest you make a “master” listing of each employee, address, city, state , zip code and social security number. Reproduce from the “master” payroll for each week ensuring each week of work is numbered sequentially. For those employees who did not work during a particular week, just draw a line though the entry by their names and write “no work.”

Except for the work ending column, the date and days worked and the payroll report number, hours worked and pay information, everything else is preprinted.

Payrolls may be completed in dark lead #2 pencil or pen, but they must be legible. Illegible payrolls which are difficult to read are unacceptable.

Payrolls must be signed in ink, they are unacceptable when signed in pencil.

3. For equipment operators and truck drivers, include a brief but clear description of the equipment the employee is operating. (This is to be shown on each payroll report.)
4. Show the hours and wages actually worked on the subject project separate from the employees total wages for the week. To illustrate: “Joe Doe” (see Example 4) worked on the project 18 hours and on other projects for the same contactor 22 hours. (18 x \$6.45 = \$116.10 earned this project \$239.30 gross amount earned all projects). Circle hours, rate and gross amount on HUD job. State on the bottom of the first Payroll report that “circled hours represent hours worked on HUD job.”

The net amount shown on Payroll report must represent the check amount. If the employee is paid a separate check for work performed on the HUD job, it is not necessary to provide information about work or salary paid on other jobs, but the check received by the employee must agree with the amount shown on the certified payroll report.

5. Fringe Benefits: Fringe benefits (if shown on the wage determination) must be paid (in cash, to a trust, plan or fund) for each hour worked.

When fringe benefits are sent to an approved program, (trust, plan or fund) they need not be included in the rate of pay. Example 5 - Cement Mason, Mr. John Johnson, receives \$5.90 per hours, an additional \$0.66 is being sent to an approved plan – indicated by marking box (a) of paragraph (4) on the Statement of Compliance (reverse side of payroll form).

Cement Mason, Mr. Bill Thomas, receives the fringe benefits required in cash – the total rate of pay shown must be equal to the wage rate for the classification plus fringe benefits. The \$5.90 (wage rate) plus \$.066 (fringe) - \$6.56 – indicated by marking box (b) of paragraph (4) on reverse side of payroll.

6. When an individual performs work on the project in more than one classification within the same work week, have that individual sign the payroll report by his name or submit a copy of his time card with the payroll report. (If a lower rate of pay per hour is applicable).
7. When a bonified subcontractor works on the job, he/she shall be listed on the payroll as owner and show his/her daily and total hours for the week. I.M. Boss (see example 7). If the subcontractor has no employees and performs alone on the project, he/she will submit weekly payrolls showing daily and total hours worked. When two or more working owner/operators (partners, co-owners, corporation officers, etc.) perform work on the project they must show daily and total hours worked (always show exact work classification.)
8. Apprentices/Trainees: Submit an Apprenticeship or Trainee Certification with the payroll report on which apprentice or trainee if first reported. Indicate step of apprenticeship or trainee and what percentage of the journeyman wage he is receiving. (see Example 8)
9. It is the General Contractor's responsibility to submit correct payrolls. The General Contractor should therefore compare the wage rate shown on each Subcontractor's payroll with the required rate shown on the wage determination for this project. If there are underpayments, restitution should be required and the payroll report corrected prior to submitting it to the HUD office or contracting agency.

Deductions must be identified; you must specify what each deduction is for. You cannot lump-sum deductions under "other". The reviewer must ensure deductions are "authorized" such as insurance, vacation, health benefits, etc. For other deductions such as "Union Dues", Credit Unions, monetary advances, or deductions for tool purchases, employee authorization statements are required. A statement from each employee authorizing the deduction be made for a specific purpose should be filed with the HUD office or contracting agency.

10. Payroll Form: Contractors are urged to use the Department of Labor (DOL) Form WH-347, Payroll. The text of the "weekly statement with respect to the payment of wages," which is required by regulations of the Secretary of Labor, appears on the reverse side of this optional form. A contractor may use a computerized payroll document or a payroll form of his/her own choosing as long as it contains essentially the same information required on the front and back of the WH-347 Payroll Form. For example, contractors may choose to submit their own payroll form each week and fill out only the back of the WH-347 Payroll Form, or WH-348 which is the required "Statement of Compliance."
11. In the event any contractor sees he will be employing a trade for which a wage rate is not listed on the wage determination, it should be brought immediately to the attention of the contracting agency so that a wage rate determination for that trade can be made at the earliest possible date. A HUD 4230A (Optional Form) should be completed so that a rate can be established (see Example).
12. Submission of Payrolls: Each contractor or subcontractor shall submit to the contracting agency a completed payroll for each work week from the time he begins work on a project until work it is completed. All payrolls are to be numbered sequentially (starting with Number 1), and "final payrolls shall be identified accordingly. If no work is performed on the project during a given period, on the next performance payroll, state: "No work performed from pay period ending \_\_\_\_\_ through \_\_\_\_\_."
 

\_\_\_\_\_  
 (date)

\_\_\_\_\_  
 (date)
13. Payroll must be signed by an officer of the company or an individual who has been "authorized" to do so by an officer of the company.
14. Overtime: Overtime provisions for work performed over 40 hours per work week is computed at one and one-half (1 ½) times the basic rate of pay paid by the contractor. Fringe benefits are not included in the computation of overtime.

15. Additional Classifications: All laborers or mechanics need be classified in one of the listed classifications on the wage decision. If one is missing, please complete the attached HUD 4230A.

Note: The PRIME Contractor and originating SUBCONTRACTOR must maintain a copy of all documents submitted to HUD or the contracting agency. This is required.

## Wage and Hour Division (WHD)

### Instructions for Completing Payroll Form, WH-347

WH-347 (PDF)

OMB Control No. 1235-0008, Expires 01/31/2015.

General: Form WH-347 has been made available for the convenience of contractors and subcontractors required by their Federal or Federally-aided construction-type contracts and subcontracts to submit weekly payrolls. Properly filled out, this form will satisfy the requirements of Regulations, Parts 3 and 5 (29 C.F.R., Subtitle A), as to payrolls submitted in connection with contracts subject to the Davis-Bacon and related Acts.

While completion of Form WH-347 is optional, it is mandatory for covered contractors and subcontractors performing work on Federally financed or assisted construction contracts to respond to the information collection contained in 29 C.F.R. §§ 3.3, 5.5(a). The Copeland Act (40 U.S.C. § 3145) requires contractors and subcontractors performing work on Federally financed or assisted construction contracts to "furnish weekly a statement with respect to the wages paid each employee during the preceding week." U.S. Department of Labor (DOL) Regulations at 29 C.F.R. § 5.5(a)(3)(ii) require contractors to submit weekly a copy of all payrolls to the Federal agency contracting for or financing the construction project, accompanied by a signed "Statement of Compliance" indicating that the payrolls are correct, complete and each laborer or mechanic has been paid not less than the proper Davis-Bacon prevailing wage rate for the work performed. DOL and federal contracting agencies receiving this information review the information to determine that employees have received legally required wages and fringe benefits.

Under the Davis-Bacon and related Acts, the contractor is required to pay not less than prevailing wage, including fringe benefits, as predetermined by the Department of Labor. The contractor's obligation to pay fringe benefits may be met either by payment of the fringe benefits to bona fide benefit plans, funds or programs or by making payments to the covered workers (laborers and mechanics) as cash in lieu of fringe benefits.

This payroll provides for the contractor to show on the face of the payroll all monies to each worker, whether as basic rates or as cash in lieu of fringe benefits, and provides for the contractor's representation in the statement of compliance on the payroll (as shown on page 2) that he/she is paying for fringe benefits required by the contract and not paid as cash in lieu of fringe benefits.

Detailed instructions concerning the preparation of the payroll follow:

Contractor or Subcontractor: Fill in your firm's name and check appropriate box.

Address: Fill in your firm's address.

Payroll No.: Beginning with the number "1", list the payroll number for the submission.

For Week Ending: List the workweek ending date.

Project and Location: Self-explanatory.

Project or Contract No.: Self-explanatory.

Column 1 - Name and Individual Identifying Number of Worker: Enter each worker's full name and an individual identifying number (e.g., last four digits of worker's social security number) on each weekly payroll submitted.

Column 2 - No. of Withholding Exemptions: This column is merely inserted for the employer's convenience and is not a requirement of Regulations, Part 3 and 5.

Column 3 - Work Classifications: List classification descriptive of work actually performed by each laborer or mechanic. Consult classification and minimum wage schedule set forth in contract specifications. If additional classifications are deemed necessary, see Contracting Officer or Agency representative. An individual may be shown as having worked in more than one classification provided an accurate breakdown or hours worked in each classification is maintained and shown on the submitted payroll by use of separate entries.

Column 4 - Hours worked: List the day and date and straight time and overtime hours worked in the applicable boxes. On all contracts subject to the Contract Work Hours Standard Act, enter hours worked in excess of 40 hours a week as "overtime".

Column 5 - Total: Self-explanatory

Column 6 - Rate of Pay (Including Fringe Benefits): In the "straight time" box for each worker, list the actual hourly rate paid for straight time worked, plus cash paid in lieu of fringe benefits paid. When recording the straight time hourly rate, any cash paid in lieu of fringe benefits may be shown separately from the basic rate. For example, "\$12.25/.40" would reflect a \$12.25 base hourly rate plus \$0.40 for fringe benefits. This is of assistance in correctly computing overtime. See "Fringe Benefits" below. When overtime is worked, show the overtime hourly rate paid plus any cash in lieu of fringe benefits paid in the "overtime" box for each worker; otherwise, you may skip this box. See "Fringe Benefits" below. Payment of not less than time and one-half the basic or regular rate paid is required for overtime under the Contract Work Hours Standard Act of 1962 if the prime contract exceeds \$100,000. In addition to paying no less than the predetermined rate for the classification which an individual works, the contractor must pay amounts predetermined as fringe benefits in the wage decision made part of the contract to approved fringe benefit plans, funds or programs or shall pay as cash in lieu of fringe benefits. See "FRINGE BENEFITS" below.

Column 7 - Gross Amount Earned: Enter gross amount earned on this project. If part of a worker's weekly wage was earned on projects other than the project described on this payroll, enter in column 7 first the amount earned on the Federal or Federally assisted project and then the gross amount earned during the week on all projects, thus "\$163.00/\$420.00" would reflect the earnings of a worker who earned \$163.00 on a Federally assisted construction project during a week in which \$420.00 was earned on all work.

Column 8 - Deductions: Five columns are provided for showing deductions made. If more than five deductions are involved, use the first four columns and show the balance deductions under "Other" column; show actual total under "Total Deductions" column; and in the attachment to the payroll describe the deduction(s) contained in the "Other" column. All deductions must be in accordance with the provisions of the Copeland Act Regulations, 29 C.F.R., Part 3. If an individual worked on other jobs in addition to this project, show actual deductions from his/her weekly gross wage, and indicate that deductions are based on his gross wages.

Column 9 - Net Wages Paid for Week: Self-explanatory.



Totals - Space has been left at the bottom of the columns so that totals may be shown if the contractor so desires.

Statement Required by Regulations, Parts 3 and 5: While the "statement of compliance" need not be notarized, the statement (on page 2 of the payroll form) is subject to the penalties provided by 18 U.S.C. § 1001, namely, a fine, possible imprisonment of not more than 5 years, or both. Accordingly, the party signing this statement should have knowledge of the facts represented as true.

Items 1 and 2: Space has been provided between items (1) and (2) of the statement for describing any deductions made. If all deductions made are adequately described in the "Deductions" column above, state "See Deductions column in this payroll." See "FRINGE BENEFITS" below for instructions concerning filling out paragraph 4 of the statement.

Item 4 FRINGE BENEFITS - Contractors who pay all required fringe benefits: If paying all fringe benefits to approved plans, funds, or programs in amounts not less than were determined in the applicable wage decision of the Secretary of Labor, show the basic cash hourly rate and overtime rate paid to each worker on the face of the payroll and check paragraph 4(a) of the statement on page 2 of the WH-347 payroll form to indicate the payment. Note any exceptions in section 4(c).

Contractors who pay no fringe benefits: If not paying all fringe benefits to approved plans, funds, or programs in amounts of at least those that were determined in the applicable wage decision of the Secretary of Labor, pay any remaining fringe benefit amount to each laborer and mechanic and insert in the "straight time" of the "Rate of Pay" column of the payroll an amount not less than the predetermined rate for each classification plus the amount of fringe benefits determined for each classification in the application wage decision. Inasmuch as it is not necessary to pay time and a half on cash paid in lieu of fringe benefits, the overtime rate shall be not less than the sum of the basic predetermined rate, plus the half time premium on basic or regular rate, plus the required cash in lieu of fringe benefits at the straight time rate. In addition, check paragraph 4(b) of the statement on page 2 the payroll form to indicate the payment of fringe benefits in cash directly to the workers. Note any exceptions in section 4(c).

#### Use of Section 4(c), Exceptions

Any contractor who is making payment to approved plans, funds, or programs in amounts less than the wage determination requires is obliged to pay the deficiency directly to the covered worker as cash in lieu of fringe benefits. Enter any exceptions to section 4(a) or 4(b) in section 4(c). Enter in the Exception column the craft, and enter in the Explanation column the hourly amount paid each worker as cash in lieu of fringe benefits and the hourly amount paid to plans, funds, or programs as fringe benefits. The contractor must pay an amount not less than the predetermined rate plus cash in lieu of fringe benefits as shown in section 4(c) to each such individual for all hours worked (unless otherwise provided by applicable wage determination) on the Federal or Federally assisted project. Enter the rate paid and amount of cash paid in lieu of fringe benefits per hour in column 6 on the payroll. See paragraph on "Contractors who pay no fringe benefits" for computation of overtime rate.

-----

Public Burden Statement: We estimate that it will take an average of 55 minutes to complete this collection of information, including time for reviewing instructions, searching existing data sources, gathering and maintaining the data needed, and completing and reviewing the collection of information. If you have any comments regarding these estimates or any other aspect of this collection of information, including suggestions for reducing this burden, send them to the Administrator, Wage and Hour Division, ESA, U.S. Department of Labor, Room S3502, 200 Constitution Avenue, N.W., Washington, D.C. 20210.



Toni Preckwinkle  
President  
Cook County Board of Commissioners

## CERTIFIED PAYROLL REVIEW FORM

(Cook County Department of Planning and Development)

SUBRECIPIENT: \_\_\_\_\_

PROJECT NO.: \_\_\_\_\_ PROJECT TITLE: \_\_\_\_\_

CONTRACTOR: \_\_\_\_\_

SUBCONTRACTOR: \_\_\_\_\_

PAYROLL NO.: \_\_\_\_\_ WEEK ENDING: \_\_\_\_\_

*I have reviewed the Certified Payroll(s) specified above for the above referenced project.*

*Based on my review, the wages paid meets the current Federal Prevailing Wage for Cook County.*

PROJECT MANAGER: \_\_\_\_\_  
(Subrecipient/Engineer) Reviewer's Signature Date

PROJECT MANAGER: \_\_\_\_\_  
(Cook County Planner/Manager) County Signature Date

**\*This form must be completed and attached to each payroll submission.** The awarded CDBG Subrecipient or hired Engineer (Project Manager) must sign, date and return all required certified payroll review forms, along with proof of payrolls to Cook County's assigned project planner/manager prior to submitting drawdown requests.

**PAYROLL**

(For Contractor's Optional Use; See Instructions at [www.dol.gov/whd/forms/wh347instr.htm](http://www.dol.gov/whd/forms/wh347instr.htm))

Persons are not required to respond to the collection of information unless it displays a currently valid OMB control number.



OMB No.: 1215-0149  
Expires: 12/31/2011

NAME OF CONTRACTOR <input type="checkbox"/> OR SUBCONTRACTOR <input type="checkbox"/>	ADDRESS		
PAYROLL NO.	FOR WEEK ENDING	PROJECT AND LOCATION	PROJECT OR CONTRACT NO.

(1) NAME AND INDIVIDUAL IDENTIFYING NUMBER (e.g., LAST FOUR DIGITS OF SOCIAL SECURITY NUMBER) OF WORKER	(2) NO. OF WITHHOLDING EXEMPTIONS	(3) WORK CLASSIFICATION	OT OR ST.	(4) DAY AND DATE							(5) TOTAL HOURS	(6) RATE OF PAY	(7) GROSS AMOUNT EARNED	(8) DEDUCTIONS					(9) NET WAGES PAID FOR WEEK
				HOURS WORKED EACH DAY										FICA	WITH- HOLDING TAX		OTHER	TOTAL DEDUCTIONS	
				S	S	S	S	S	S	S									
			O																
			S																
			O																
			S																
			O																
			S																
			O																
			S																
			O																
			S																
			O																
			S																

While completion of Form WH-347 is optional, it is mandatory for covered contractors and subcontractors performing work on Federally financed or assisted construction contracts to respond to the information collection contained in 29 C.F.R. §§ 3.3, 5.5(a). The Copeland Act (40 U.S.C. § 3145) contractors and subcontractors performing work on Federally financed or assisted construction contracts to "furnish weekly a statement with respect to the wages paid each employee during the preceding week." U.S. Department of Labor (DOL) regulations at 29 C.F.R. § 5.5(a)(3)(i) require contractors to submit weekly a copy of all payrolls to the Federal agency contracting for or financing the construction project, accompanied by a signed "Statement of Compliance" indicating that the payrolls are correct and complete and that each laborer or mechanic has been paid not less than the proper Davis-Bacon prevailing wage rate for the work performed. DOL and federal contracting agencies receiving this information review the information to determine that employees have received legally required wages and fringe benefits.

**Public Burden Statement**

We estimate that it will take an average of 55 minutes to complete this collection, including time for reviewing instructions, searching existing data sources, gathering and maintaining the data needed, and completing and reviewing the collection of information. If you have any comments regarding these estimates or any other aspect of this collection, including suggestions for reducing this burden, send them to the Administrator, Wage and Hour Division, U.S. Department of Labor, Room S3502, 200 Constitution Avenue, N.W. Washington, D.C. 20210

(over)

Date \_\_\_\_\_

I, \_\_\_\_\_ (Name of Signatory Party) \_\_\_\_\_ (Title)

do hereby state:

(1) That I pay or supervise the payment of the persons employed by

\_\_\_\_\_ on the \_\_\_\_\_ (Contractor or Subcontractor)

\_\_\_\_\_ (Building or Work); that during the payroll period commencing on the \_\_\_\_\_

\_\_\_\_\_ day of \_\_\_\_\_, \_\_\_\_\_, and ending the \_\_\_\_\_ day of \_\_\_\_\_, \_\_\_\_\_, all persons employed on said project have been paid the full weekly wages earned, that no rebates have been or will be made either directly or indirectly to or on behalf of said

\_\_\_\_\_ from the full \_\_\_\_\_ (Contractor or Subcontractor)

weekly wages earned by any person and that no deductions have been made either directly or indirectly from the full wages earned by any person, other than permissible deductions as defined in Regulations, Part 3 (29 C.F.R. Subtitle A), issued by the Secretary of Labor under the Copeland Act, as amended (48 Stat. 948, 63 Stat. 108, 72 Stat. 967; 76 Stat. 357; 40 U.S.C. § 3145), and described below:

\_\_\_\_\_  
 \_\_\_\_\_  
 \_\_\_\_\_  
 \_\_\_\_\_

(2) That any payrolls otherwise under this contract required to be submitted for the above period are correct and complete; that the wage rates for laborers or mechanics contained therein are not less than the applicable wage rates contained in any wage determination incorporated into the contract; that the classifications set forth therein for each laborer or mechanic conform with the work he performed.

(3) That any apprentices employed in the above period are duly registered in a bona fide apprenticeship program registered with a State apprenticeship agency recognized by the Bureau of Apprenticeship and Training, United States Department of Labor, or if no such recognized agency exists in a State, are registered with the Bureau of Apprenticeship and Training, United States Department of Labor.

(4) That:

(a) WHERE FRINGE BENEFITS ARE PAID TO APPROVED PLANS, FUNDS, OR PROGRAMS

— in addition to the basic hourly wage rates paid to each laborer or mechanic listed in the above referenced payroll, payments of fringe benefits as listed in the contract have been or will be made to appropriate programs for the benefit of such employees, except as noted in section 4(c) below.

(b) WHERE FRINGE BENEFITS ARE PAID IN CASH

— Each laborer or mechanic listed in the above referenced payroll has been paid, as indicated on the payroll, an amount not less than the sum of the applicable basic hourly wage rate plus the amount of the required fringe benefits as listed in the contract, except as noted in section 4(c) below.

(c) EXCEPTIONS

EXCEPTION (CRAFT)	EXPLANATION

REMARKS:

NAME AND TITLE	SIGNATURE
----------------	-----------

THE WILLFUL FALSIFICATION OF ANY OF THE ABOVE STATEMENTS MAY SUBJECT THE CONTRACTOR OR SUBCONTRACTOR TO CIVIL OR CRIMINAL PROSECUTION. SEE SECTION 1001 OF TITLE 18 AND SECTION 231 OF TITLE 31 OF THE UNITED STATES CODE.

---

InstructionsGeneral:

This form is to be used by HUD and local agency staff for recording information gathered during on-site interviews with laborers and mechanics employed on projects subject to Federal prevailing wage requirements. Typically, the staff that will conduct on-site interviews and use this form are HUD staff and fee construction inspectors, HUD Labor Standards staff, and local agency labor standards contract monitors.

Information recorded on the form HUD-11 is evaluated for general compliance and compared to certified payroll reports submitted by the respective employer. The comparison tests the veracity of the payroll reports and may be critical to the successful conclusion of enforcement actions in the event of labor standards violations. The thoroughness and accuracy of the information gathered during interviews is crucial.

Note that the interview itself and the information collected on the form HUD-11 are considered confidential. Interviews should be conducted individually and privately. All laborers and mechanics employed on the job site must be made available for interview at the interviewer's request. The employee's participation, however, is voluntary. Interviews shall be conducted in a manner and place that are conducive to the purposes of the interview and that cause the least inconvenience to the employer(s) and the employee(s).

Completing the form HUD-11:

Items 1a - 1c: Self-explanatory

Items 2a – 2d: Enter the employee's full name, a telephone number where the employee can be reached, and the employee's home address. Many construction workers use a temporary address in the locality of the project and have a more permanent address elsewhere from which mail may be forwarded to them. Obtain a more permanent address, if available. Ask the employee for a form of identification (e.g., driver's license) to verify their name.

Items 3a – 4c: Enter the employee's responses. Ask the employee whether they have a pay stub with them; if so, determine whether the pay stub is consistent with the information provided by the employee.

Items 5 – 7: Be certain that the employee's responses are specific. For example, job classification (#5) must identify the trade involved (e.g., Carpenter, Electrician, Plumber) – responses such as "journeyman" or "mechanic" are not helpful for our purposes.

Items 8 – 12b: Self-explanatory

Items 13 – 15c: These items represent some of the most important information that can be gathered while conducting on-site interviews. Please be specific about the duties you observed the employee performing. It may be easiest to make these observations before initiating the interview. Please record any comments or remarks that may be helpful. For example, if the employee interviewed was working with a crew, how many workers were in the crew? Was the employee evasive?

The level of specificity that is warranted is directly related to the extent to which interview(s) or other observations indicate that there may be violations present. If interviews indicate that there may be underpayments involving a particular trade(s), the interviewer is encouraged to interview as many workers in that trade(s) that are available.

Items 16 – 17b: The information on the form HUD-11 may be reviewed for general compliance, initially. For example, are the job classification and wage rate stated by the employee compatible with the classifications and wage rates on the applicable wage decision? Are the duties observed by the interviewer consistent with the job classification?

Item 18: Please place here any additional information you may want to document or continuing information from other lines that do not fit in their block space.

Once the corresponding certified payroll reports are received, the information on the HUD-11 shall be compared to the payroll reports. Any discrepancies noted between the HUD-11 information and that on the payroll report shall be noted in Item 16, Remarks. If discrepancies are noted, follow-up actions to resolve the discrepancies must be taken.

# Record of Employee Interview

## U.S. Department of Housing and Urban Development Office of Davis-Bacon and Labor Standards

OMB Approval No. 2501-0009  
(exp. 12/31/2024)

The public reporting burden estimate for this collection of information is 15 minutes per response on average. This includes reviewing instructions, searching existing data sources, gathering, and maintaining the data, and completing the collection of information. This information may not be collected, nor are you required to provide, the information requested unless it displays a currently valid OMB control number. The information collected ensures compliance with the Federal labor standards through recording interviews with construction workers. The information collected assists HUD in compliance monitoring of Federal labor standards. Any information collected is covered by the Privacy Act of 1974 and by 29 CFR 5.6(a)(5). Individuals and agencies collecting this information must maintain these records in a manner that protects the individuals on whom the information is maintained. The information collected herein is voluntary, and any information provided shall be kept confidential, but failure to provide the information collected may delay enforcement of any possible Federal labor standards violations if the information would have identified any. Comments concerning this burden statement, or this collection should be sent to: National Director, Office of Davis-Bacon and Labor Standards, 451 7th Street SW, Room 7108, Washington, DC 20410. When providing comments, please refer to OMB Approval 2501-0009

Pursuant to 5 U.S.C. § 552a(e)(3), this Privacy Act Statement serves to inform you of the following concerning the collection of the information on this form.  
**A. AUTHORITY:** Collection of the information solicited on this form is authorized by the Davis-Bacon Act as promulgated through Department of Labor Regulations under 29 CFR Part 5.  
**B. PURPOSE:** The primary purpose for soliciting this information is to determine if the wages paid by an employer on a project covered by the Davis-Bacon Act are in compliance with federal labor standards.  
**C. ROUTINE USES:** The information collected ensures compliance with the Federal labor standards through recording interviews with construction workers on topics related to wages paid on the project. The information is reviewed by HUD authorized personnel to ensure compliance with Federal labor standards under the Davis-Bacon Act on covered projects. If violations are found, the information collected is used to conduct enforcement actions to ensure restitution is paid to workers of covered projects are paid proper wages under the Davis-Bacon Act.  
**D. CONSEQUENCES OF FAILURE TO PROVIDE INFORMATION:** The information collection is voluntary. Refusing to give information will not impact your status with your employer or the government. Failure to provide the information will limit the ability of HUD to determine if you were paid proper wages under the Davis-Bacon Act, and will limit the ability for HUD to seek restitution for you in the event a violation is found.

1a. Project Name			2a. Employee Name		
1b. Project Number			2b. Employee Phone Number (including area code)		
1c. Contractor or Subcontractor (Employer)			2c. Employee Home Address & Zip Code		
			2d. Verification of identification? Yes      No		
3a. How long on this job?	3b. Last date on this job before today?	3c. No. of hours last day on this job?	4a. Hourly rate of pay?	4b. Fringe Benefits?	4c. Pay stub?
				Vacation    Yes    No Medical      Yes    No Pension      Yes    No	Yes      No
5. Your job classification(s) (list all) --- continue in block 18 if necessary					
6. Your duties --- continue in block 18 if necessary					
7. Tools or equipment used --- continue in block 18 if necessary					
8. Are you an apprentice or trainee?    Yes      No		10. Are you paid at least time and ½ for all hours worked in excess of 40 in a week?    Yes      No			
9. Are you paid for all hours worked?    Yes      No		11. Have you ever been threatened or coerced into giving up any part of your pay?    Yes      No			
12a. Employee Signature			12b. Date		
13. Duties observed by the Interviewer (Please be specific.)					
14. Remarks --- continue in block 18 if necessary					
15a. Interviewer Name (Please Print)		15b. Signature of Interviewer		15c. Date of Interview	
<b>Payroll Examination</b>					
16. Remarks --- continue in block 18 if necessary					
17a. Signature of Payroll Examiner			17b. Date		

EQUAL EMPLOYMENT OPPORTUNITY FORMS FOR  
CONTRACTORS & SUBCONTACTORS WITH  
CONTRACTS OVER \$10,000

- (1) CONTRACTOR'S NOTIFICATION OF SUBCONTRACTS AWARDED
  
- (2) CONTRACTOR'S LIST OF FEDERAL & NON-FEDERAL WORK IN BID  
CONDITION AREAS

The “Notification of Subcontractors Awarded” and “Contractor’s List of Federal & Non-Federal Work in Bid Condition Areas” are to be completed and submitted to the Subrecipient or their designated representative (Engineer, Consultant, Architect, etc.), prior to project and construction completion.



# Suggested Format

## Contractors Notification of Subcontracts Awarded

Location: \_\_\_\_\_

General Contractor's Name: \_\_\_\_\_

Month of: \_\_\_\_\_

CDBG Project Number: \_\_\_\_\_

Subcontractor's Name	Dollar Amount	Estimated		Crafts to be Used
		Starting Date	Completion Date	
(1)				
(2)				
(3)				
(4)				
(5)				
(6)				
(7)				
(8)				
(9)				
(10)				
(11)				



**CONTRACTOR’S LIST OF FEDERAL AND NON-FEDERAL WORK IN BID CONDITION AREAS**

**BID CONDITION AREA:** \_\_\_\_\_ **CONTRACTOR’S NAME& NUMBER:** \_\_\_\_\_

**I. Federally-Assisted Contracts**

Responsible Federal Agency	Project Name & Location*	Contract/Project Number	Dollar Amount	Percent Complete	Projected Completion Date
(1)					
(2)					
(3)					
(4)					
(5)					

**II. Non-Federal Contracts**

Project Name & Location	Contract/Project Number	Dollar Amount	Percent Complete	Projected Completion Date
(1)				
(2)				
(3)				
(4)				
(5)				

\*LOCATIONS MUST INCLUDE CITY AND STREET ADDRESS

SECTION 3 FORMS FOR CONTRACTORS &  
SUBCONTRACTORS WITH CONTRACTS  
OVER \$200,000

- (1) PRELIMINARY STATEMENT OF WORKFORCE NEEDS
- (2) SECTION 3 FINAL RULE REPORT  
*(Only complete if the project received funding over \$200,000.00)*
- (3) SECTION 3 REQUIRED CERTIFICATIONS
  - \*Section 3: Acknowledgement of Compliance Requirements*
  - \*Section 3: Compliance Certification*
  - \*Section 3: Employer Self-Certification Checklist*
  - \*Section 3: Employee Self-Certification Checklist*

BUILD AMERICA, BUY AMERICA (BABA) FOR  
CONTRACTORS & SUBCONTRACTORS WITH  
CONTRACTS OVER \$250,000

BUILD AMERICA, BUY AMERICA (BABA)  
*(All iron, steel, manufactured products, and construction materials used for the project are produced in the United States.)*

*\*Build America, Buy America Act: Employer Self-Certification*

To ensure full compliance with the CDBG Program, copies of the reports and completed forms must be submitted to the Subrecipient or their designated representative (Engineer, Consultant, Architect, etc.), prior to project and construction completion.



**PRELIMINARY STATEMENT  
WORK FORCE NEEDS**

Municipality or Contractor's Name \_\_\_\_\_

Address and City \_\_\_\_\_

Date: \_\_\_\_\_

EMPLOYMENT CLASSIFICATION	OCCUPIED PERMANENT POSITION				VACANT POSITIONS**				*Minority African-American Hispanic Asian Native American  **Show Section 3 lower income residents only under the Grand Total vacant positions slanted line  ***To be used by municipalities and service contractors, such as engineering, consulting firms and other similar firms.
	TOTAL		MINORITY*		TOTAL		MINORITY		
	MALE	FEMALE	MALE	FEMALE	MALE	FEMALE	MALE	FEMALE	
CONSTRUCTION:									
Foreman									
Journeyman									
Apprentices									
Labors									
GRAND TOAL					/	/	/	/	
NON-CONSTRUCTION***									
Administrators									
Professionals									
Technicians									
Clerks									
Labors									
GRAND TOAL					/	/	/	/	

Submitted By: \_\_\_\_\_  
(Official responsible for filling out this form)

Phone: \_\_\_\_\_

## SECTION 3 – FINAL RULE REPORT

Section 3 ensures employment and other economic opportunities generated by the HUD financial assistance goes, to the greatest extent feasible, toward Low-and very low-income persons and businesses. Section 3 applies to HUD-provided Housing (HOME/HTF), Community Development and Public Housing Programs.

Recipient Name & Address (street, city, state, zip):	Federal Identification/grant no.:	Total Amount of Award:
Contact Person:	Phone:	Email:
Program Name:	Reporting Period:	Length of Grant:
Date Submitted:		

### Part I Information Regarding Agency Employment

Complete the table below for contracts/subcontracts or agency's receiving \$200,000 or more of HUD financial assistance for this project. Please report labor hours generated in connection with this HUD-provided housing (HOME/HTF), community development, and public housing projects. Include labor hours for part-time and full-time positions, along with contractor, subcontractors and agency staff working on this project. Contracts, subcontracts or agencies receiving a \$100,000.00 or more for Lead Hazard Control Projects must also report.

#### Section 3 – Reporting Form:

	Hour	Calculated Percentage	Safe Harbor Benchmark Met (Yes or No)	Benchmarks
<b>Total Labor Hours</b>				
<b># of Labor Hours of Section 3 Workers</b>				<b>5%</b>
<b># of Labor Hours of Targeted Section 3 Workers</b>				<b>25%</b>

**Section 3 Worker:** Any worker who currently fits, or when hired within the past five years, fit a least one of the following criteria:

- Low- or very low-income (as established by HUD's income limits)
- Employed by a Section 3 business concern\*
- A Youth Build participant

**Targeted Section 3 Worker:** A Section 3 Worker who resides within the project's neighborhood or service area, defined as:

- one-mile radius of project site, or
- if area population <5,000, up to a radius containing 5,000 people.

**\*Section 3 Business Concern:** Businesses that meet one of the following criteria (in the last 6 months):

- At least 51% owned and controlled by low-income or very low-income persons.
- Over 75% of labor hours are performed by Section 3 Workers.
- At least 51%, owned and controlled by current residents of public housing or Section 8 assisted housing.

**\*\*Safe Harbor Benchmarks:** 25% of total hours or 5% of hours contracted to targeted workers.

## Part II Nature of Agency Efforts

This section is required if, based on the labor hours reporting above, the reporting agency did not meet the safe harbor benchmarks\*\*. Check all that apply and submit documentation on any efforts checked.

	Outreach efforts to generate job applicants who are Public Housing Targeted Workers.
	Outreach efforts to generate job applicants who are Other Funding Targeted Workers.
	Direct, on-the-job training (including apprenticeships).
	Indirect training such as arranging for, contracting for, or paying tuition for, off-site training.
	Technical assistance to help Section 3 workers compete for jobs (e.g., resume assistance, coaching).
	Outreach efforts to identify and secure bids from Section 3 business concerns.
	Technical assistance to help Section 3 business concerns understand and bid on contracts.
	Division of contracts into smaller jobs to facilitate participation of Section 3 business concerns.
	Provided or connected residents with assistance in seeking employment which include drafting resumes, preparing for interviews, finding job opportunities, referring to job placement services.
	Held one or more job fairs.
	Provided or connected residents with supportive services that can provide direct services or referrals.
	Provided or connected residents with supportive services that provide one or more of the following: work readiness health screenings, interview clothing, uniforms, test fees, transportation.
	Assisted residents with finding childcare.
	Assisted residents to apply for/or attend community college or a four-year educational institution.
	Assisted residents to apply for/or attend vocational/technical training.
	Assisted residents to obtain financial literacy training and/or coaching.
	Bonding assistance, guaranties, or other efforts to support viable bids from Section 3 business concerns.
	Provided or connected residents with computer training or online technical assistance.
	Other, please specify:

Describe your agency's employee retention plan: \_\_\_\_\_

---



---



---



---

**SECTION 3: ACKNOWLEDGEMENT OF COMPLIANCE REQUIREMENTS**

**Section 3 of the HUD Act of 1968 (12 U.S.C § 1701u) and its associated regulations (24 C.F.R. Part 75)**

**Project Name:** \_\_\_\_\_ **HUD Grant:** CDBG / HOME **HUD Assistance:** \$ \_\_\_\_\_

*The requirements of Section 3 apply to contractors and subcontractors performing work on construction or rehabilitation projects for which the amount of HUD financial assistance exceeds \$200,000. All contractors and subcontractors, regardless of the funding total, must execute the following acknowledgement (referred to as the Acknowledgement of Compliance Requirements) to acknowledge they have reviewed and understand Section 3 compliance for the HUD-funded project.*

*Review and initial each statement:*

\_\_\_\_\_ HUD financial assistance for the project does / does not (circle one) exceed \$200,000.

\_\_\_\_\_ The parties will comply with HUD's regulations in 24 CFR part 75, which implement Section 3. The parties certify that they are under no impediment that would prevent them from complying with the Part 75 regulations.

\_\_\_\_\_ The parties acknowledge noncompliance with HUD's regulations in 24 CFR part 75 may result in sanctions, termination of this contract for default, and debarment or suspension from future HUD-assisted contracts.

**SECTION 3 BUSINESS CONCERN:**

\_\_\_\_\_ A Section 3 business concern is a business that meets at least one of the following criteria, documented within the last six-month period:

1. At least 51 percent owned and controlled by low- or very low-income persons;
2. Over 75 percent of the labor hours performed for the business over the prior three-month period are performed by Section 3 workers; or
3. A business at least 51 percent owned and controlled by current public housing residents or residents who currently live in Section 8-assisted housing.

**SECTION 3 WORKER:**

\_\_\_\_\_ A Section 3 worker is any worker who currently fits, or when hired within the past five years fit, at least one of the following categories, as documented:

1. The worker's income for the previous or annualized calendar year is below the income limit established by HUD:

<b>Individual Annual Income</b>	<b>1</b>
80 % (gross income)	\$61,800

2. The worker is employed by a Section 3 business concern; or
3. The worker is a YouthBuild participant.

**SECTION 3 TARGETED WORKER:**

\_\_\_\_\_ A Section 3 targeted worker is a worker who:

1. Is employed by a Section 3 business concern; or
2. Currently fits, or when hired fit, at least one of the following categories, as documented within the past five years:
  - a. Living within the service area or the neighborhood of the project, as defined in 24 CFR § 75.5; or
  - b. A YouthBuild participant.

### SECTION 3: ACKNOWLEDGEMENT OF COMPLIANCE REQUIREMENTS

#### HIRING

\_\_\_\_\_ Contractors, to the greatest extent feasible, will fill vacant positions with Section 3 workers or Section 3 targeted workers. Any vacant employment positions, including training positions, that are filled *after* the contractor is selected but *before* the contract is executed, with persons other than those to whom the regulations of 24 CFR part 75 require employment opportunities to be directed, were not filled to circumvent the contractor's obligations under 24 CFR part 75.

#### REPORTING

\_\_\_\_\_ Contractors, to the greatest extent feasible, will make efforts to have Section 3 workers conduct *25 percent* or more of the total number of labor hours worked by all workers on a Section 3 project and Targeted Section 3 workers conduct *5 percent* or more of the total number of labor hours worked by all workers on a Section 3 project (This *5 percent* is included as part of the *25 percent* threshold).

\_\_\_\_\_ Contractors will track labor hours in pursuit of meeting the above outlined benchmarks.

#### EQUAL OPPORTUNITIES

\_\_\_\_\_ The parties agree affirmative action and equal employment opportunity to those who do business with the federal government. It is illegal to discriminate against a job applicant or an employee because of the person's race, color, religion, sex (including pregnancy), national origin, age (40 or older), disability or genetic information (medical history or predisposition to disease).

#### OUTREACH

\_\_\_\_\_ Contractors, to the greatest extent feasible, will conduct outreach to hire Section 3 workers and/or Section 3 targeted workers which includes, but is not limited to:

1. Notify labor organizations or representatives of workers of Section 3 preference, including job titles subject to hire, availability of apprenticeship and training positions, the qualifications for each; and the name and location of the person(s) taking applications for each of the positions; and the anticipated date the work shall begin.
2. Provide technical assistance to help Section 3 workers compete for jobs.

\_\_\_\_\_ Contractors, to the greatest extent feasible, will support hired Section 3 workers and/or Section 3 targeted workers to ensure they have access to resources which includes, but is not limited to:

1. Provide training and/or apprenticeship opportunities.
2. Refer Section 3 workers to services supporting work readiness and retention (e.g., work readiness activities, interview clothing, test fees, transportation, childcare, financial literacy, etc.).
3. Notify laborers on the jobsite of the Section 3 worker qualifications to ensure all employees may complete eligibility certification.

The undersigned agrees to comply with the Section 3 Guidelines when applicable as referenced by HUD regulations in 24 CFR part 75 as amended.

Name/Title (printed)	Company	Signature
Name/Title (printed)	Company	Signature
Name/Title (printed)	Company	Signature

**SECTION 3: COMPLIANCE CERTIFICATION**

Please select a response to the below questions/statements.

1. Has the project been awarded over \$200,000 in HUD assistance? (Please consult the contracting organization if unsure).
  - Yes – continue to question 2
  - No – continue to the bottom of form, complete, sign, date. No additional forms required.
  
2. This project is receiving over \$200,000 of HUD assistance, and either the business itself, and/or any of its employees meet the definition of Section 3. (See Section 3 Acknowledgement of Compliance Requirements form for Business Concern and Worker criteria).
  - True – continue to question 3
  - False – continue to the bottom of form, complete, sign, date. No additional forms required.
  
3. Select how the Section 3 definition is met.
  - The business **and** one or more employees are Section 3 – continue to question 4
  - The business is Section 3; **no** employees are Section 3 – continue to question 4
  - The business is **not** Section 3; one or more employees **are** Section 3 – continue to question 4
  
4. Please list the employee(s) name(s) and job title which meet the definition of a Section 3 Worker:

Please print your name, company, title, and sign/date below.

<b>Company Name</b>	
<b>Name</b>	
<b>Job Title</b>	
<b>Date</b>	
<b>Signature</b>	

*Please complete the corresponding required Section 3 Forms:*

**Section 3 Business Self-Certification Form** – Required from all businesses

**Section 3 Laborer Self-Certification Form** – Required if employee (laborer) of contractor/subcontractor is Section 3



### SECTION 3 EMPLOYER SELF CERTIFICATION CHECKLIST

There are many ways to certify a Section 3 Business, Worker(s), or Targeted Section 3 Worker(s) under 24 CFR part 75:

For the following numbered items, please mark the checkbox that applies to your business with  or

1. For a Business to qualify as a **Section 3 Business Concern**, certification must be provided that the company meets at least one of the following, please select ONE of the below options that applies:
  - At least 51 percent owned and controlled by low- or very low-income persons; or
  - Over 75 percent of the labor hours performed for the business over the prior three-month period are performed by Section 3 workers; or
  - My business is at least 51 percent owned and controlled by current public housing residents or residents who currently live in Section 8-assisted housing.
  
  - None of the above apply to our company.
  
2. For a worker to qualify as a **Section 3 worker**, one of the following must be maintained:
  - My company certifies that the income from this employer is below the income limit when based on an employer's calculation of what the worker's wage rate would translate to if annualized on a full-time basis; or
  
  - My company certifies that our company is a Section 3 business concern; or
  
  - None of the above apply to our company.
  
3. For a worker to qualify as a **Targeted Section 3 worker**, the following must be maintained:
  - My company's confirmation that our **worker's residence is currently within one mile of the work site or when hired resided within one mile of the work site, as documented within the last five years**, or, if fewer than 5,000 people live within one mile of a work site, within a circle centered on the work site that is sufficient to encompass a population of 5,000 people according to the most recent U.S. Census;
  
  - My company certifies that our company is a Section 3 business concern; or
  
  - None of the above apply to our company.

Please use the below information to determine if your employee(s) meet the criteria for the first option of question #1. Low- and very low-income limits are defined in Section 3(b)(2) of the Housing Act of 1937 and are determined annually by HUD. These limits are typically established at 80 percent and 50 percent of the area median individual income. HUD income limits may be obtained from: <https://www.huduser.gov/portal/datasets/il.html>. This website also provides detailed explanations on how to calculate your annual income to compare it to this below income limits summary:

<b>Individual Annual Income</b>	<b>1</b>
80 % (gross income)	\$61,800

- I certify that my employee(s) meet the requirements of the Section 3 worker/Targeted Section 3 worker (If you checked the above box, please list the qualifying employees on the next page)
  
  - I certify that my employee(s) **DO NOT** meet the requirements of the Section 3 worker/Targeted Section 3 worker
4. Not all businesses will meet the requirements of a Business Concern or have Section 3 or Targeted Section 3 employees. In that case, the U.S. Department of Housing and Urban Development requires qualitative outreach

efforts be made to Section 3 workers. Please select all that apply to your company which demonstrate qualitative efforts put forth to meet federal Section 3 requirements:

- Engaged in outreach efforts to generate job applicants who are Targeted Section 3 workers.
- Provided training or apprenticeship opportunities.
- Provided technical assistance to help Section 3 workers compete for jobs (*e.g.*, resume assistance, coaching).
- Provided or connected Section 3 workers with assistance in seeking employment including: drafting resumes, preparing for interviews, and finding job opportunities connecting residents to job placement services.
- Held one or more job fairs.
- Provided or referred Section 3 workers to services supporting work readiness and retention (*e.g.*, work readiness activities, interview clothing, test fees, transportation, child care).
- Provided assistance to apply for/or attend community college, a four-year educational institution, or vocational/technical training.
- Assisted Section 3 workers to obtain financial literacy training and/or coaching.
- Engaged in outreach efforts to identify and secure bids from Section 3 business concerns.
- Provided technical assistance to help Section 3 business concerns understand and bid on contracts.
- Divided contracts into smaller jobs to facilitate participation by Section 3 business concerns.
- Provided bonding assistance, guaranties, or other efforts to support viable bids from Section 3 business concerns.
- Promoted use of business registries designed to create opportunities for disadvantaged and small businesses.
- Outreach, engagement, or referrals with the state one-stop system as defined in Section 121(e)(2) of the Workforce Innovation and Opportunity Act.

I affirm that the above statements are true, complete, and correct to the best of my knowledge and belief. I understand that businesses who misrepresent themselves as Section 3 business concerns and report false information to DuPage County may have their contracts terminated as default and be barred from ongoing and future considerations for contracting opportunities. I hereby certify, under penalty of law, that the information contained in this document is correct to the best of my knowledge.

<b>Name (printed)</b>	<b>Company</b>	<b>Signature</b>
<b>Title</b>	<b>Project Name</b>	<b>Laborer Trade</b>

Please provide the details of all employees meeting the Section 3 requirements from the previous page:  
 (print additional forms if necessary)

<b>Name (printed)</b>	<b>Section 3 Worker (Yes/No)</b>	<b>Targeted Section 3 Worker (Yes/No)</b>
<b>Name (printed)</b>	<b>Section 3 Worker (Yes/No)</b>	<b>Targeted Section 3 Worker (Yes/No)</b>
<b>Name (printed)</b>	<b>Section 3 Worker (Yes/No)</b>	<b>Targeted Section 3 Worker (Yes/No)</b>
<b>Name (printed)</b>	<b>Section 3 Worker (Yes/No)</b>	<b>Targeted Section 3 Worker (Yes/No)</b>
<b>Name (printed)</b>	<b>Section 3 Worker (Yes/No)</b>	<b>Targeted Section 3 Worker (Yes/No)</b>
<b>Name (printed)</b>	<b>Section 3 Worker (Yes/No)</b>	<b>Targeted Section 3 Worker (Yes/No)</b>
<b>Name (printed)</b>	<b>Section 3 Worker (Yes/No)</b>	<b>Targeted Section 3 Worker (Yes/No)</b>
<b>Name (printed)</b>	<b>Section 3 Worker (Yes/No)</b>	<b>Targeted Section 3 Worker (Yes/No)</b>
<b>Name (printed)</b>	<b>Section 3 Worker (Yes/No)</b>	<b>Targeted Section 3 Worker (Yes/No)</b>
<b>Name (printed)</b>	<b>Section 3 Worker (Yes/No)</b>	<b>Targeted Section 3 Worker (Yes/No)</b>
<b>Name (printed)</b>	<b>Section 3 Worker (Yes/No)</b>	<b>Targeted Section 3 Worker (Yes/No)</b>
<b>Name (printed)</b>	<b>Section 3 Worker (Yes/No)</b>	<b>Targeted Section 3 Worker (Yes/No)</b>
<b>Name (printed)</b>	<b>Section 3 Worker (Yes/No)</b>	<b>Targeted Section 3 Worker (Yes/No)</b>
<b>Name (printed)</b>	<b>Section 3 Worker (Yes/No)</b>	<b>Targeted Section 3 Worker (Yes/No)</b>
<b>Name (printed)</b>	<b>Section 3 Worker (Yes/No)</b>	<b>Targeted Section 3 Worker (Yes/No)</b>

**SECTION 3 EMPLOYEE SELF CERTIFICATION CHECKLIST**

The purpose of HUD’s Section 3 program is to provide employment, training and contracting opportunities to low-income individual, particularly those who are recipients of government assistance for housing or other public assistance. **Your response is voluntary, confidential, and has no effect on your employment.**

There are many ways to certify a Section 3 Worker or Targeted Section 3 Worker under 24 CFR part 75:

For the following numbered items, please mark the checkbox that applies to you with  or

1. For a worker to qualify as a **Section 3 worker**, one of the following must be maintained:
  - I certify that my income is below the income limit from the prior calendar year (see income limit below);
  - I certify that I participate in a means-tested program such as public housing or Section 8 assisted housing;
  - Certification from a PHA, or the owner or property manager of project-based Section 8-assisted housing, or the administrator of tenant-based Section 8-assisted housing that the worker is a participant in one of their programs;
  - My employer’s certification that my income from that employer is below the income limit when based on an employer’s calculation of what the worker’s wage rate would translate to if annualized on a full-time basis; or
  - My employer’s certification that I am a worker who is employed by a Section 3 business concern;
  - None of the above apply to me;
  - I prefer not to answer.
  
2. For a worker to qualify as a **Targeted Section 3 worker**, the following must be maintained:
  - My employer’s confirmation that my residence is within one mile of the work site or, if fewer than 5,000 people live within one mile of a work site, within a circle centered on the work site that is sufficient to encompass a population of 5,000 people according to the most recent U.S. Census;
  - My employer’s certification that I am employed by a Section 3 business concern; or
  - I certify that I am a YouthBuild participant;
  - None of the above apply to me;
  - I prefer not to answer.

Please use the below information to determine if you meet the criteria for the first and fourth options of question #1. Low- and very low-income limits are defined in Section 3(b)(2) of the Housing Act of 1937 and are determined annually by HUD. These limits are typically established at 80 percent and 50 percent of the area median individual income. HUD income limits may be obtained from: <https://www.huduser.gov/portal/datasets/il.html>. This website also provides detailed explanations on how to calculate your annual income to compare it to this below income limits summary:

<b>Individual Annual Income</b>	<b>1</b>
80 % (gross income)	\$61,800

- I certify that I meet the requirements of either the Section 3 worker or the Targeted Section 3 worker
- I certify that **I DO NOT** meet the requirements of either the Section 3 worker or the Targeted Section 3 worker

I affirm and hereby certify, under penalty of law, the information provided and the above selected statements are true, complete, and correct to the best of my knowledge and belief.

<b>Name (printed)</b>	<b>Address</b>	<b>Employer</b>
<b>Signature</b>	<b>Project Name</b>	<b>Laborer Trade</b>

---

**BUILD AMERICA, BUY AMERICA ACT: EMPLOYER SELF-CERTIFICATION**

The undersigned certifies, to the best of their knowledge and belief, that:

The Build America, Buy America Act (BABAA) requires that no federal financial assistance for “infrastructure” projects is provided “unless all of the iron, steel, manufactured products, and construction materials used in the project are produced in the United States.” Section 70914 of Public Law No. 117-58, §§ 70901-52.

The undersigned certifies that for the *(please insert project name)* \_\_\_\_\_  
\_\_\_\_\_, *(insert project location)* \_\_\_\_\_

the iron, steel, manufactured products, and construction materials used in this contract are in full compliance with the BABAA requirements including:

1. All iron and steel used in the project are produced in the United States. This means all manufacturing processes, from the initial melting stage through the application of coatings, occurred in the United States.
2. All manufactured products purchased with FEMA financial assistance must be produced in the United States. For a manufactured product to be considered produced in the United States, the cost of the components of the manufactured product that are mined, produced, or manufactured in the United States is greater than 55% of the total cost of all components of the manufactured product, unless another standard for determining the minimum amount of domestic content of the manufactured product has been established under applicable law or regulation.
3. All construction materials are manufactured in the United States. This means that all manufacturing processes for the construction material occurred in the United States.

“The, *(insert contractor or subcontractor company name)* \_\_\_\_\_  
\_\_\_\_\_, certifies or affirms the truthfulness and accuracy of each statement of its certification and disclosure, if any. In addition, the [Contractor or Subcontractor] understands and agrees that the provisions of 31 U.S.C. Chap. 38, Administrative Remedies for False Claims and Statements, apply to this certification and disclosure, if any.”

---

Signature of [Contractor or Subcontractor] Authorized Official

---

Name and Title of [Contractor or Subcontractor] Authorized Official (Print)

---

Date

**COOK COUNTY DAVIS-BACON CONSTRUCTION PACKET CERTIFICATION – Signatures Required**

***Please sign two documents; one for the CDBG Grant Administrator and one for the Contractor.***

It is acknowledged that HUD and Cook County Davis-Bacon and Labor Standards Regulations information was provided and the below Subrecipient and Contractor agrees to comply with all regulations as discussed:

CDBG Subrecipient Printed Name \_\_\_\_\_ CDBG Subrecipient

Signature \_\_\_\_\_ Date \_\_\_\_\_

Contractor Printed Name \_\_\_\_\_

Contractor Signature \_\_\_\_\_ Date \_\_\_\_\_

Submit the following documents to the CDBG Subrecipient to be forwarded to the CDBG Grant Administrator:

- Complete and return all required Davis Bacon Construction Packet documentation
- Post all required Labor Standards Regulations signage
- Post all Prevailing Wage (General Decision Number) signage
- Other items as required.

# **APPENDIX C**

**(Bid Specifications)**



# 13TH STREET RESURFACING, HYDRANT REPLACEMENT, AND WATER MAIN REPAIR PROJECT VILLAGE OF FORD HEIGHTS

13TH STREET FROM COTTAGE GROVE AVENUE TO WOODLAWN AVENUE  
VILLAGE OF FORD HEIGHTS, COOK COUNTY, ILLINOIS

## ABBREVIATIONS

AVE	AVENUE
CL	CENTERLINE
CU. YDS	CUBIC YARDS
E	EASTING
EG	EXISTING GRADE
EOP	EDGE OF PAVEMENT
ELEV.	ELEVATION
EX.	EXISTING
FL	FLOW LINE
G	GUTTER
GR.	GRATE
HOR.	HORIZONTAL
HMA	HOT MIX ASPHALT
HWY	HIGHWAY
INV.	INVERT
L.F.	LINEAR FEET
LN	LANE
LT	LEFT
MAX.	MAXIMUM
MH	MANHOLE
MIN.	MINIMUM
N	NORTHING
OFF	OFFSET
NO	NUMBER
N.T.S.	NOT TO SCALE
PI	POINT OF INTERSECTION
PL	PLACE
SQ. YDS	SQUARE YARDS
ST	STREET
ROW	RIGHTS-OF-WAY
RT	RIGHT
STA	STATION
STM.	STORM
TYP.	TYPICAL
VERT	VERTICAL

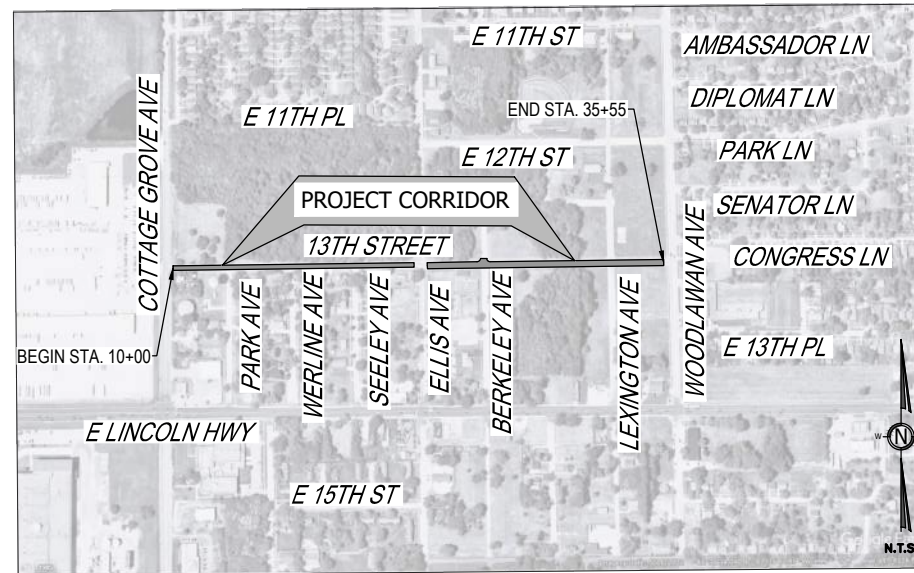

VICINITY MAP

## SHEET INDEX

Sheet Number	Sheet Title
C-01	COVER SHEET
C-02	NOTES AND LEGEND
C-03	TYPICAL CROSS SECTIONS
C-04	SUMMARY OF QUANTITIES
C-05	SIGNAGE PLAN
C-06	KEY MAP
C-07	CONSTRUCTION PLAN STA 10+00 THRU 23+50
C-08	CONSTRUCTION PLAN STA 23+50 THRU 35+55
C-09 THRU C-19	STANDARDS AND DETAILS

## CONTACT INFORMATION

**OWNER**  
VILLAGE OF FORD HEIGHTS  
MAYOR CHARLES R. GRIFFIN  
1343 ELLIS AVENUE  
FORD HEIGHTS, IL 60411  
PHONE: 708-758-3131  
CHARLES.GRIFFIN@FORDHEIGHTS.ORG

**CIVIL ENGINEER**  
MIKE SNEED, PE  
THE ANTERO GROUP, LLC.  
1631 W. WALNUT STREET, 2ND FLOOR  
CHICAGO, IL 60612  
PHONE: 404-717-3582  
MSNEED@ANTEROGROUP.COM

**FORD HEIGHTS PUBLIC WORKS DEPARTMENT**  
SCOTTIE HATTEN  
1343 ELLIS AVENUE  
FORD HEIGHTS, IL 60411  
PHONE: 708-758-3131

**METROPOLITAN WATER RECLAMATION DISTRICT OF GREATER CHICAGO (MWRD)**  
100 EAST ERIE STREET  
CHICAGO, IL 60611  
PHONE: 312-751-5600

File Location: C:\Users\Emily.Eng\OneDrive - Antero Group\Projects\Village of Ford Heights\FH-2303\_Water System Improvements Phase I\DWG\Sheets\FH-2303-COV.dwg Plot Date: 3/19/2024 1:25 PM Last Saved By: EMILY.ENG



No.	DATE	REVISION DESCRIPTION

PREPARED FOR  
VILLAGE OF FORD HEIGHTS  
1343 ELLIS AVENUE  
FORD HEIGHTS, IL 60411



13TH STREET RESURFACING PROJECT

COVER SHEET

VILLAGE OF FORD HEIGHTS, COOK COUNTY, ILLINOIS

JOB NUMBER  
FH-2303  
DATE  
03-06-2024  
SHEET  
C-01













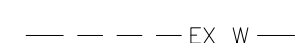

**GENERAL NOTES:**

1. THE ILLINOIS DEPARTMENT OF TRANSPORTATION, STANDARD SPECIFICATIONS, CURRENT EDITION SHALL GOVERN THE PERFORMANCE OF THE WORK. PROJECT SPECIFICATIONS, SPECIAL PROVISIONS, CONSTRUCTION PLANS AND SUBSEQUENT DETAILS ARE ALSO TO BE CONSIDERED AS PART OF THE CONTRACT. INCIDENTAL ITEMS OR ACCESSORIES NECESSARY TO COMPLETE THE WORK MAY NOT BE SPECIFICALLY NOTED BUT ARE TO BE CONSIDERED AS PART OF THE CONTRACT.
2. BEFORE STARTING ANY EXCAVATION, THE CONTRACTOR SHALL CALL 811 FOR FIELD LOCATIONS OF ALL UTILITIES.
3. THE VILLAGE OF FORD HEIGHTS IS TO BE NOTIFIED OF ANY ROAD CLOSURES AT LEAST 48 HOURS PRIOR TO CLOSURE.
4. ALL PAVEMENT MARKINGS ARE TO BE WHITE, THERMOPLASTIC PER IDOT SPECIFICATIONS.
5. NO CONSTRUCTION PLANS SHALL BE USED FOR CONSTRUCTION UNLESS SPECIFICALLY MARKED "FOR CONSTRUCTION." PRIOR TO COMMENCEMENT OF CONSTRUCTION, THE CONTRACTOR SHALL VERIFY ALL DIMENSIONS AND CONDITIONS AFFECTING THE WORK WITH THE ACTUAL CONDITIONS AT THE JOB SITE. IN ADDITION, THE CONTRACTOR MUST VERIFY THE ENGINEER'S LINE AND GRADES. IF THERE ARE ANY DISCREPANCIES FROM WHAT IS SHOWN ON THE CONSTRUCTION PLANS, STANDARD SPECIFICATIONS AND/OR SPECIAL DETAILS, THE CONTRACTOR SHALL SECURE WRITTEN INSTRUCTION FROM THE ENGINEER PRIOR TO PROCEEDING WITH ANY PART OF THE WORK AFFECTED BY OMISSION OR DISCREPANCIES. FAILING TO SECURE SUCH INSTRUCTION, THE CONTRACTOR WILL BE CONSIDERED TO HAVE PROCEEDED AT HIS OWN RISK AND EXPENSE. IN THE EVENT OF ANY DOUBT OR QUESTION ARISING WITH RESPECT TO THE TRUE MEANING OF THE CONSTRUCTION PLANS OR SPECIFICATIONS, THE DECISION OF THE ENGINEER SHALL BE FINAL AND CONCLUSIVE.
6. BEFORE ACCEPTANCE BY THE OWNER AND FINAL PAYMENT, ALL WORK SHALL BE INSPECTED AND APPROVED BY THE OWNER OR THEIR REPRESENTATIVES. FINAL PAYMENT WILL BE MADE AFTER ALL OF THE CONTRACTOR'S WORK HAS BEEN APPROVED AND ACCEPTED.
7. THE CONTRACTOR SHALL BE RESPONSIBLE FOR CLEANING ANY ROAD OR SIDEWALK OF MATERIAL THAT IS FROM THE PROJECT. THIS WILL BE DONE AT THE CLOSE OF EACH DAY OF WORK OR MORE FREQUENTLY AS MAY BE REQUIRED DUE TO FIELD CONDITIONS.
8. ALL STORM WATER INLETS, CATCH BASINS, AND MANHOLES INTENDED TO TAKE STORM WATER SHALL BE PROTECTED WITH FILTERS. DURING CONSTRUCTION, ALL SEDIMENT SHALL BE REMOVED. ALL FILTERS SHALL BE REPAIRED OR REPLACED AS NEEDED.
9. CONSTRUCTION ACCESS TO THE SITE SHALL BE ONLY AS SHOWN ON THE APPROVED PLANS. ALL VEHICLES LEAVING THE SITE, ONTO PUBLIC RIGHTS OF WAY, SHALL BE CLEANED TO PREVENT "TRACKING" OF MUD, DIRT OR OTHER DEBRIS.
10. ALL SEDIMENT AND DEBRIS SHALL BE KEPT FROM ENTERING THE STORM SEWER STRUCTURES OR IN THE RIGHT-OF-WAY AT ALL TIMES DURING CONSTRUCTION.
11. WARNING DEVICES TO INFORM AND PROTECT THE PUBLIC DURING ALL PHASES OF CONSTRUCTION ARE REQUIRED.
12. THE CONTRACTOR IS RESPONSIBLE FOR RETURNING ALL AREAS AFFECTED BY EQUIPMENT OR LABORERS TO EXISTING CONDITIONS. CONTRACTOR IS RESPONSIBLE FOR PROTECTING ALL NEW WORK UNTIL COMPLETION OF THIS CONTRACT.
13. THE CONTRACTOR SHALL INDEMNIFY THE OWNER, THE ENGINEER, AND OTHER AGENCIES FROM ALL LIABILITY INVOLVED IN THE CONSTRUCTION, INSTALLATION, AND TESTING OF THE WORK ON THIS PROJECT.
14. PROPOSED CONSTRUCTION MATERIALS SHALL BE SUBMITTED TO THE OWNER AND ENGINEER FOR APPROVAL IN ADVANCE OF MOBILIZATION. ANY DEVIATION FROM THE APPROVED CONSTRUCTION MATERIALS LIST MUST BE APPROVED BY THE ENGINEER IN WRITING.

**WATER SERVICE NOTES:**

1. ALL WATER MAINS, WATER SERVICE LINES, HYDRANTS, VALVES, AND OTHER DEVICES MUST CONFORM TO MUNICIPAL SPECIFICATIONS AND MUST BE APPROVED BY THE VILLAGE OF FORD HEIGHTS PRIOR TO INSTALLATION.
2. CONTRACTOR TO DETERMINE LOCATION OF LEAK IN A WATER MAIN. WATER MAIN LEAKS TO BE SEALED WITH A SLEEVE, UNLESS LEAK FOUND TO BE GREATER THAN TYPICAL SLEEVE LENGTH. AT THIS POINT, VERIFY LEAK REPAIR WITH ENGINEER.
3. FLUSH PRESSURE TEST AND CHLORINATE IN ACCORDANCE WITH STATE AND LOCAL STANDARDS.
4. FIELD VERIFY ALL DEPTHS, LOCATIONS, SIZES, AND MATERIALS PRIOR TO REMOVAL OR INSTALLATION.
5. ENSURE PROPER INSTALLATION AND FUNCTION OF BACKFLOW PREVENTION DEVICES AS NECESSARY.
6. ENSURE THERE ARE NO LEAKS AT ANY EXPOSED WATER LINE JUNCTION OR BEND, AND REPAIR ANY ENCOUNTERED.
7. FIRE HYDRANTS AND VAULTS ARE TO BE INSTALLED OR ADJUSTED TO GRADE.
8. CONNECTING PIPE UNDER FIRE HYDRANT SHALL BE CHECKED FOR LEAKS. IF PIPE IS LEAKING, REPLACE PIPE IN KIND.
9. ALL PAVEMENT SHALL BE REPLACED TO FULL REQUIRED DEPTH PER CITY OF CHICAGO AND CDOT STANDARDS.
10. ALL PAVEMENT REPLACEMENT / REPAIR SHALL BE FLUSH WITH EXISTING PAVEMENT USING PROPER COMPACTION TECHNIQS TO PREVENT LATER SETTLEMENT.
11. ALL PAVEMENT, CURB, AND GUTTER DAMAGED DUE TO CONSTRUCTION SHALL BE REPAIRED TO ORIGINAL CONDITION.
12. RESTORE ALL DISTURBED GRASSED AREAS AND SOIL TO ORIGINAL OR BETTER CONDITION.
13. TRAFFIC SHALL BE MAINTAINED WHILE WORKING IN THE STREET.
14. CONTRACTOR SHALL PROVIDE THRUST RESTRAINTS IN ACCORDANCE WITH THE SPECIFICATIONS. CONTRACTOR SHALL FURNISH AND INSTALL MECHANICAL JOINT THRUST RESTRAINT GLANDS AT ALL FITTINGS AND MECHANICAL JOINTS.
15. THE CONTRACTOR MUST VERIFY THE OPERATION OF EVERY VALVE NECESSARY FOR REQUIRED WATER MAIN SHUT DOWN FOR EACH PIPE SECTION. THE WORK MUST BE DONE UNDER DIRECT SUPERVISION OF A FORD HEIGHTS WATER DEPARTMENT REPRESENTATIVE AT LEAST 2 WEEKS PRIOR TO THE START OF THE JOB. A 48 HOUR ADVANCE NOTICE MUST BE GIVEN TO ALL CONSUMERS EFFECTED.
16. IN INSTANCES WHERE CHLORINATION IS TO BE DONE AGAINST ANY EXISTING VALVE, AT THE TIME THAT THE EXISTING WATER MAIN IS BREACHED FOR FINAL CONNECTION, THE CONTRACTOR SHALL VERIFY THAT THE EXISTING VALVES ARE IN GOOD OPERATING CONDITION AND DO NOT LEAK. ANY LEAKING VALVE SHOULD BE SHOULD BE BROUGHT TO ATTENTION OF THE FORD HEIGHTS WATER DEPARTMENT AND BE REPAIRED OR REPLACED PRIOR TO MAKING CONNECTION TO THE EXISTING WATER MAIN. THE VALVE SHALL REMAIN IN THE CLOSED POSITION UNTIL THE NEW WATER MAIN IS APPROVED FOR SERVICE.
17. ALL OPENINGS IN EXISTING WATER MAINS SHALL BE PLUGGED OR CAPPED WITH DUCTILE IRON FITTINGS UNTIL THE MAIN IS ABANDONED.
18. ALL VALVE BASINS SHALL BE CONSTRUCTED OF PRE-CAST REINFORCED CONCRETE UNLESS DIRECTED OTHERWISE BY THE FORD HEIGHTS WATER DEPARTMENT.
19. A TRANSITION SLEEVE SHALL BE USED IF A STANDARD MECHANICAL JOINT SLEEVE DOES NOT FIT TO MAKE CONNECTION OF THE NEW PIPE TO THE EXISTING PIPE. NO GRINDING OF THE EXISTING PIPE IS PERMITTED.
20. HOUSE DRAINS ARE NOT SHOWN ON THE DRAWINGS. THE CONTRACTOR SHALL LOCATE ALL HOUSE DRAINS WITHIN THE AREA OF EXCAVATION AND MAKE ADJUSTMENTS AND / OR REPAIRS.
21. WORK WITHIN STATE ROUTES WILL REQUIRE IDOT REGION ONE UTILITY PERMITS. THE CONTRACTOR IS RESPONSIBLE FOR SECURING ALL PERMITS AND OBTAINING PERFORMANCE BONDS. ALL WORK MUST BE IN ACCORDANCE WITH IDOT PERMIT REQUIREMENTS. QUESTIONS SHOULD BE DIRECTED TO IDOT REGION ONE UTILITIES COORDINATOR AT 847-705-4258.
22. ALL EXISTING WATER MAINS TO BE ABANDONED SHALL BE DONE SO IN ACCORDANCE WITH THE SPECIFICATIONS.
23. PIPES AND FITTINGS THE WILL NOT BE PRESSURE TESTED OR CHLORINATED SHALL BE SWABBED WITH CHLORINE SOLUTION DURING INSTALLATION AND FLUSHED PER BUREAU OF WATER QUALITY. EXTRA PRECAUTION SHALL BE USED TO PREVENT SOIL AND DEBRIS FROM ENTERING THE PIPE. UNTESTED PIPE SHALL BE INCORPORATED INTO THE FLUSHING ROUTINE WHEN POSSIBLE. OPERATING PRESSURE SHALL BE USED WHEN FEASIBLE TO VISUALLY INSPECT FOR LEAKS WHEN CONNECTING NEW PIPE TO THE EXISTING WATER SYSTEM. INSPECTIONS SHALL BE PERFORMED PRIOR TO BACKFILLING. COMPLY WITH ALL STANDARDS AND REQUIREMENTS OF THE BUREAU OF WATER QUALITY 312-744-8190.

**LEGEND**

-  ROW
-  LOT LINES
-  EXISTING FENCE LINE
-  EXISTING WATER LINE
-  EXISTING UTILITY POLE
-  EXISTING GUY WIRE
-  EXISTING LIGHT POLE
-  EXISTING SIGN
-  EXISTING FIRE HYDRANT
-  EXISTING WATER VALVE
-  REMOVE FIRE HYDRANT
-  REMOVE AND REPLACE FIRE HYDRANT
-  INLET PROTECTION

File Location: C:\Users\Emily.Eng\OneDrive - Antero Group\Projects\Village of Ford Heights\FH-2303 - Water System Improvements Phase I\DWG\Sheets\FH-2303-COV.dwg Plot Date: 3/19/2024 1:25 PM Last Saved By: EMILY.ENG



No.	DATE	REVISION DESCRIPTION

PREPARED FOR  
**VILLAGE OF FORD HEIGHTS**  
 1343 ELLIS AVENUE  
 FORD HEIGHTS, IL 60411



13TH STREET RESURFACING PROJECT  
 NOTES AND LEGEND  
 VILLAGE OF FORD HEIGHTS, COOK COUNTY, ILLINOIS

JOB NUMBER: FH-2303  
 DATE: 03-06-2024  
 SHEET: C-02

File Location: C:\Users\Emily.Eng\OneDrive - Antero Group\Projects\13th Street Milling\13th Street Milling.dwg Plot Date: 3/19/2024 1:26 PM Last Saved By: TALLUHAHTSHSAU

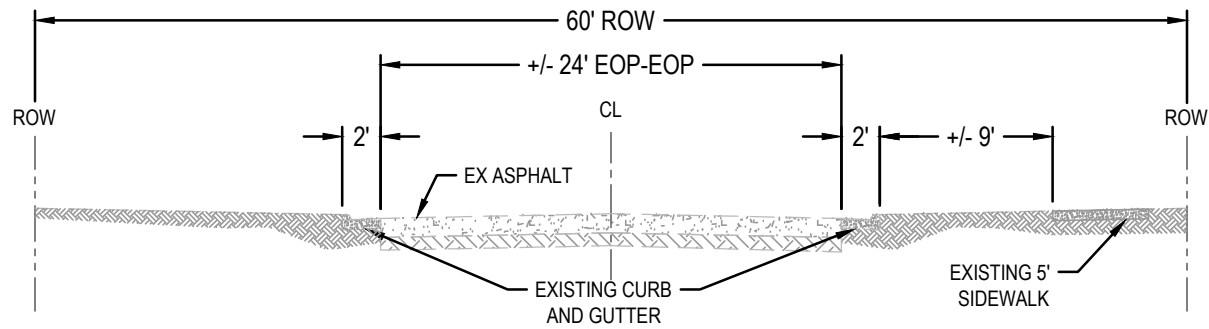

**EXISTING 13TH STREET SECTION**

STA: 10+00 TO 22+50  
N.T.S.

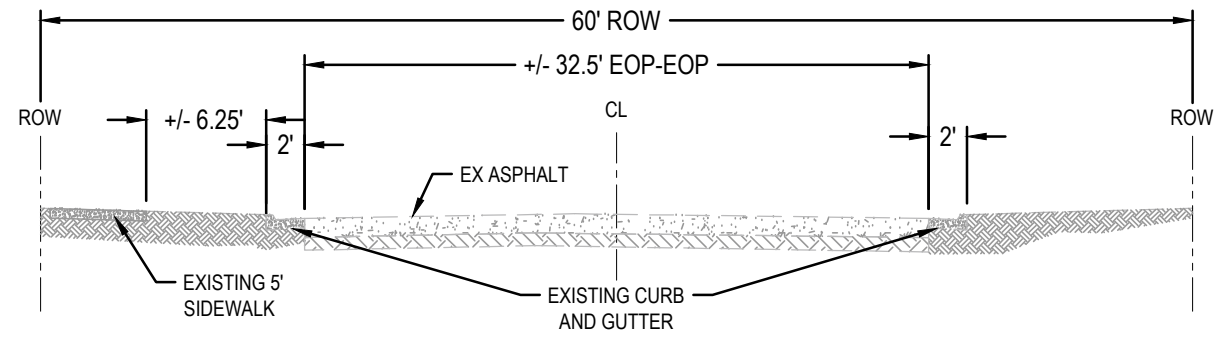

**EXISTING 13TH STREET SECTION**

STA: 23+25 TO 35+55  
N.T.S.

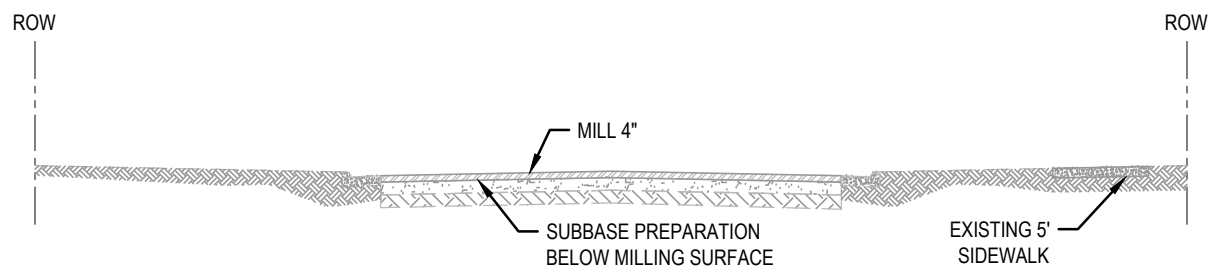

**13TH STREET MILLING SECTION**

STA: 10+00 TO 22+50  
N.T.S.

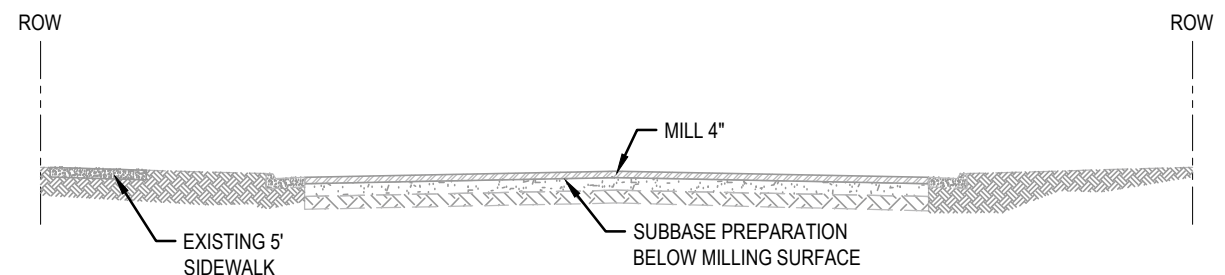

**13TH STREET MILLING SECTION**

STA: 23+25 TO 35+55  
N.T.S.

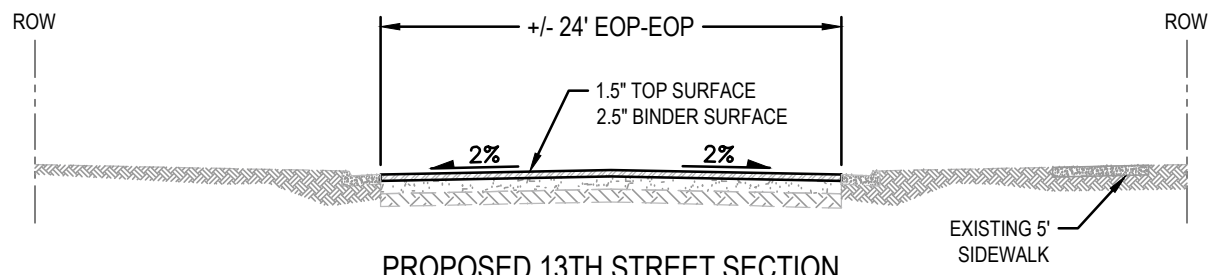

**PROPOSED 13TH STREET SECTION**

ASPHALT INSTALLATION STA: 10+00 TO 22+50  
N.T.S.

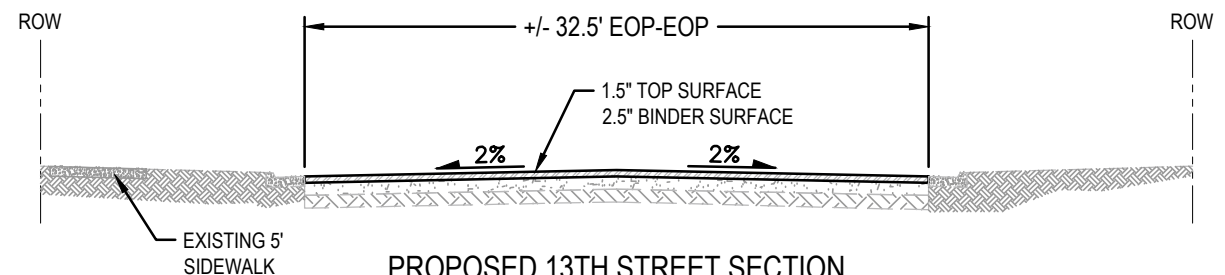

**PROPOSED 13TH STREET SECTION**

ASPHALT INSTALLATION STA: 23+25 TO 35+55  
N.T.S.

**NOTES:**

1. REMOVAL AND REPLACEMENT OF CURB AND GUTTER WILL BE MARKED IN THE FIELD PRIOR AS PART OF PRE-CONSTRUCTION MEETING WITH THE CONTRACTOR AND ENGINEER. PAVEMENT PATCHING WILL BE REQUIRED IN ALL AREAS OF CURB AND GUTTER REPLACEMENT.
2. IN AREAS OF NEW CURB, PARKWAY AREA IS TO BE REGRADED, IF NECESSARY, FOR POSITIVE DRAINAGE TOWARD THE ROADWAY.
3. ALL DISTURBED PARKWAY AREAS ARE TO BE FULLY RESTORED.
4. SELECT PAVEMENT PATCHING WILL BE REQUIRED AS PART OF THIS PROJECT AT THE DISCRETION OF THE ENGINEER.



No.	DATE	REVISION DESCRIPTION

PREPARED FOR  
**VILLAGE OF FORD HEIGHTS**  
1343 ELLIS AVENUE  
FORD HEIGHTS, IL 60411



**13TH STREET RESURFACING PROJECT**  
TYPICAL CROSS SECTIONS  
VILLAGE OF FORD HEIGHTS, COOK COUNTY, ILLINOIS

JOB NUMBER: FH-2303  
DATE: 03-06-2024  
SHEET: C-03

File Location: C:\Users\Emily.Eng\OneDrive - anterogroup.com\Documents - Antero Group\Projects\Village of Ford Heights\FH-2303 - Water System Improvements Phase II\DWG\Sheets\FH-2303-QUAT.dwg Plot Date: 3/19/2024 1:41 PM Last Saved By: EMILY.ENG

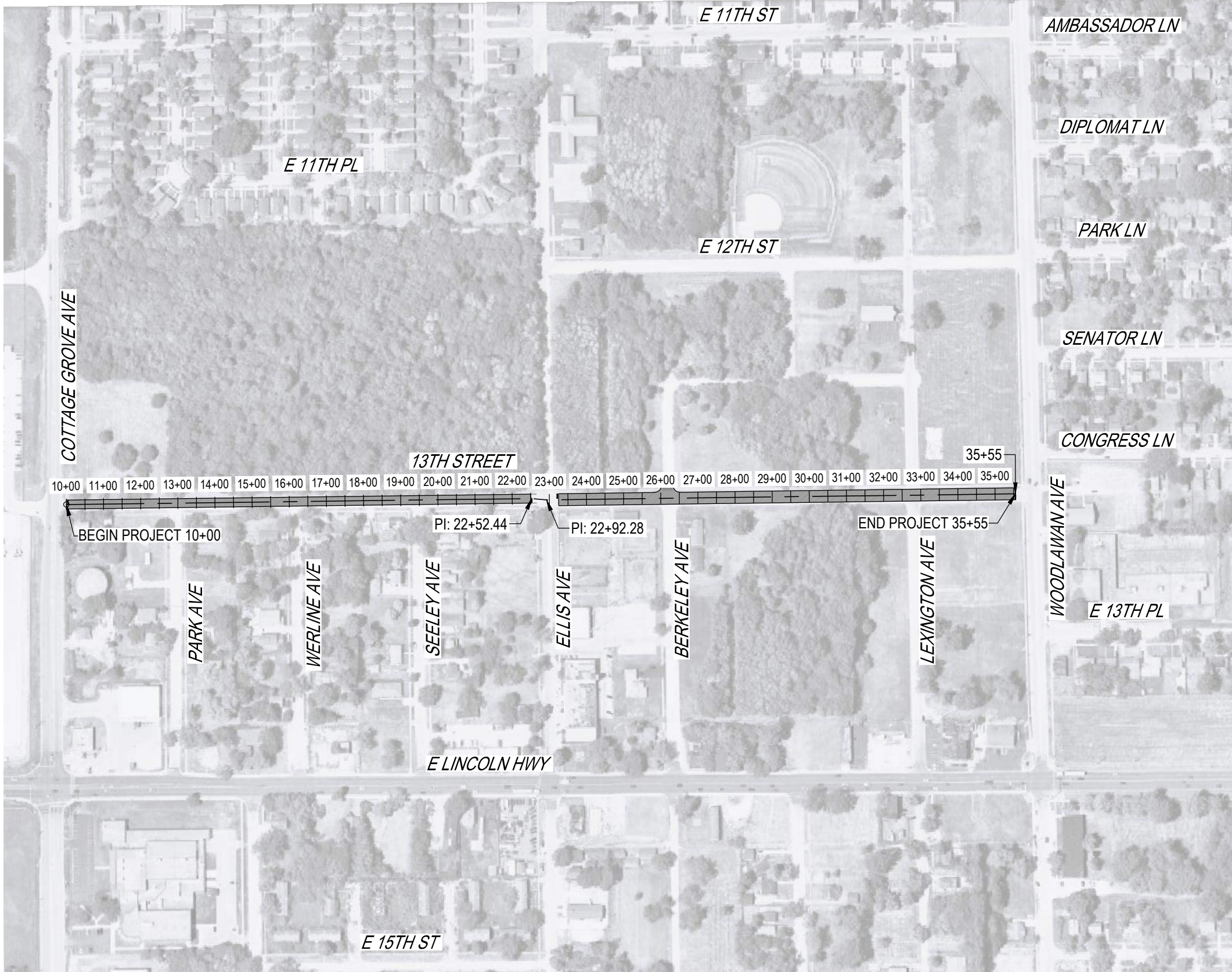

**NOTES:**

1. MILLING AND RESURFACING SHALL FOLLOW THE 13TH STREET TRAVEL LANES ACROSS SIDE STREETS UNLESS NOTED OTHERWISE ON THE CONSTRUCTION SHEETS.
2. ANY DAMAGE TO THE EXISTING CURB AND GUTTER WILL BE REPLACED IN-KIND AT THE CONTRACTOR'S EXPENSE.
3. ANY DAMAGE TO THE SIDEWALKS SHALL BE REPLACED IN-KIND AT THE CONTRACTOR'S EXPENSE.
4. INLET PROTECTION IS TO BE PLACED IN ALL INLETS WITHIN THE PROJECT CORRIDOR.
5. ALL STORM STRUCTURES ARE TO BE CLEANED OUT AFTER CONSTRUCTION.
6. POSITIVE DRAINAGE TOWARD EXISTING INLETS IS TO BE MAINTAINED THROUGHOUT THE MILLING AND RESURFACING CORRIDOR.

**DEMOLITION**

4" HOT MIX ASPHALT SURFACE REMOVAL	+/- 7,795 SQ.YDS.
REMOVE FIRE HYDRANT	4 EA.

**CONSTRUCTION**

HOT MIX ASPHALT SURFACE COURSE, MIX D, N <sub>50</sub> , 1.5"	325 CU.YDS. 658 TONS
HOT MIX ASPHALT BINDER COURSE IL-19.0, N <sub>50</sub> , 2.5" LIFT	542 CU.YDS. 1089 TONS
BITUMINOUS MATERIAL TACK COAT	779.5 GALLONS
BITUMINOUS MATERIAL PRIME COAT	2339 GALLONS
INLET PROTECTION	12 EA.
CLEAN OUT STORM STRUCTURE	12 EA.
2' WIDE THERMOPLASTIC, WHITE PAVEMENT MARKING	102 L.F.
REPLACE FIRE HYDRANT	2 EA.
REPAIR AND SLEEVE 6-IN WATER MAIN LEAK	1 EA.
REPAIR AND SLEEVE 10-IN WATER MAIN LEAK	1 EA.

**LEGEND**



MILLING AND RESURFACING

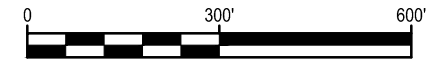

No.	DATE	REVISION DESCRIPTION

PREPARED FOR  
**VILLAGE OF FORD HEIGHTS**  
 1343 ELLIS AVENUE  
 FORD HEIGHTS, IL 60411



**13TH STREET RESURFACING PROJECT**  
 SUMMARY OF QUANTITIES  
 VILLAGE OF FORD HEIGHTS, COOK COUNTY, ILLINOIS

JOB NUMBER	FH-2303
DATE	03-06-2024
SHEET	C-04

File Location: C:\Users\Emily\_Eng\OneDrive - Antero Group\Projects\Village of Ford Heights\FH-2303\_Water System Improvements Phase IID\GIS\Sheets\FH-2303-SIGN\dwg Plot Date: 3/19/2024 1:25 PM Last Saved By: TALLUJAH SHISAU

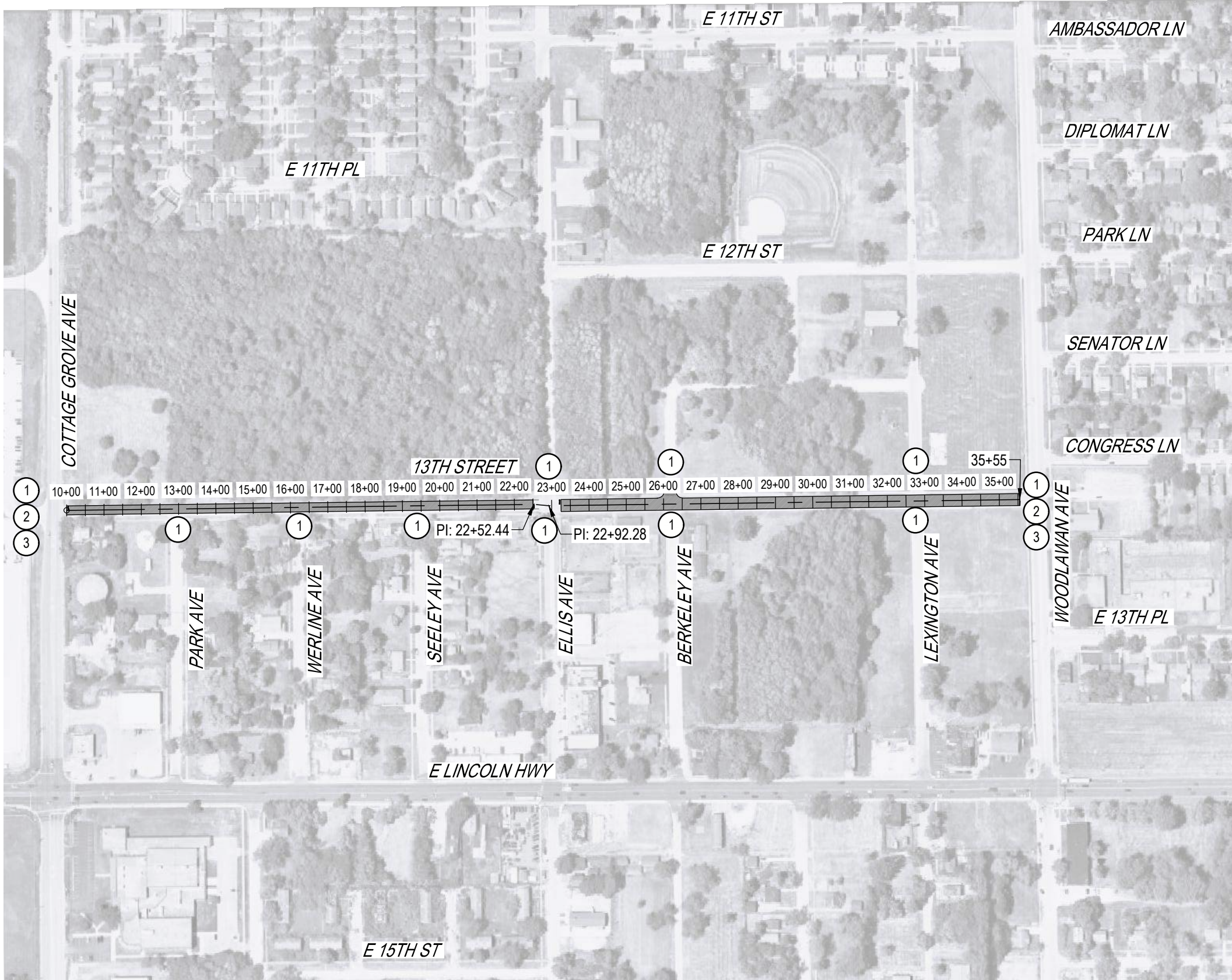

**NOTES:**

1. ALL STATIONING ON THIS PROJECT IS APPROXIMATE. ALL WORK LOCATIONS SHALL BE AS DIRECTED BY THE ENGINEER.
2. PLACEMENT OF SIGNS ARE TO BE PER MUTCD GUIDELINES.
3. CONTRACTOR TO SUBMIT A CONSTRUCTION SEQUENCING PLAN TO THE ENGINEER FOR REVIEW AND APPROVAL PRIOR TO MOBILIZATION.

**CONSTRUCTION SIGNS, TYPE "A"**

①	ROAD CONSTRUCTION AHEAD	
		W20-1Z
②	ROAD CLOSED TO THRU TRAFFIC	
		R11-4
③	END CONSTRUCTION	
		G20-2

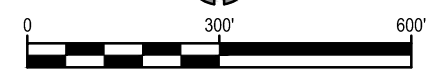

No.	DATE	REVISION DESCRIPTION

PREPARED FOR  
**VILLAGE OF FORD HEIGHTS**  
 1343 ELLIS AVENUE  
 FORD HEIGHTS, IL 60411



**13TH STREET RESURFACING PROJECT**  
 SIGNAGE PLAN  
 VILLAGE OF FORD HEIGHTS, COOK COUNTY, ILLINOIS

JOB NUMBER: FH-2303  
 DATE: 03-06-2024  
 SHEET: C-05

File Location: C:\Users\Emily.Eng\OneDrive - anterogroup.com\Documents - Antero Group\Projects\Village of Ford Heights\FH-2303\_Water System Improvements Phase IID\GIS\Sheets\FH-2303-KEY.Mxd; Plot Date: 3/19/2024, 1:25 PM; Last Saved By: TALLUJAH SHHAU

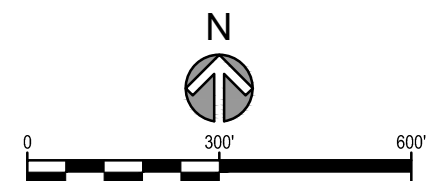
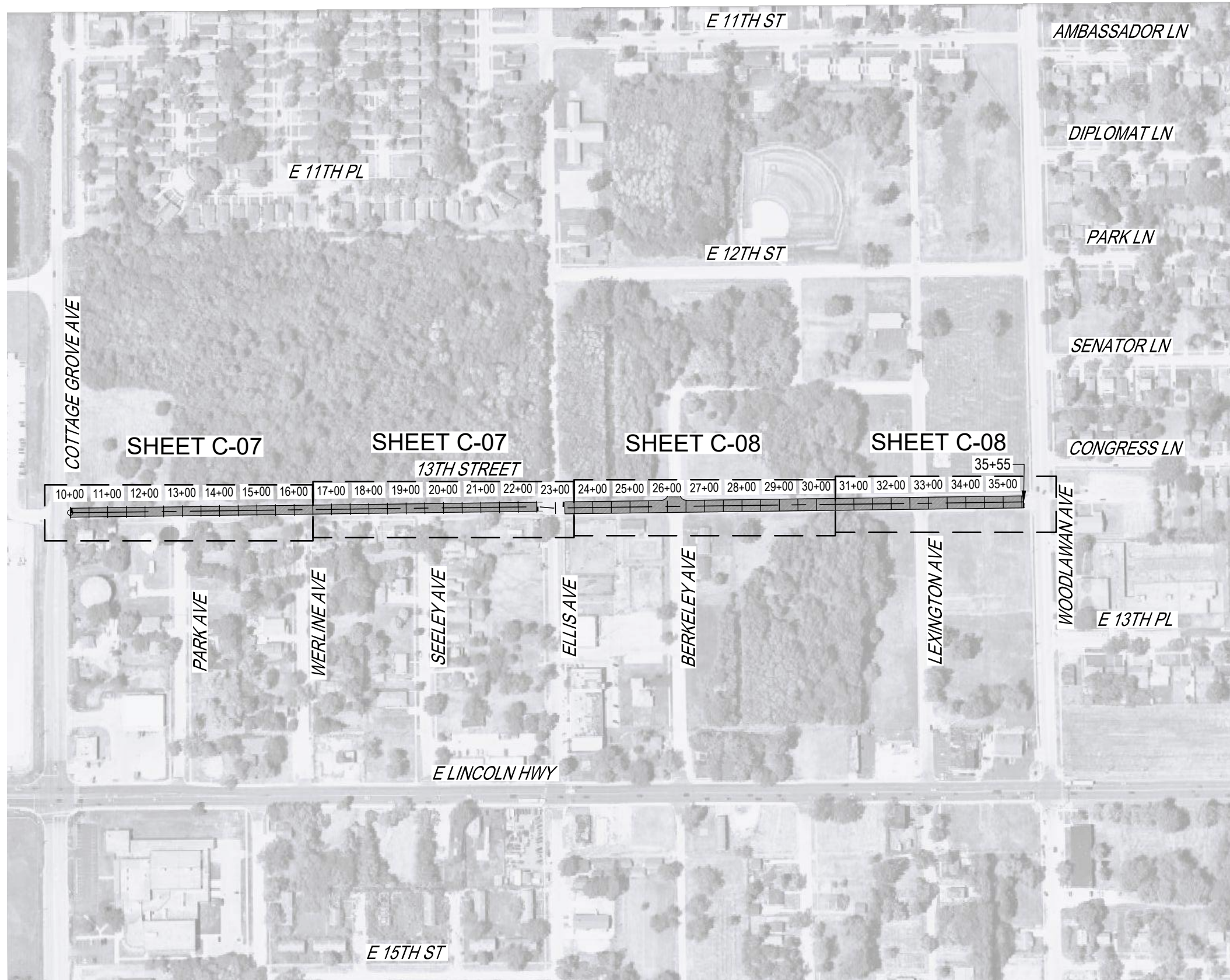

No.	DATE	REVISION DESCRIPTION

PREPARED FOR  
**VILLAGE OF FORD HEIGHTS**  
 1343 ELLIS AVENUE  
 FORD HEIGHTS, IL 60411



**13TH STREET RESURFACING PROJECT**  
 KEY MAP  
 VILLAGE OF FORD HEIGHTS, COOK COUNTY, ILLINOIS

JOB NUMBER: FH-2303  
 DATE: 03-06-2024  
 SHEET: C-06

File Location: C:\Users\Emily\OneDrive - Antero Group\Projects\Village of Ford Heights\FH-2303\_Water System Improvements Phase II\DWG\Sheets\FH-2303-STR-P-PLAN.dwg Plot Date: 3/19/2024 1:26 PM Last Saved By: EMILY ENG

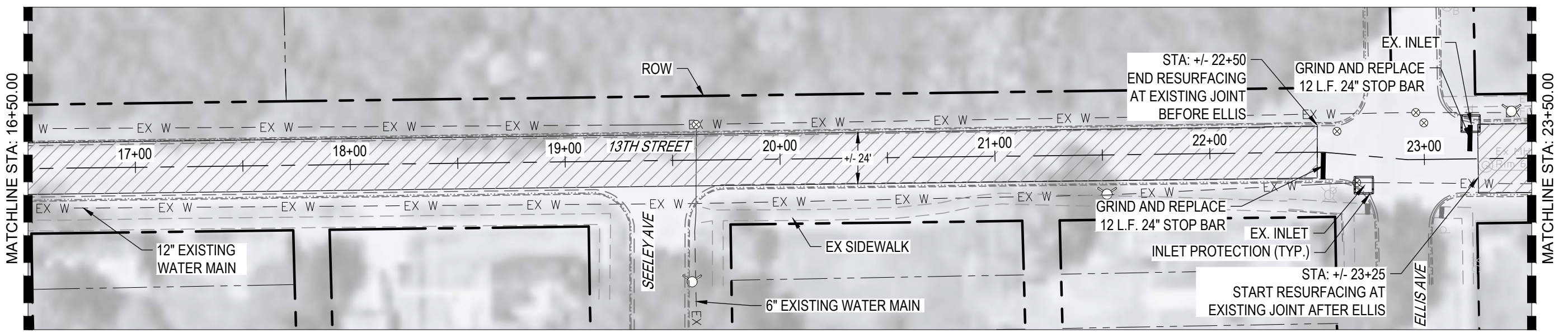
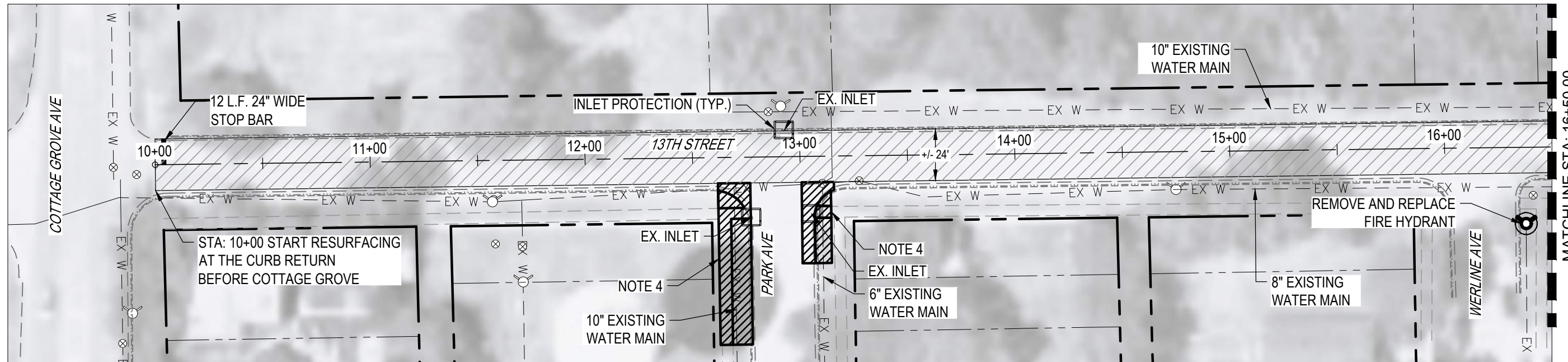

**NOTES:**

1. MILLING AND RESURFACING SHALL FOLLOW THE 13TH STREET TRAVEL LANES ACROSS SIDE STREETS UNLESS NOTED OTHERWISE ON THE CONSTRUCTION SHEETS.
2. ANY DAMAGE TO THE CURB AND GUTTER SHALL BE REPLACED IN-KIND AT THE CONTRACTOR'S EXPENSE.
3. POSITIVE DRAINAGE TOWARD EXISTING INLETS IS TO BE MAINTAINED THROUGHOUT THE MILLING AND RESURFACING CORRIDOR.
4. CONTRACTOR SHALL LOCATE THE WATER LEAKS IN THE AREAS INDICATED ADJACENT TO PARK AVENUE. ONCE LOCATED, CONTRACTOR SHALL MINIMIZE THE EXTENT OF EXCAVATION. WATER MAIN REPAIR SHALL BE PERFORMED PER THE NOTES ON SHEET C-02. ALL EXISTING FEATURES (SUCH AS SIDEWALK, GRASSED AREAS, PAVEMENT, AND CURB & GUTTER) SHALL BE REPLACED IN-KIND.

**LEGEND**

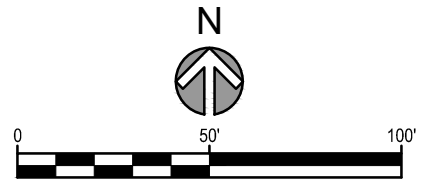
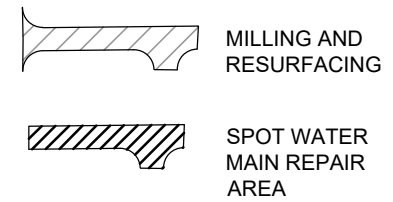

No.	DATE	REVISION DESCRIPTION

PREPARED FOR  
**VILLAGE OF FORD HEIGHTS**  
 1343 ELLIS AVENUE  
 FORD HEIGHTS, IL 60411



**13TH STREET RESURFACING PROJECT**  
 CONSTRUCTION PLAN STA 10+00 THRU 23+50  
 VILLAGE OF FORD HEIGHTS, COOK COUNTY, ILLINOIS

JOB NUMBER: FH-2303  
 DATE: 03-06-2024  
 SHEET: **C-07**

File Location: C:\Users\Emily\OneDrive - Antero Group\Projects\Village of Ford Heights\FH-2303 - Water System Improvements Phase I\DWG\Sheets\FH-2303-STR-PLAN.dwg Plot Date: 3/19/2024 1:40 PM Last Saved By: EMILY ENG

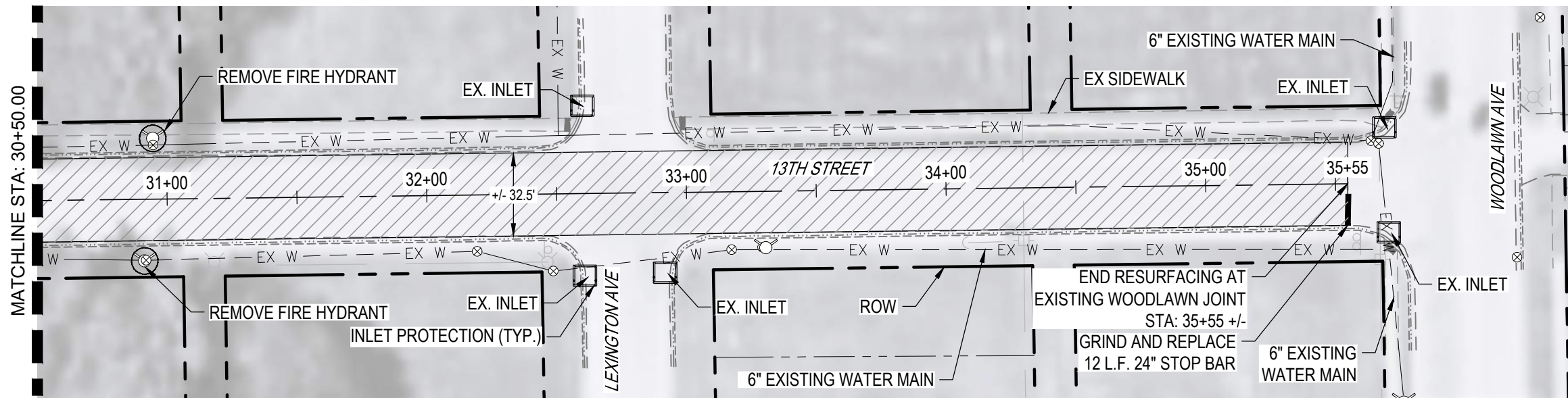
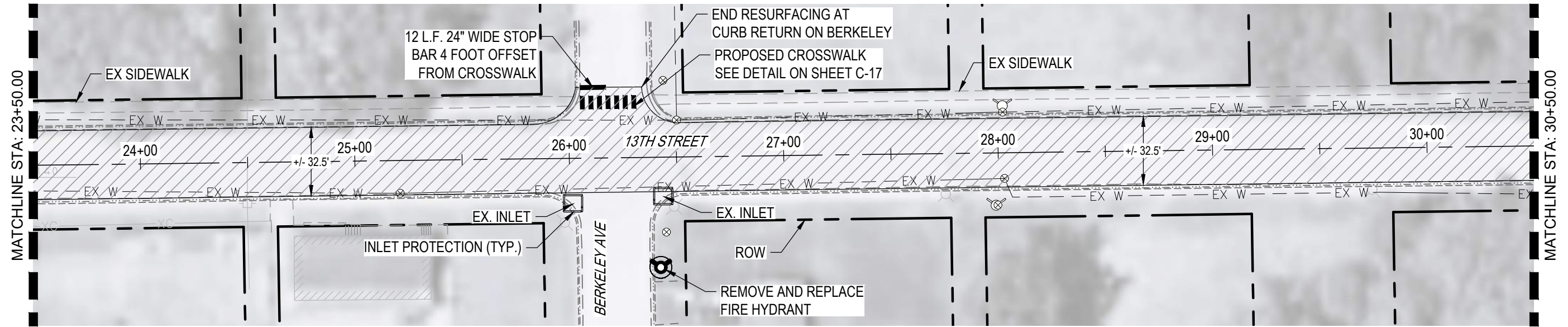

**NOTES:**

1. MILLING AND RESURFACING SHALL FOLLOW THE 13TH STREET TRAVEL LANES ACROSS SIDE STREETS UNLESS NOTED OTHERWISE ON THE CONSTRUCTION SHEETS.
2. ANY DAMAGE TO THE CURB AND GUTTER SHALL BE REPLACED IN-KIND AT THE CONTRACTOR'S EXPENSE.
3. POSITIVE DRAINAGE TOWARD EXISTING INLETS IS TO BE MAINTAINED THROUGHOUT THE MILLING AND RESURFACING CORRIDOR.

**LEGEND**

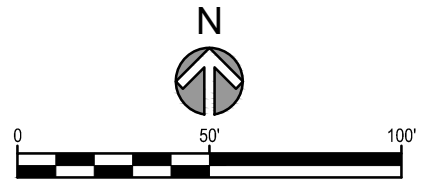

No.	DATE	REVISION DESCRIPTION

PREPARED FOR  
**VILLAGE OF FORD HEIGHTS**  
 1343 ELLIS AVENUE  
 FORD HEIGHTS, IL 60411



**13TH STREET RESURFACING PROJECT**  
 CONSTRUCTION PLAN STA 23+50 THRU 35+55  
 VILLAGE OF FORD HEIGHTS, COOK COUNTY, ILLINOIS

JOB NUMBER: FH-2303  
 DATE: 03-06-2024  
 SHEET: C-08

**GENERAL NOTES**

1. LOCATION OF UTILITIES AND PROPERTY LINES ARE FROM THE BEST INFORMATION AVAILABLE. EXACT LOCATION AND COMPLETENESS ARE NOT GUARANTEED.
2. THE CONTRACTOR MUST VERIFY THE LOCATION OF UNDERGROUND UTILITIES WITH THE UTILITY OWNERS PRIOR TO DOING ANY WORK IN THE VICINITY. THE CONTRACTOR MUST COMPLY WITH REQUIREMENTS OF UTILITY OWNERS REGARDING NOTICE OF WORK AND PROTECTION OF UTILITIES. THE CONTRACTOR MUST COMPLY WITH THE CITY OF CHICAGO, DEPARTMENT OF TRANSPORTATION DAMAGE PREVENTION PROTOCOL CITY INFRASTRUCTURE DEPARTMENTS. ALL UTILITIES MUST BE NOTIFIED AT LEAST 48 HOURS BEFORE CONSTRUCTION. (CALL DIGGER 312-744-7000).
3. TEST PITS MUST BE EXCAVATED IN ADVANCE OF PIPELINE CONSTRUCTION IN ORDER TO CONFIRM DEPTH AND LOCATION OF EXISTING UTILITIES AND WHEN DIRECTED BY THE DEPARTMENT MANAGER. NO ADDITIONAL PAYMENT WILL BE MADE FOR TEST PIT EXCAVATION.
4. IF ANY PUBLIC OR PRIVATE UTILITIES CROSS THE WATER MAIN TRENCH AND MUST REMAIN IN PLACE. THE CONTRACTOR MUST PROTECT SAID UTILITY IN CONFORMANCE WITH THE SPECIFICATIONS OR AS DIRECTED BY THE COMMISSIONER.
5. PROVIDE EROSION CONTROL IN ACCORDANCE WITH THE SPECIFICATIONS.
6. FITTINGS AND THEIR LOCATIONS INDICATED ON THE DRAWINGS ARE TENTATIVE. THE CONTRACTOR MUST COMPLETE THE INSTALLATION WITH THE NECESSARY FITTINGS DICTATED BY FIELD CONDITIONS. NO ADDITIONAL PAYMENT WILL BE MADE FOR DEVIATIONS FROM THE INDICATED FITTINGS.
7. WORK INDICATED ON THE PLANS AND NOT REFERENCED TO A BID ITEM IS CONSIDERED INCIDENTAL TO THE WORK TO WHICH IT APPLIES AND NO ADDITIONAL COMPENSATION WILL BE ALLOWED.
8. WATER MAIN AND FITTINGS LOCATIONS SHOWN ON THE DRAWINGS FOR THE NEW WATER MAINS AND APPURTENANCES MAY BE CHANGED BY THE COMMISSIONER DUE TO FIELD CONDITIONS. NO ADDITIONAL COMPENSATION WILL BE ALLOWED FOR SUCH CHANGES. UNLESS PREVIOUSLY APPROVED BY THE COMMISSIONER.
9. THE CONTRACTOR MUST PROVIDE THRUST RESTRAINTS IN ACCORDANCE WITH THE SPECIFICATIONS. THE CONTRACTOR MUST FURNISH AND INSTALL MECHANICAL JOINT THRUST RESTRAINT GLANDS AT ALL FITTINGS AND MECHANICAL JOINTS.
10. THE CONTRACTOR MUST VERIFY THE OPERATION OF EVERY VALVE NECESSARY FOR THE REQUIRED WATER MAIN SHUT DOWN FOR EACH PIPE SECTION. FOR VALVES OR WATER MAINS UNDER 16-INCHES IN DIAMETER, THE WORK MUST BE DONE UNDER THE DIRECT SUPERVISION OF A DEPARTMENT REPRESENTATIVE AT LEAST 2 WEEKS PRIOR TO THE START OF THE JOB. A 24 HOUR ADVANCE NOTICE MUST BE GIVEN TO ALL CONSUMERS EFFECTED AND THE BUREAU OF OPERATIONS AND DISTRIBUTION. THE OPERATION OF ALL VALVES 16-INCHES IN DIAMETER AND LARGER MUST BE PERFORMED BY CITY FORCES PURSUANT TO A 72 HOUR ADVANCE NOTIFICATION TO THE DEPARTMENT. ANY VALVE FOUND NOT OPERABLE WILL BE REPAIRED OR REPLACED BY THE DEPARTMENT UNLESS DIRECTED OTHERWISE BY THE COMMISSIONER.
11. IN INSTANCES WHERE CHLORINATION IS TO BE DONE AGAINST ANY EXISTING VALVE, AT THE TIME THAT THE EXISTING WATER MAIN IS BREACHED FOR FINAL CONNECTION, THE CONTRACTOR IS TO VERIFY THAT THE EXISTING VALVES ARE IN GOOD OPERATING CONDITION AND DO NOT LEAK. ANY LEAKING VALVE SHOULD BE BROUGHT TO THE COMMISSIONERS' ATTENTION AND BE REPAIRED OR REPLACED PRIOR TO MAKING PIPE CONNECTIONS TO THE EXISTING WATER MAIN. THE VALVE SHOULD REMAIN IN THE CLOSED POSITION UNTIL THE NEW WATER MAIN IS APPROVED FOR SERVICE.

**GENERAL NOTES**

**WATER MAIN CONTRACTS**

REV:04.07

D-20  
SHT. 1 OF 2

**GENERAL NOTES (CONTINUED)**

12. ALL OPENINGS IN EXISTING WATER MAINS MUST BE PLUGGED OR CAPPED WITH DUCTILE IRON FITTINGS UNTIL THE MAIN IS ABANDONED.
13. ALL VALVE BASINS MUST BE CONSTRUCTED OF PRE-CAST REINFORCED CONCRETE UNLESS DIRECTED OTHERWISE BY THE COMMISSIONER.
14. NOTES INDICATING S.N.L., E.W.L., ETC., MEAN SOUTH OF THE NORTH PROPERTY LINE, EAST OF THE WEST PROPERTY LINE, ETC. AND ARE MEASURED FROM THE NEAREST STREET.
15. IF A STANDARD MECHANICAL JOINT SLEEVE DOES NOT FIT TO MAKE CONNECTION OF THE NEW PIPE TO THE EXISTING PIPE, A TRANSITION SLEEVE MUST BE USED. NO GRINDING OF THE EXISTING PIPE IS PERMITTED.
16. BURIED STREET CAR TRACKS ARE SHOWN FOR INFORMATIONAL PURPOSES ONLY. EXACT LOCATIONS AND DIMENSIONS ARE UNKNOWN UNLESS NOTED OTHERWISE. CAUTION SHOULD BE EXERCISED WHEN EXCAVATING IN THE STREETS CONTAINING BURIED STREET CAR TRACKS. BURIED TRACKS AND CABLES MAY BE USED FOR ELECTRICAL GROUNDING BY THE CHICAGO TRANSIT AUTHORITY OR MEMBERS OF THE CHICAGO AREA JOINT ELECTROLYSIS COMMITTEE STANDARDS. ELECTRICAL CONDUCTIVITY MUST BE MAINTAINED.
17. HOUSE DRAINS ARE NOT SHOWN ON THE DRAWINGS. THE CONTRACTOR MUST LOCATE ALL HOUSE DRAINS WITHIN THE AREA OF EXCAVATION AND MAKE ADJUSTMENTS AND/OR REPAIRS.
18. THE DEPARTMENT WILL PROVIDE THE NECESSARY I.E.P.A. WATER MAIN CONSTRUCTION PERMITS FOR THIS CONTRACT.
19. WORK WITHIN STATE ROUTES ARE NOTED ON THE DRAWINGS AND WILL REQUIRE I.D.O.T. REGION 1. UTILITY PERMITS. THE CONTRACTOR IS RESPONSIBLE FOR SECURING ALL PERMITS, INITIATED BY THE DEPARTMENT AND OBTAINING PERFORMANCE BONDS. ALL WORK MUST BE IN ACCORDANCE WITH I.D.O.T. PERMIT REQUIREMENTS. QUESTIONS SHOULD BE DIRECTED TO: I.D.O.T REGION ONE UTILITIES COORDINATOR AT (847) 705-4258.
20. ABANDON EXISTING WATER MAINS IN ACCORDANCE WITH THE SPECIFICATIONS.
21. SWAB PIPE AND FITTINGS THAT WILL NOT BE PRESSURE TESTED OR CHLORINATED WITH CHLORINE SOLUTION DURING INSTALLATION AND USE EXTRA PRECAUTION TO PREVENT SOIL AND DEBRIS FROM ENTERING THE PIPE. INCORPORATE UNTESTED PIPE INTO THE FLUSHING ROUTINE WHEN POSSIBLE. WHEN CONNECTING NEW PIPE TO THE EXISTING WATER SYSTEM, USE OPERATING PRESSURE TO VISUALLY INSPECT FOR LEAKS. WHEN FEASIBLE, PERFORM INSPECTION PRIOR TO BACKFILLING. COMPLY WITH ALL STANDARDS AND REQUIREMENTS OF THE BUREAU OF WATER QUALITY (312) 744-8190.

**GENERAL NOTES**

**WATER MAIN CONTRACTS**

REV:04.07

D-20  
SHT. 2 OF 2

File Location: C:\Users\Emily.Eng\OneDrive - Antero Group\Projects\Village of Ford Heights\FH-2303-Water System Improvements Phase I\DWG\Sheets\FH-2303-DET-1.dwg Plot Date: 3/19/2024 1:28 PM Last Saved By: EMILY ENG



Know what's below.  
Call before you dig.

No.	DATE	REVISION DESCRIPTION

PREPARED FOR

VILLAGE OF FORD HEIGHTS  
1343 ELLIS AVENUE  
FORD HEIGHTS, IL 60411



13TH STREET RESURFACING PROJECT

STANDARDS AND DETAILS

VILLAGE OF FORD HEIGHTS, COOK COUNTY, ILLINOIS

JOB NUMBER  
FH-2303

DATE  
03-06-2024

SHEET  
C-09



File Location: C:\Users\Emily.Eng\OneDrive - Antero Group\Projects\Village of Ford Heights\FH-2303\_Water System Improvements Phase II\DWG\Sheets\FH-2303-DET\dwg Plot Date: 3/19/2024 1:28 PM Last Saved By: EMILY.ENG

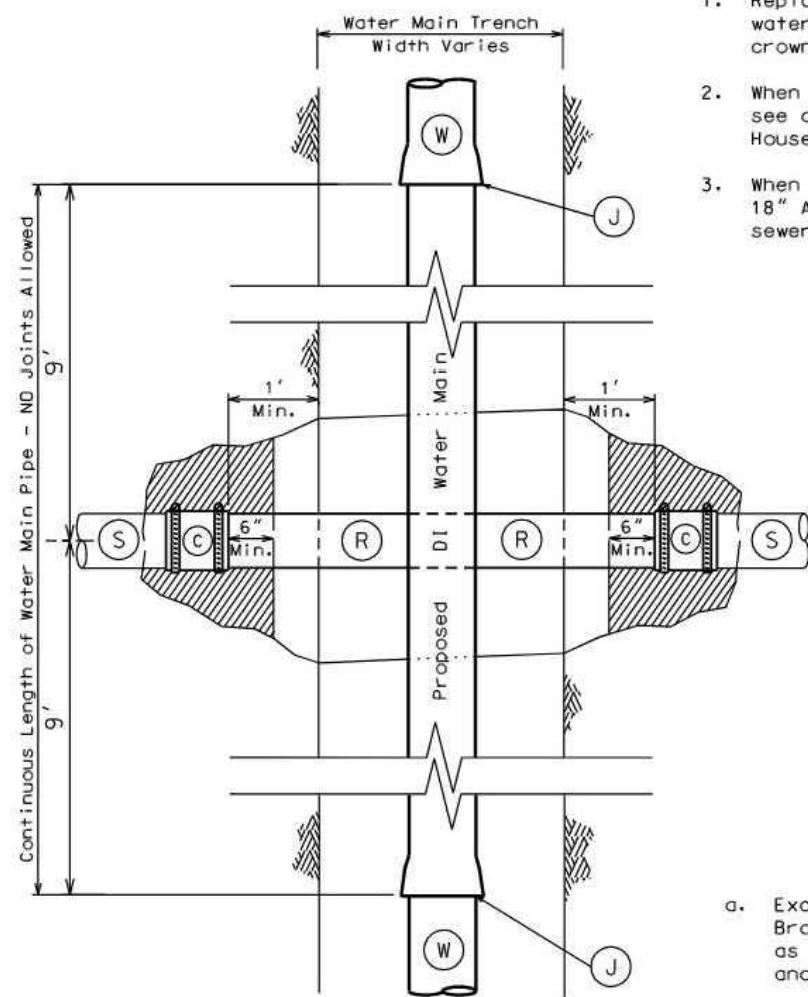

PLAN  
No Scale

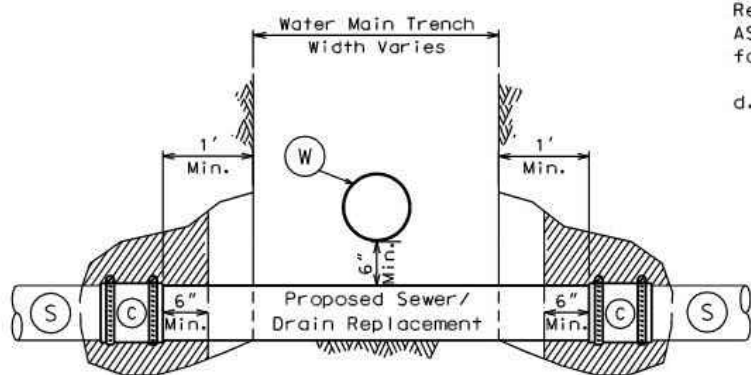

PROFILE THROUGH SEWER/DRAIN  
No Scale

**WATER MAINS CROSSING OVER  
SEWERS & HOUSE DRAINS**

Rev:11.07

D-19  
SHT. 1 OF 2

**GENERAL NOTES**

1. Replace the sewer/drain when the invert of the water main is LESS than 18" ABOVE the crown of the sewer/drain.
2. When a water main crosses UNDER a sewer/drain, see detail "Water Mains Crossing Under Sewers & House Drains."
3. When the invert of the water main is MORE than 18" ABOVE the crown of the sewer/drain, no sewer/drain replacement is required.

**KEY TO SYMBOLS**

- (W) Proposed DI Water Main
- (J) Proposed DI Water Main Joint (Continuous Pipe Between Joints)
- (S) Existing Sewer or House Drain
- (R) Proposed Sewer/Drain Replacement
- (C) Proposed ASTM C1173 Flexible Transition Coupling for Sewer Piping
- [Hatched] Proposed Bentonite Seal
- [Wavy] Undisturbed Soil

**SEWER/DRAIN REPLACEMENT NOTES**

- a. Excavate as needed to replace sewer/drain. Brace and shore trenches and excavations as needed to provide safe working conditions and comply with applicable requirements.
- b. Cut existing sewer/drain to remove section to be replaced; breaking or cracking is not allowed.
- c. Replace the sewer/drain with a continuous length of ductile iron pipe, the same size as the sewer/drain, cut to fit. Reconnect the sewer/drain with ASTM C1173 Flexible Transition Couplings for Sewer Pipe.
- d. Encase the couplings in medium bentonite chips (1/4" - 3/8") mixed with enough clean water to form a stiff clay. Pack the excavations surrounding the couplings to seal off leaks.
- e. Center a length of water main pipe (18' typically) over the sewer/drain crossing.
- f. Except where bentonite seals are shown, backfill using typical standards.
- g. Comply with IL EPA requirements (modified and approved by IL EPA November 13, 2007).

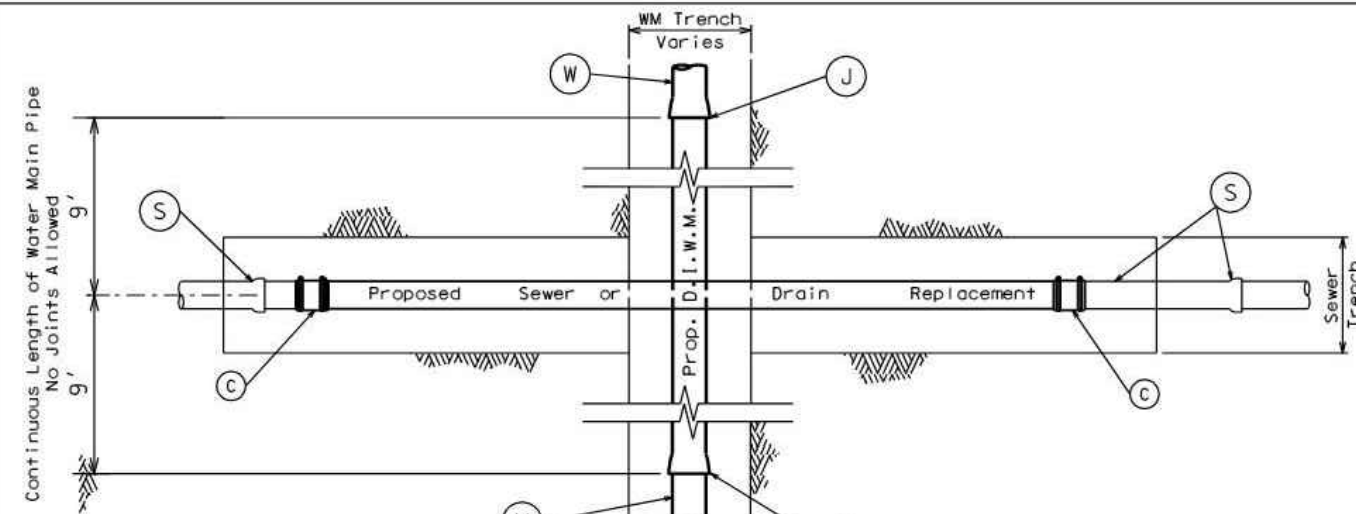

PLAN  
No Scale

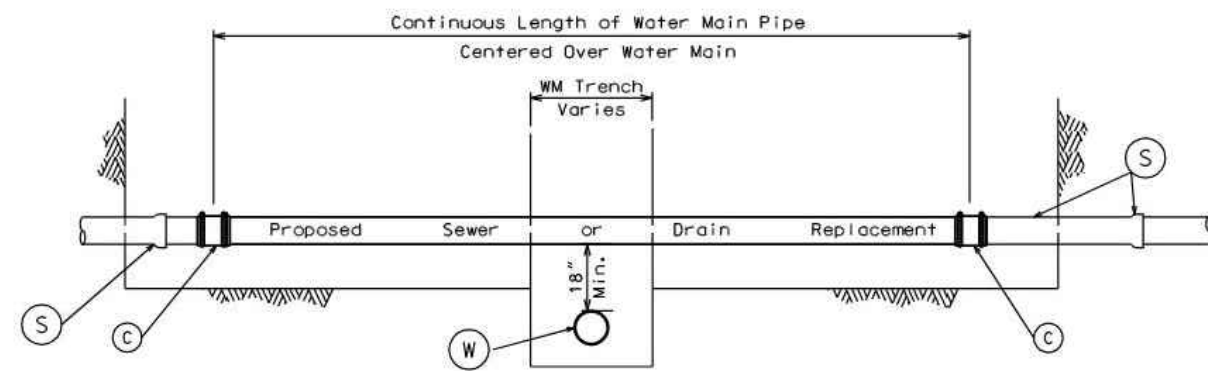

PROFILE THROUGH SEWER/DRAIN  
No Scale

**WATER MAINS CROSSING UNDER  
SEWERS & HOUSE DRAINS**

REV:11.07

D-19  
SHT. 2 OF 2

**GENERAL NOTES**

1. Replace the sewer/drain in all cases when a water main crosses UNDER the sewer/drain.
2. When a water main crosses OVER a sewer/drain, see detail "Water Mains Crossing Over Sewers & House Drains."

**KEY TO SYMBOLS**

- (W) Proposed DI Water Main
- (J) Proposed DI Water Main Joint (Continuous Pipe Between Joints)
- (S) Existing Sewer or House Drain
- (R) Proposed Sewer/Drain Replacement
- (C) Proposed ASTM C1173 Flexible Transition Coupling for Sewer Piping
- [Hatched] Proposed Bentonite Seal
- [Wavy] Undisturbed Soil

**SEWER/DRAIN REPLACEMENT NOTES**

- a. Minimum clearance between the crown of the water main and the invert of the sewer/drain is 18".
- b. Excavate as needed to replace sewer/drain. Brace and shore trenches and excavations as needed to provide safe working conditions and comply with applicable requirements.
- c. Cut existing sewer/drain to remove section to be replaced; breaking or cracking is not allowed.
- d. Replace the sewer/drain with a continuous length of ductile iron pipe, the same size as the sewer/drain, cut to fit. Reconnect the sewer/drain with ASTM C1173 Flexible Transition Couplings for Sewer Pipe.
- e. Center a length of water main pipe (18' typically) under the sewer/drain crossing.
- f. Backfill using typical standards.
- g. Comply with IL EPA requirements.



No.	DATE	REVISION DESCRIPTION

PREPARED FOR  
VILLAGE OF FORD HEIGHTS  
1343 ELLIS AVENUE  
FORD HEIGHTS, IL 60411



13TH STREET RESURFACING PROJECT  
STANDARDS AND DETAILS  
VILLAGE OF FORD HEIGHTS, COOK COUNTY, ILLINOIS

JOB NUMBER: FH-2303  
DATE: 03-06-2024  
SHEET: C-10

File Location: C:\Users\Emily\OneDrive - Antero Group\Projects\Documents - Antero Group\Projects\13th Street Resurfacing Project\FH-2303\Drawings\FH-2303-DET-1.dwg Plot Date: 3/19/2024 1:28 PM Last Saved By: EMILY ENG

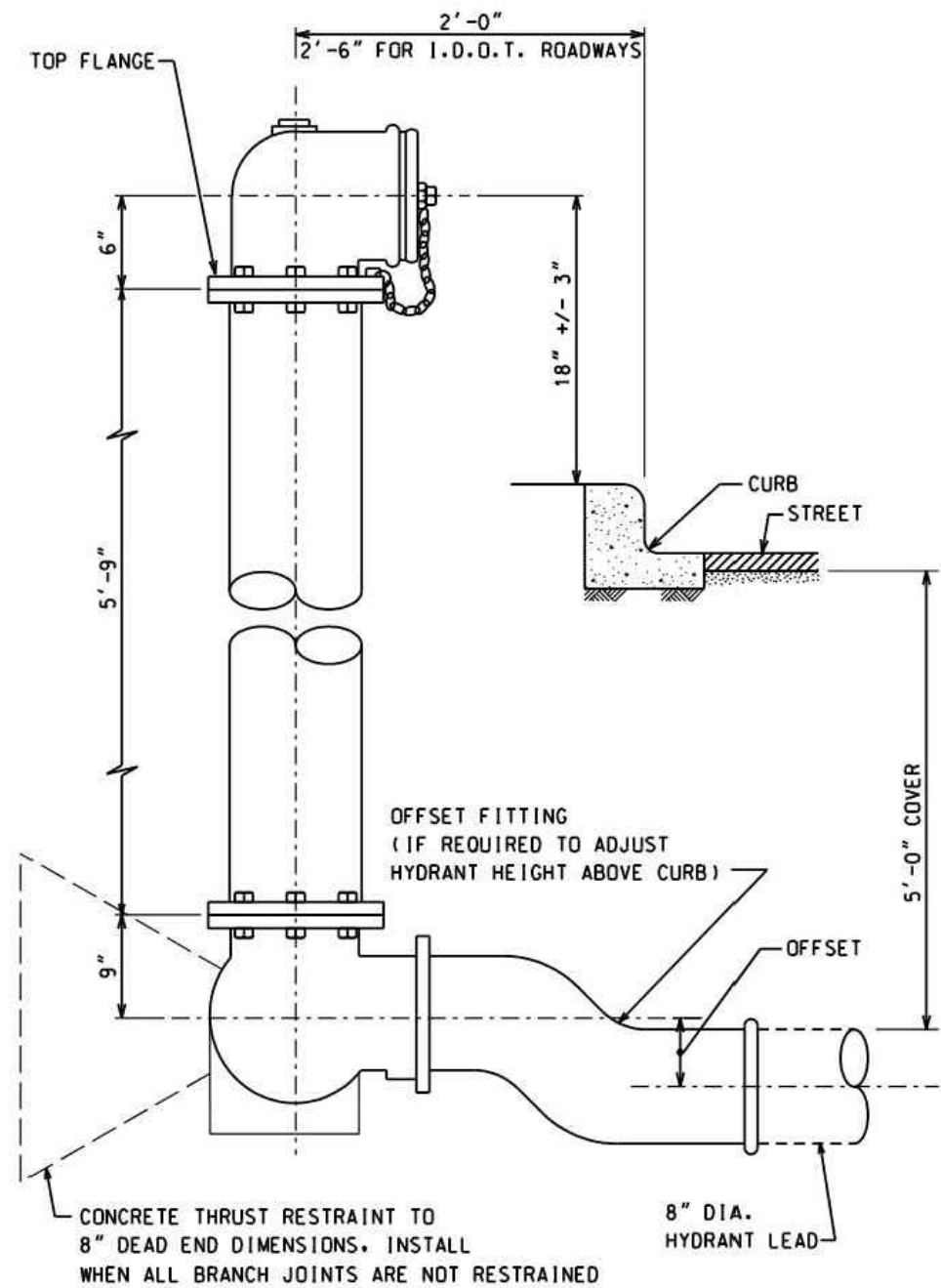

**NOTE:**

1. SEE FIRE HYDRANT DRAIN DETAILS.
2. ALL BURIED DUCTILE IRON HYDRANT COMPONENTS MUST BE WRAPPED IN POLYETHYLENE ENCASEMENT.
3. SEE DETAIL D-5 FOR FIRE HYDRANT DRAIN ASSEMBLY

**FIRE HYDRANT SETTING DETAIL**

D-2

REV:04.09



No.	DATE	REVISION DESCRIPTION

PREPARED FOR  
**VILLAGE OF FORD HEIGHTS**  
 1343 ELLIS AVENUE  
 FORD HEIGHTS, IL 60411



13TH STREET RESURFACING PROJECT

STANDARDS AND DETAILS

VILLAGE OF FORD HEIGHTS, COOK COUNTY, ILLINOIS

JOB NUMBER  
FH-2303

DATE  
03-06-2024

SHEET  
C-11

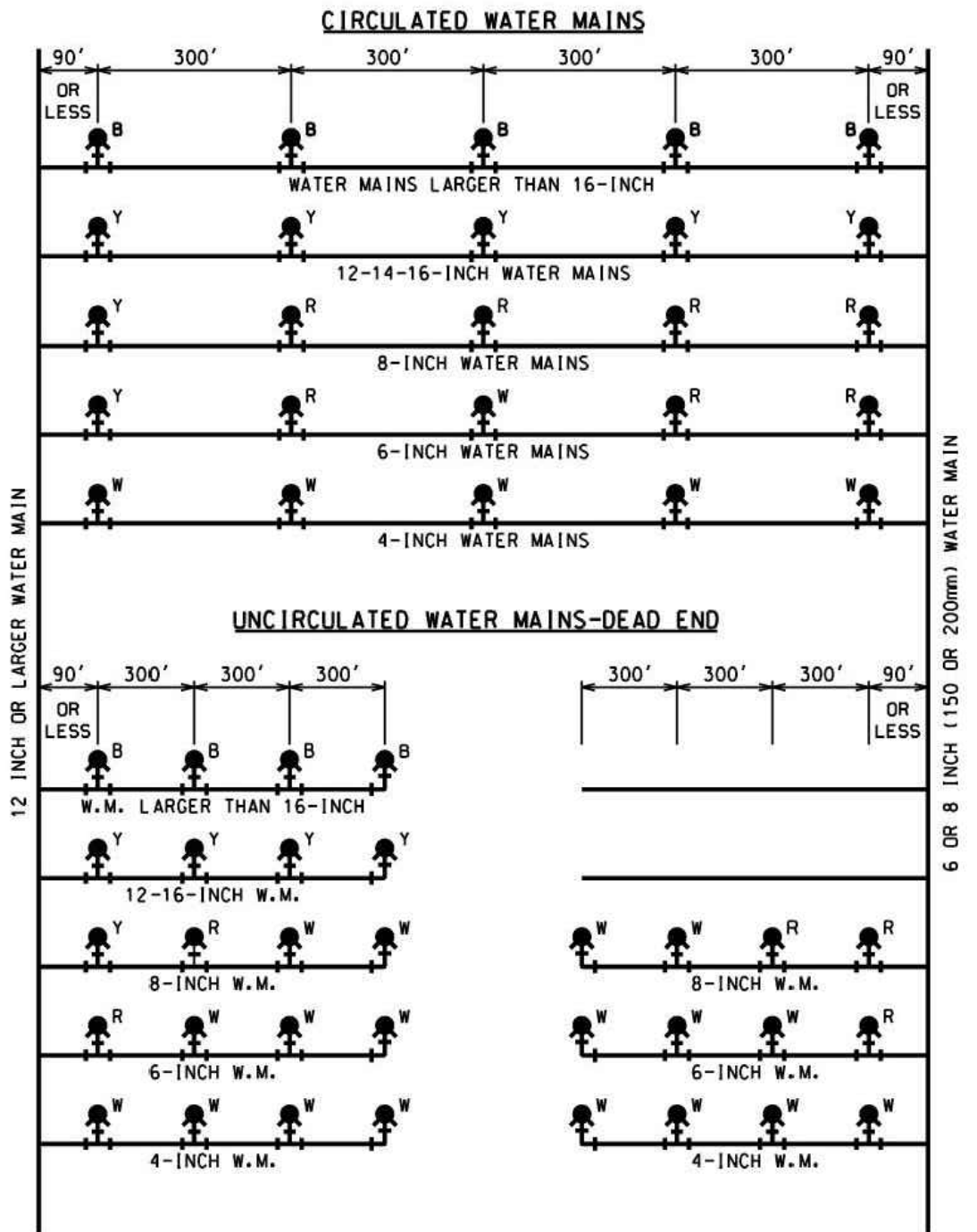

B-BLUE FLANGE Y-YELLOW FLANGE R-RED FLANGE W-WHITE FLANGE  
 ALL PUBLIC FIRE HYDRANTS ARE TO BE PAINTED RED EXCEPT FOR THE  
 TOP FLANGES WHICH MUST BE COLOR CODED.

**COLOR CODE FOR FIRE HYDRANTS**

D-7

REV:04.07

File Location: C:\Users\Emily Eng\OneDrive - Antero Group\Projects\13th Street Resurfacing\Phase I\DWG\Standards\FH-2303-DET-1.dwg Plot Date: 3/19/2024 1:28 PM Last Saved By: EMILY ENG

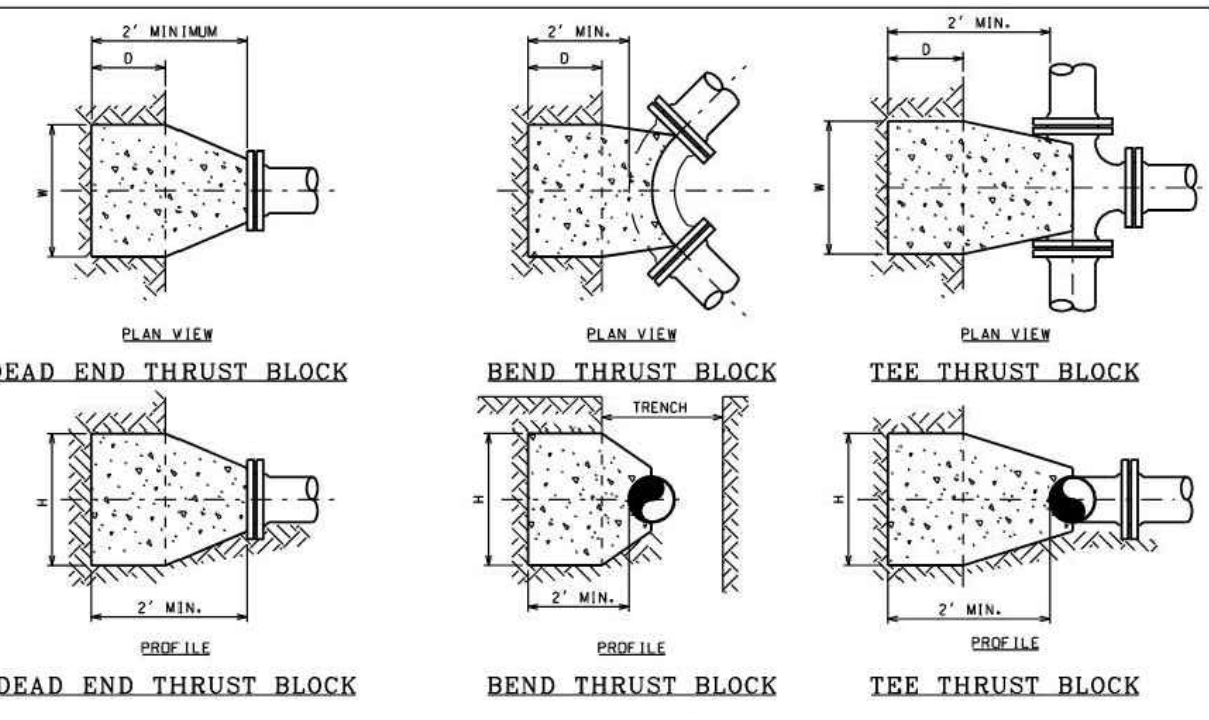

**HORIZONTAL THRUST BLOCK DETAILS**

**DEAD END THRUST BLOCK**

**DEAD END THRUST BLOCK**

**BEND THRUST BLOCK**

**BEND THRUST BLOCK**

**TEE THRUST BLOCK**

**TEE THRUST BLOCK**

**TABLE 1**

PIPE SIZE	DEAD END & TEE				HORIZONTAL 1/4 BEND				HORIZONTAL 1/8 BEND			
	D	H	W	CY	D	H	W	CY	D	H	W	CY
16	1	5.5	4.5	2	1	6.5	5	2.5	1	4.5	4	1.5
12	1	3.5	3.5	1	1	4	4	1.5	1	3	3	.75
8	.5	2.5	2.5	.5	.5	3	3	.5	.5	2	2	.3

**TABLE 2**

PIPE SIZE	HORIZONTAL 1/16 BEND				HORIZONTAL 1/32 BEND			
	D	H	W	CY	D	H	W	CY
16	1	3.5	3.5	1	1	2.5	2.5	.6
12	1	2.5	2.5	.5	1	2	2	.4
8	.5	1.5	1.5	.25	.5	1.5	1.5	.25

**TABLE 3**

PIPE SIZE	VERTICAL 1/8 BEND				VERTICAL 1/8 BEND BOTTOM			
	D	H	W	CY	D	H	W	CY
16	7	6	6	11	2	4.5	4	2.25
12	5	6	5	7	2	3	3	1
8	4.5	4	4	3.5	2	2	2	.5

**VERTICAL THRUST BLOCK DETAILS**

**NOTES:**

- FULL CONCRETE THRUST BLOCKS AS SHOWN ARE REQUIRED WHEN THRUST RESTRAINT IS NOT PROVIDED BY OTHER MEANS SUCH AS RESTRAINED JOINT PIPE.
- WHEN THRUST RESTRAINT GLANDS ARE INSTALLED FOR THE CONNECTIONS, CONCRETE THRUST BLOCKS SHALL BE PROVIDED UP TO THE THE DOTTED LINE AS SHOWN.
- ALL BOLTS, NUTS, THRUST RESTRAINT GLANDS AND FITTINGS SHALL BE WRAPPED WITH POLYETHYLENE TUBING TO PREVENT CORROSION AND CONCRETE ADHESION.
- CONCRETE FOR THRUST BLOCKS MUST NOT CONTAIN FLY ASH.

**THRUST RESTRAINT  
CONCRETE THRUST BLOCK DETAILS**

REV:04.07 D-11

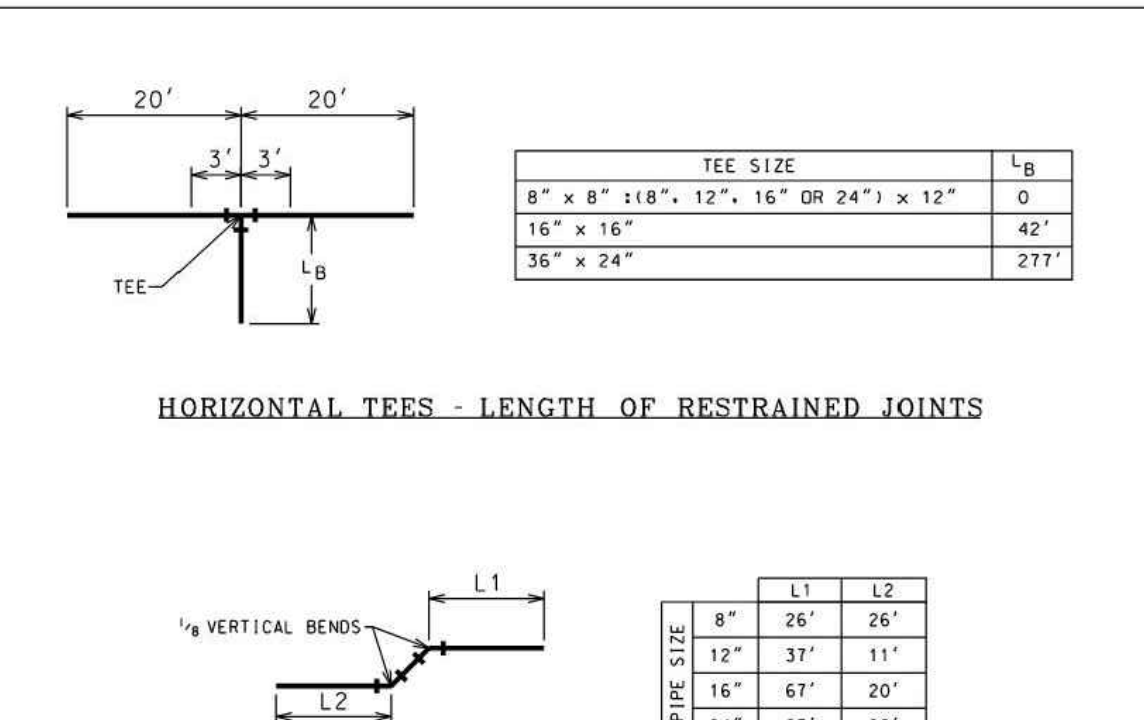

**HORIZONTAL TEES - LENGTH OF RESTRAINED JOINTS**

TEE SIZE	L <sub>B</sub>
8" x 8" : (8", 12", 16" OR 24") x 12"	0
16" x 16"	42'
36" x 24"	277'

**1/8 VERTICAL BENDS - LENGTH OF RESTRAINED JOINTS**

PIPE SIZE	L1		L2	
	8"	12"	16"	24"
8"	26'	26'	11'	20'
12"	37'	37'	20'	20'
16"	67'	67'	20'	20'
24"	67'	67'	20'	20'

**HORIZONTAL BENDS - LENGTH OF RESTRAINED JOINTS**

PIPE SIZE	DISTANCE OF RESTRAINED JOINTS REQUIRED EITHER SIDE OF BENDS			
	L			
	1/32	1/16	1/8	1/4
8"	3'	6'	12'	29'
12"	4'	8'	17'	41'
16"	7'	15'	30'	73'
24"	7'	15'	30'	73'

**THRUST RESTRAINT  
RESTRAINED JOINT PIPE DETAILS**

**NOTE:**

- MINIMUM LENGTHS OF PIPE REQUIRED TO RESTRAIN FITTINGS SHOWN.
- LENGTHS BASED ON POLY-WRAPPED PIPE.

REV:04.07 D-12



No.	DATE	REVISION DESCRIPTION

PREPARED FOR  
**VILLAGE OF FORD HEIGHTS**  
 1343 ELLIS AVENUE  
 FORD HEIGHTS, IL 60411



13TH STREET RESURFACING PROJECT  
 STANDARDS AND DETAILS  
 VILLAGE OF FORD HEIGHTS, COOK COUNTY, ILLINOIS

JOB NUMBER: FH-2303  
 DATE: 03-06-2024  
 SHEET: C-12

File Location: C:\Users\Emily.Eng\OneDrive - anterogroup.com\Documents - Antero Group\Projects\Village of Ford Heights\FH-2303\_Water System Improvements Phase I\DWG\Sheets\FH-2303-DET.dwg Plot Date: 3/19/2024 1:28 PM Last Saved By: EMILY ENG

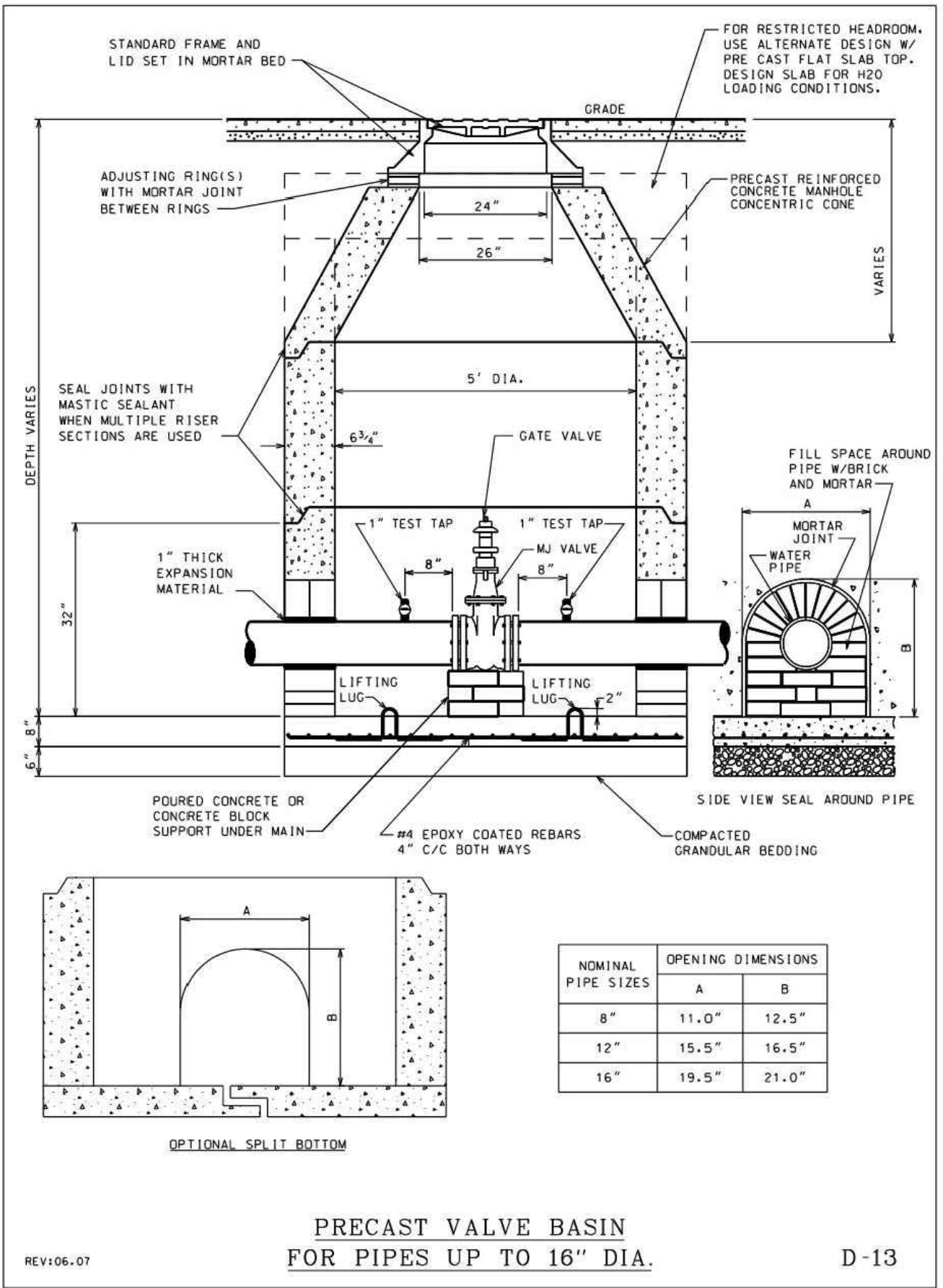

No.	DATE	REVISION DESCRIPTION

PREPARED FOR  
 VILLAGE OF FORD HEIGHTS  
 1343 ELLIS AVENUE  
 FORD HEIGHTS, IL 60411



13TH STREET RESURFACING PROJECT

STANDARDS AND DETAILS

VILLAGE OF FORD HEIGHTS, COOK COUNTY, ILLINOIS

JOB NUMBER: FH-2303  
 DATE: 03-06-2024  
 SHEET: C-13

File Location: C:\Users\Emily.Eng\OneDrive - Antero Group\Projects\Village of Ford Heights\FH-2303\_ Water System Improvements Phase II\DWG\Sheets\FH-2303-DET.dwg Plot Date: 3/19/2024 1:28 PM Last Saved By: EMILY ENG

**I. INSTALLATION**

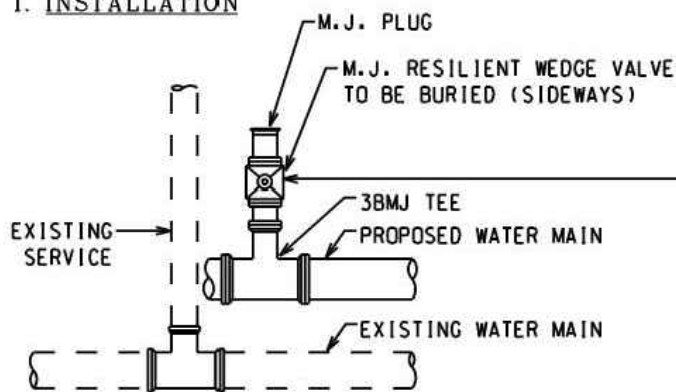

- SET: 1-4" 3BMJ TEE  
 1-8" MJ RESILIENT WEDGE VALVE  
 2-12" MJ RESTRAINT GLANDS  
 2-8" MJ RESTRAINT GLANDS  
 3' OF 8" D.I.W.P.  
 TEMPORARILY PLUG AND BRACE THE VALVE WITH: 1-8" MJ PLUG

NOTE:  
 MINIMUM 4" TEE TO BE USED FOR 3" SERVICE CONNECTION.

**II. RECONNECTION**

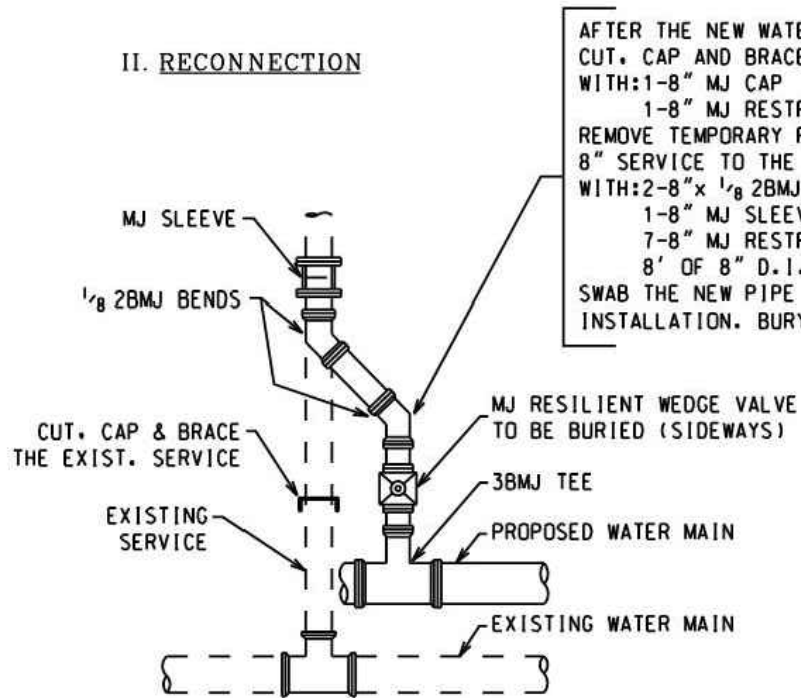

- AFTER THE NEW WATER MAIN IS APPROVED, CUT, CAP AND BRACE THE EXISTING 8" SERVICE WITH: 1-8" MJ CAP  
 1-8" MJ RESTRAINT GLAND  
 REMOVE TEMPORARY PLUG OF NOTE ABOVE AND CONNECT 8" SERVICE TO THE MJ RESILIENT WEDGE VALVE WITH: 2-8" x 1/8 2BMJ BENDS  
 1-8" MJ SLEEVE  
 7-8" MJ RESTRAINT GLANDS  
 8' OF 8" D.I.W.P.  
 SWAB THE NEW PIPE WITH HTH CHLORINE DURING THE INSTALLATION. BURY THE MJ RESILIENT WEDGE VALVE.

NOTE:  
 MECHANICAL JOINT THRUST RESTRAINT GLANDS OR APPROVED EQUIPMENT FITTINGS TO BE USED WITH ALL MJ FITTINGS.

**TYPICAL SERVICE RECONNECTION 3" AND LARGER USING M.J. RESILIENT WEDGE VALVE**

REV:04.07

D-30

FINISHED GRADE

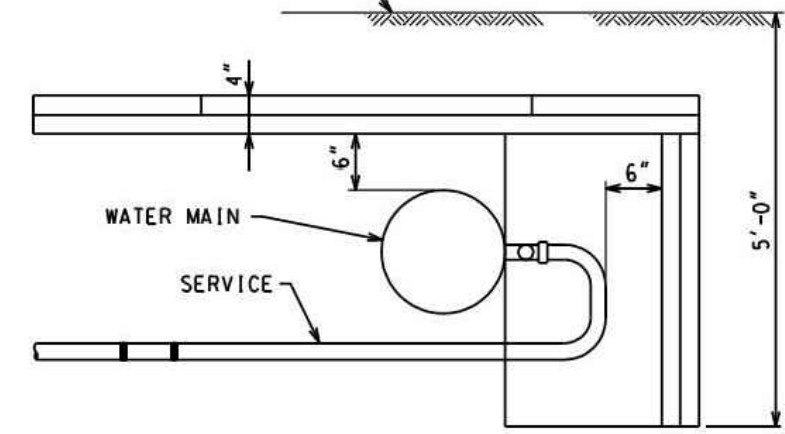

**SIDE VIEW**

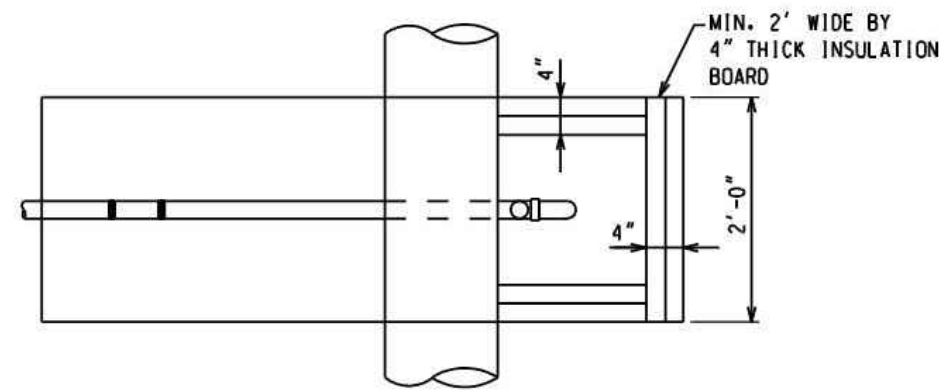

**TOP VIEW**

**SERVICE PIPE INSULATION DETAILS**

**NOTES:**

1. BACK FILL MATERIAL AROUND INSULATION SHALL BE FINE SAND (FA7), FREE FROM ROOTS, ORGANIC MATTER, LEAVES OR OTHER INJURIOUS MATERIALS.
2. OVERLAP ALL INSULATION BOARD JOINTS.
3. INSULATION BOARD TO BE CLOSED CELL, EXTRUDED POLYSTYRENE FOAM MEETING ASTM 578, TYPE VI, 40 PSI COMPRESSING STRENGTH (ASTM D1621) 0.1% MAX. WATER ABSORPTION (ASTM C272).

REV:04.07

**SERVICE PIPE INSULATION DETAILS**

D-31



No.	DATE	REVISION DESCRIPTION

PREPARED FOR  
 VILLAGE OF FORD HEIGHTS  
 1343 ELLIS AVENUE  
 FORD HEIGHTS, IL 60411

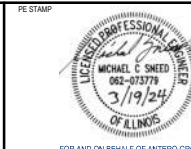

13TH STREET RESURFACING PROJECT

STANDARDS AND DETAILS

VILLAGE OF FORD HEIGHTS, COOK COUNTY, ILLINOIS

JOB NUMBER  
 FH-2303

DATE  
 03-06-2024

SHEET  
 C-14

File Location: C:\Users\Emily.Eng\OneDrive - Antero Group\Projects\13th Street Resurfacing Project\Standards and Details\FH-2303-DET.dwg Plot Date: 3/19/2024 1:28 PM Last Saved By: EMILY.ENG

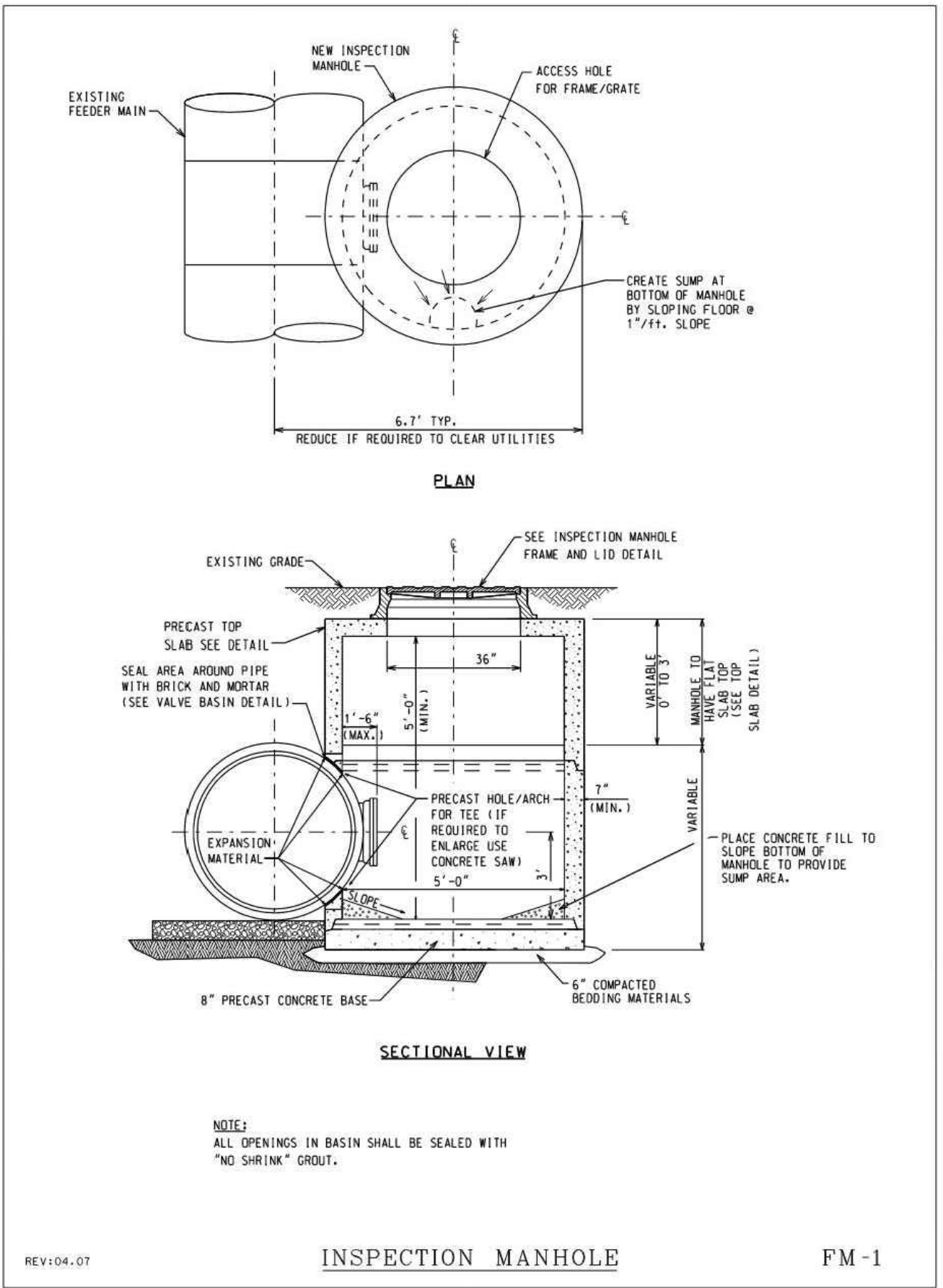

REV:04.07

**INSPECTION MANHOLE**

FM-1

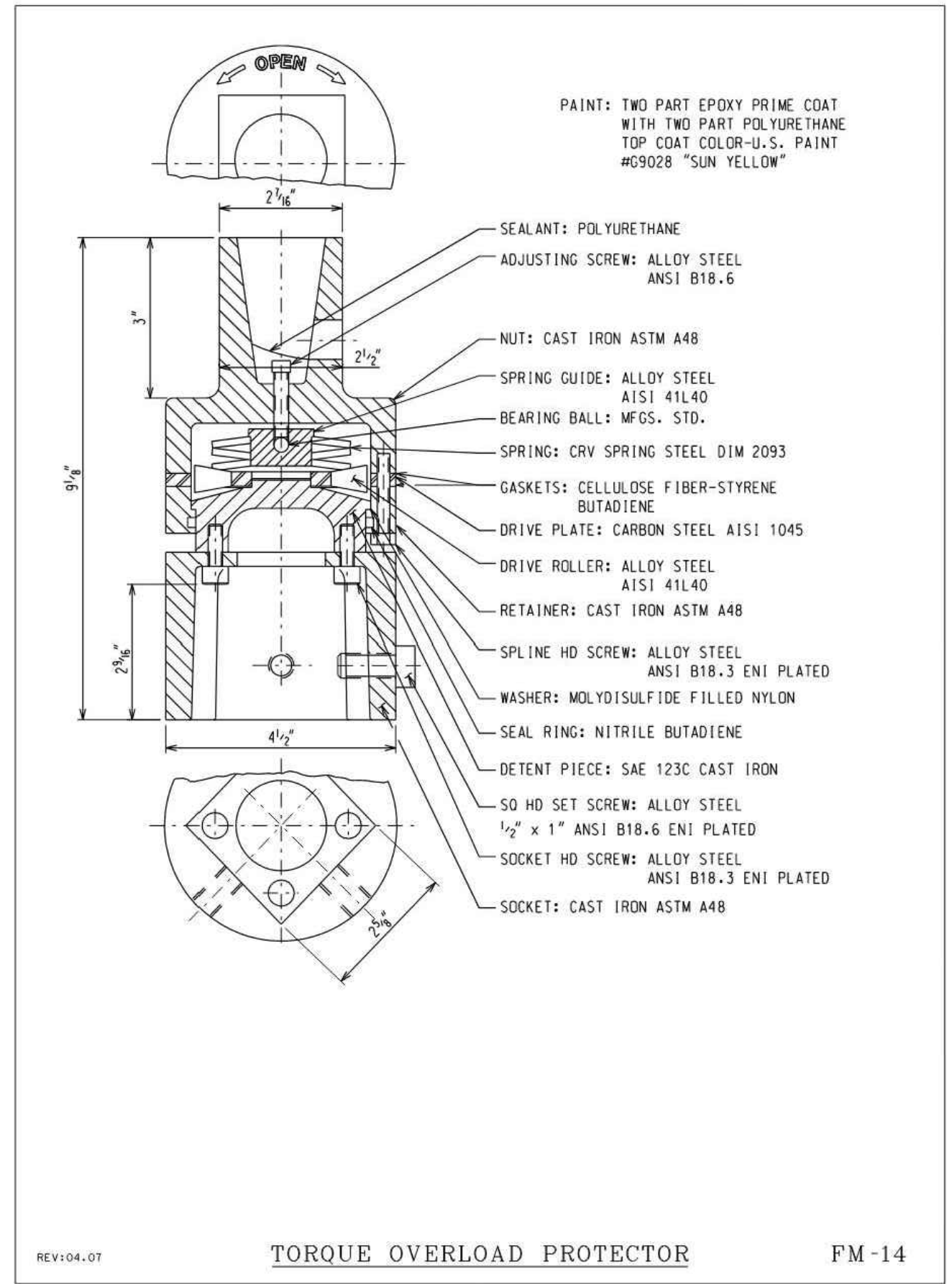

REV:04.07

**TORQUE OVERLOAD PROTECTOR**

FM-14



No.	DATE	REVISION DESCRIPTION

PREPARED FOR  
**VILLAGE OF FORD HEIGHTS**  
 1343 ELLIS AVENUE  
 FORD HEIGHTS, IL 60411



13TH STREET RESURFACING PROJECT

STANDARDS AND DETAILS

VILLAGE OF FORD HEIGHTS, COOK COUNTY, ILLINOIS

JOB NUMBER: FH-2303  
 DATE: 03-06-2024  
 SHEET: C-15

File Location: C:\Users\Emily.Eng\OneDrive - Antero Group\Projects\Village of Ford Heights\FH-2303-Water System Improvements Phase I\DWG\Sheets\FH-2303-DET-1.dwg Plot Date: 3/19/2024 1:28 PM Last Saved By: EMILY ENG

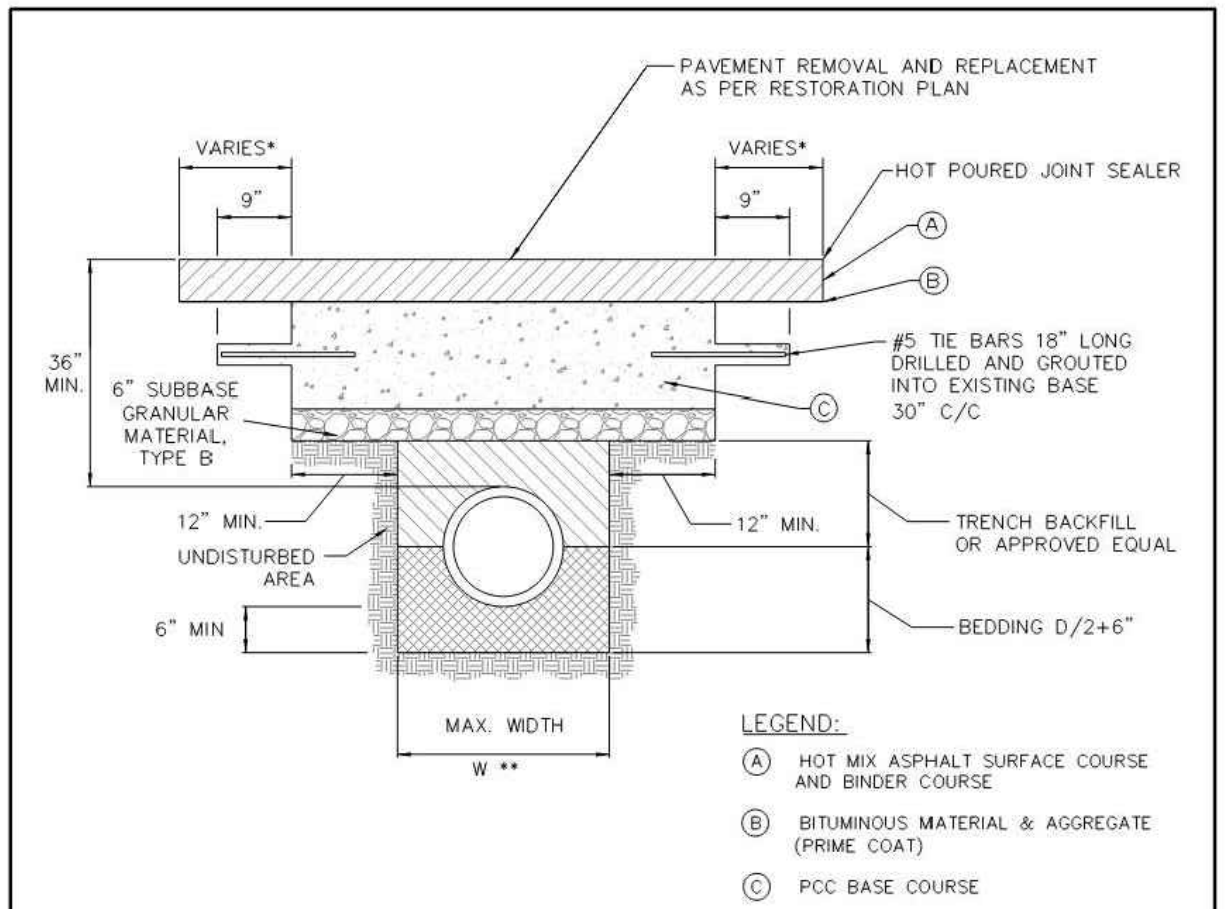

- \* PAVEMENT SHALL BE REMOVED & REPAVED TO NEAREST CONSTRUCTION JOINT IF TRENCH EDGE IS 5' OR LESS FROM JOINT. (OR AS REQUIRED BY THE COMMISSIONER)
- \*\* W = 9" + O.D. + 9", WHEN TRENCH DEPTH ≤ 5 FT.  
W = 18" + O.D. + 18", WHEN TRENCH DEPTH > 5 FT.

**NOTES:**

1. THE PORTLAND CEMENT CONCRETE BASE SHALL BE 8" OR MORE (SEE SECTION 4.2b FOR REQUIRED THICKNESS). FOR CONCRETE STREETS THE CONCRETE SHALL BE BROUGHT TO GRADE (INCLUDING 1'-0" OVERLAP) AND FINISHED AS REQUIRED IN THE IDOT SSRBC.
2. ALL EXISTING PAVEMENTS SHALL BE SAW CUT 1'-0" ON BOTH SIDES OF THE TRENCH OR PAVEMENT OPENING. UNDER NO CIRCUMSTANCES SHOULD EXISTING PAVEMENT, WHICH HAS BEEN UNDERMINED OR OTHERWISE DISTURBED, BE LEFT IN PLACE AND NOT RESTORED.
3. ALL STREET PAVEMENT WILL REQUIRE PLACEMENT OF #5 TIE BARS, 18 INCHES LONG DRILLED AND GROUTED (NON SHRINK) AT 30" CENTERS ON ALL SIDES. A MINIMUM OF TWO TIE BARS WILL BE REQUIRED ON EACH SIDE OF SAW CUT BOUNDARIES.
4. ALL TIE BARS AND DOWEL BARS ARE TO BE EPOXY COATED (INCIDENTAL).

<p>CHICAGO DEPARTMENT OF TRANSPORTATION</p>	DATE	REVISION	CITY OF CHICAGO		
	1/1/2014	REVISION 1	STREET PAVEMENT RESTORATION DETAIL WITH TRENCH BACKFILL		
	1/27/2016	REVISION 2	DATE	SHEET	DRAWN BY
			12/12/06	A-2-2A	CDOT

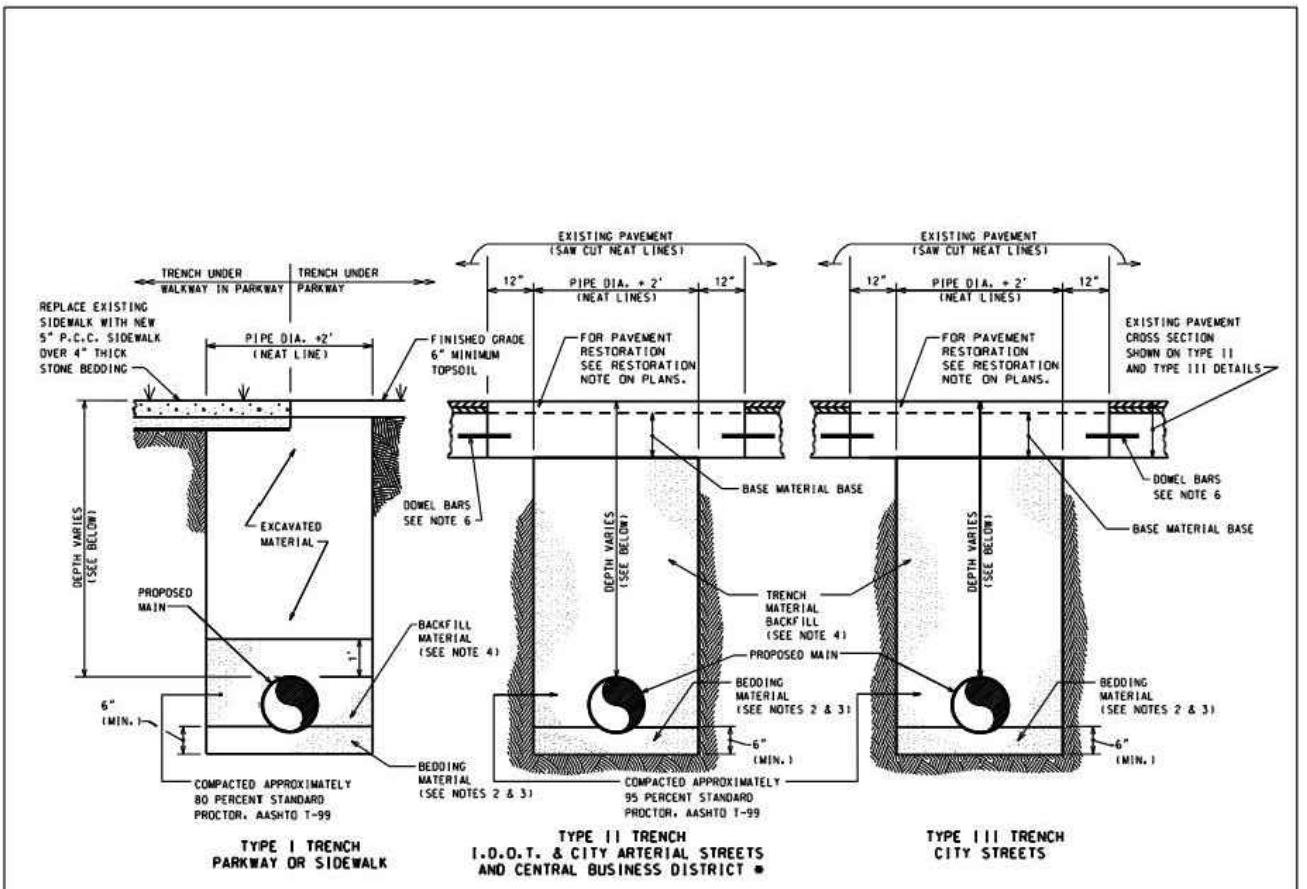

**NOTES:**

1. PROVIDE PIPE BEDDING TO A DEPTH OF 1/4 OF PIPE DIAMETER OR 6" MINIMUM OF COMPACTED GRANULAR MATERIAL, GRAVEL, OR CRUSHED STONE.
  2. USE CA-16 BEDDING MATERIAL FOR PIPE SIZES UP TO 16-INCH DIAMETER.
  3. USE CA-11 BEDDING MATERIAL FOR PIPE SIZES LARGER THAN 16-INCH DIAMETER.
  4. BACKFILL MUST BE COMPACTED UP TO ONE FOOT ABOVE THE PIPE IN TYPICAL TRENCH TYPE I AND TO THE TOP OF THE TRENCH IN TYPICAL TRENCH TYPE II & III. TRENCH BACKFILL GRADATION CA-16, EXCEPT IN CENTRAL BUSINESS DISTRICT USE CLSM (FLOWABLE FILL)
  5. ALL EXCAVATIONS MUST BE PROPERLY SHORED, SHEETED AND BRACED TO PROVIDE SAFE WORKING CONDITIONS. ALL IN COMPLIANCE WITH THE U.S. DEPARTMENT OF LABOR SAFETY AND HEALTH REGULATIONS FOR CONSTRUCTION STIPULATED UNDER THE OCCUPATIONAL SAFETY AND HEALTH ACT. (O.S.H.A.).
  6. #5 EPOXY COATED BARS, 18" LONG DRILLED AND GROUTED AT 30" CENTERS, EXCEPT OMIT ON CDDT STREETS WHERE CLSM USED AS TRENCH BACKFILL.
  7. WHEN TRENCH BACKFILL IS COMPLETE POUR CONCRETE BASE COURSE FLUSH TO TOP AND AT A MINIMUM BOTTOM OF EXISTING PAVEMENT GRADE. THE ADDITIONAL THICKNESS IS TO BE REMOVED DURING PAVEMENT RESTORATION WORK. FINAL CONCRETE BASE THICKNESS MUST BE PER C.O.D.T./I.O.D.T. REQUIREMENTS. WHEN THE THICKNESS OF THE EXISTING ROADWAY BASE MATERIAL IS LESS THAN THE MINIMUM THICKNESS NOTED BELOW, THE BOTTOM OF BASE MATERIAL WILL EXTEND BELOW THE BOTTOM OF THE BASE MATERIAL OF THE EXISTING PAVEMENT. MINIMUM THICKNESS FOR ARTERIAL STREETS IS 9 INCHES AND 7 INCHES FOR RESIDENTIAL STREET.
  8. PLATE ALL UNATTENDED EXCAVATIONS IN PAVEMENT AREAS AND SECURE PLATES TO PAVEMENT AND PROVIDE BARRIERS IN PARKWAY AREAS.
- \* CENTRAL BUSINESS DISTRICT IS DEFINED AS THE AREA FROM DIVISION STREET SOUTH TO ROOSEVELT ROAD AND HALSTED STREET EAST TO LAKE MICHIGAN.

PIPE DEPTH REQUIREMENTS	
MINIMUM DEPTH OF COVER FOR WATER MAINS	DEPTH OF COVER
SIZE OF PIPE	DEPTH OF COVER
3/4" TO 3"	5'-6" ± 3"
4"	5'-6" ± 3"
6"	5'-6" ± 3"
8"	5'-3" ± 3"
12"	5'-0" ± 2"
16"	4'-6" ± 2"
24"	4'-0" ± 1"
30" TO 42"	3'-6" MIN. (SEE PLAN)
48" & LARGER	3' MIN. (SEE PLAN)

REV:09.07

**WATER MAIN TRENCH DETAILS**

D-8



No.	DATE	REVISION DESCRIPTION

PREPARED FOR  
**VILLAGE OF FORD HEIGHTS**  
 1343 ELLIS AVENUE  
 FORD HEIGHTS, IL 60411



13TH STREET RESURFACING PROJECT  
 STANDARDS AND DETAILS  
 VILLAGE OF FORD HEIGHTS, COOK COUNTY, ILLINOIS

JOB NUMBER: FH-2303  
 DATE: 03-06-2024  
 SHEET: C-16

File Location: C:\Users\Emily.Eng\OneDrive - Antero Group\Projects\Village of Ford Heights\FH-2303-Water System Improvements Phase I\DWG\Sheets\FH-2303-DET-LWG Plot Date: 3/19/2024 1:28 PM Last Saved By: EMILY.ENG

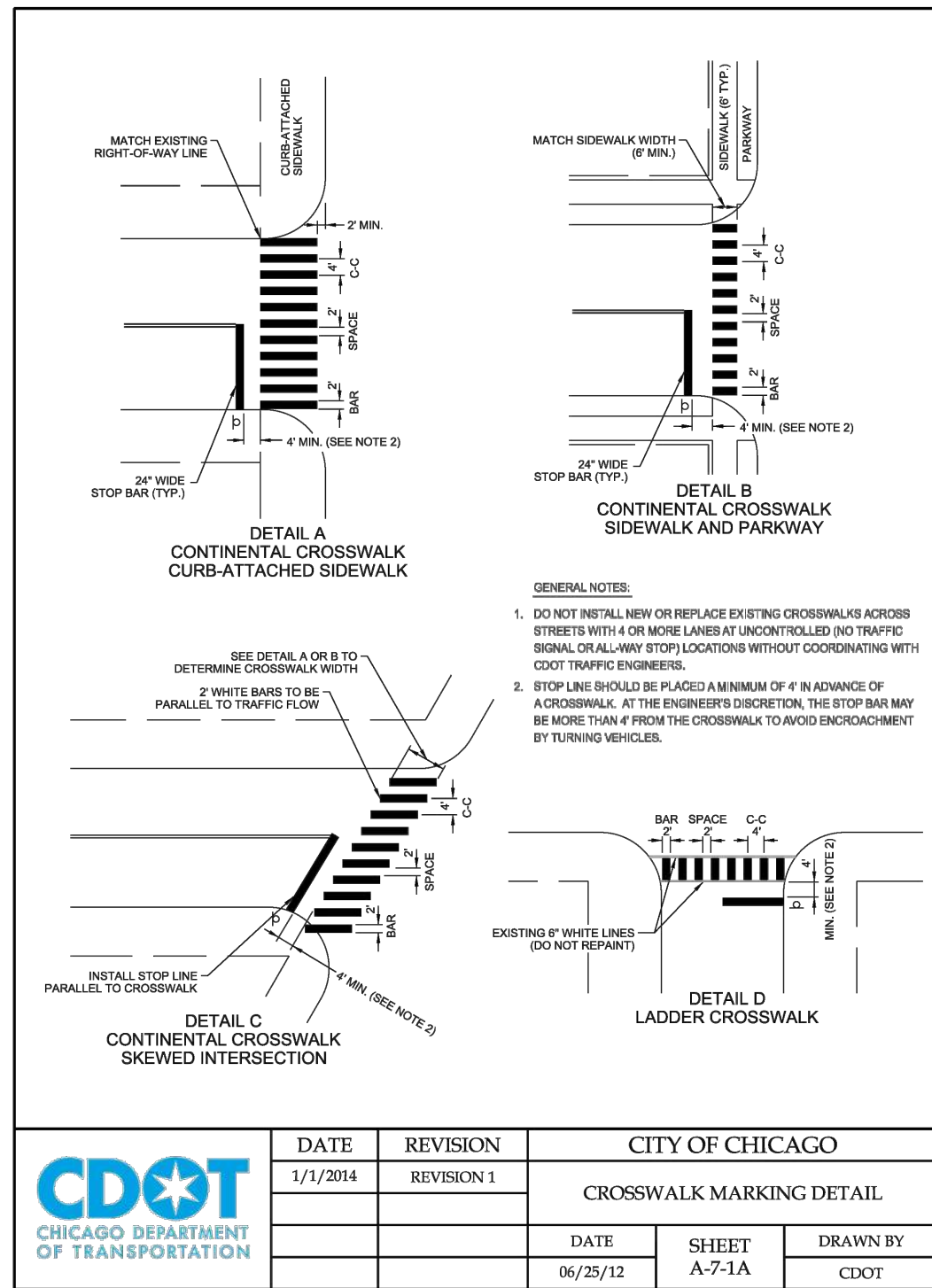

**Non-Paved Areas**

**Paved Areas**

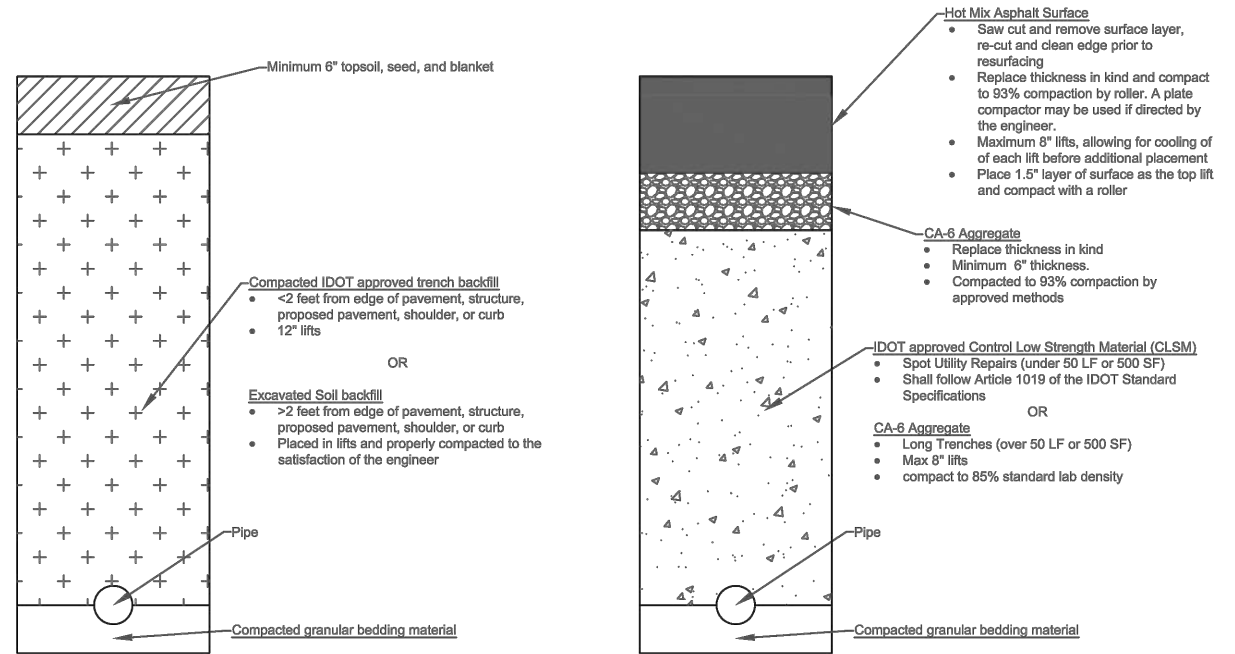

**Notes:**

- All work shall conform to IDOT's "Standard Specifications for Road & Bridge Construction" (latest edition) and "Supplemental Specifications and Recurring Special Provisions" (latest edition)
- Replace all raised reflective pavement markers, striping, letters, symbols, detector loops, wires, and other appurtenances in kind
- The Engineer may select the backfill requirement based on site conditions
- All out of service facilities in the ROW shall be removed



No.	DATE	REVISION DESCRIPTION

PREPARED FOR  
**VILLAGE OF FORD HEIGHTS**  
 1343 ELLIS AVENUE  
 FORD HEIGHTS, IL 60411



**13TH STREET RESURFACING PROJECT**

STANDARDS AND DETAILS

VILLAGE OF FORD HEIGHTS, COOK COUNTY, ILLINOIS

JOB NUMBER  
FH-2303  
 DATE  
03-06-2024  
 SHEET  
C-17



File Location: C:\Users\Emily.Eng\OneDrive - Antero Group\Projects\Village of Ford Heights\FH-2303\_ Water System Improvements Phase II\DWG\Sheets\FH-2303-DET.Lwg Plot Date: 3/19/2024 1:28 PM Last Saved By: EMILY.ENG

**GENERAL NOTES**

All catch basins shall be separated from the pavement and curb by boxing out as shown in the detail. Manhole castings within the pavement limits shall be boxed in a like manner except when telescoping type castings are used.

When a joint falls within 5 ft. (1.5 m) of or contacts basins, manholes, or other structures, shorten one or more panels either side of opening to permit joint to fall at the corners of the box out.

When specified, roundouts as shown on Standard 420111 shall be used in lieu of the manhole detail shown herein except No. 5 (No. 16) bars shall be used in lieu of No. 6 (No. 19) bars.

All transverse joints must extend through curbs and be continuous across pavement, except tied transverse construction joints. Expansion joints will be required as shown on the plans.

When specified, the pavement structure thickness at intersections shall be increased. This requirement generally will occur when the design traffic through the intersection exceeds the typical design of the pavement structure either side of the intersection.

Joints shall be sawed to a depth of t/4 for transverse joints and t/3 for longitudinal joints. Saw joints shall be sealed with material meeting the requirements of Section 1050 of the Standard Specifications.

This alternate construction is at the Contractor's option and shall be constructed in accordance with Section 606 of the Standard Specifications. The combination concrete curb and gutter shall be measured in place and the area computed in sq. yards (sq. meters). This work will be paid for at the contract unit price per sq. yards (sq. meters) for portland cement concrete pavement special with integral curb of the thickness specified and shall include all materials and labor.

Transverse joint spacing shall not exceed 15 ft. (4.6 m).

Construct TYPE D tied transverse construction joint when construction joint does not fall at a TYPE C sawed transverse joint.

Illinois Department of Transportation

APPROVED January 1, 2018  
*Michael C. Sneed*  
 ENGINEER OF LOCAL ROADS AND STREETS

APPROVED January 1, 2018  
*Matthew M. DeLo*  
 ENGINEER OF DESIGN AND ENVIRONMENT

46 E-1 GANSE

**PCC PAVEMENT SPECIAL  
 (NONREINFORCED)**

(Sheet 2 of 2)

**STANDARD B.L.R. 10-7**

No.	DATE	REVISION DESCRIPTION

PREPARED FOR

VILLAGE OF FORD HEIGHTS  
 1343 ELLIS AVENUE  
 FORD HEIGHTS, IL 60411



13TH STREET RESURFACING PROJECT

STANDARDS AND DETAILS

VILLAGE OF FORD HEIGHTS, COOK COUNTY, ILLINOIS

JOB NUMBER: FH-2303

DATE: 03-06-2024

SHEET: C-18



File Location: C:\Users\Emily.Eng\OneDrive - Antero Group\Projects\Village of Ford Heights\FH-2303\_Water System Improvements Phase II\DWG\Sheets\FH-2303-DET.dwg Plot Date: 3/19/2024 1:27 PM Last Saved By: EMILY ENG

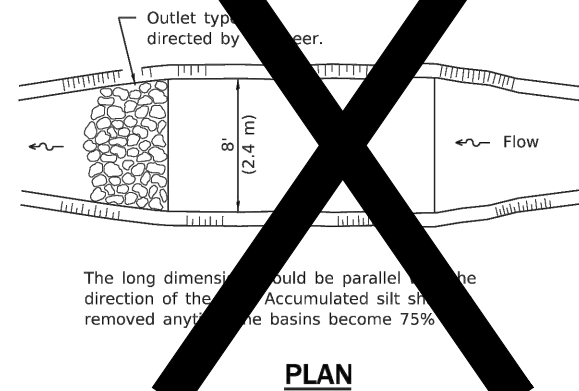
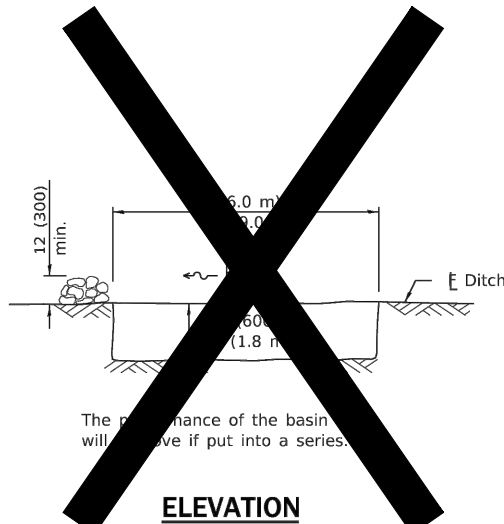
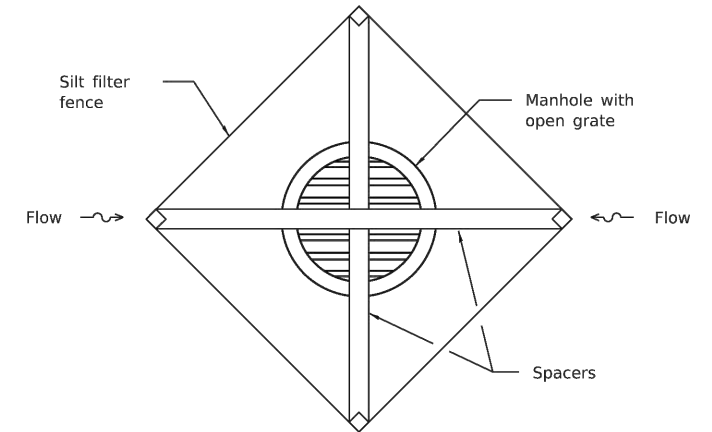
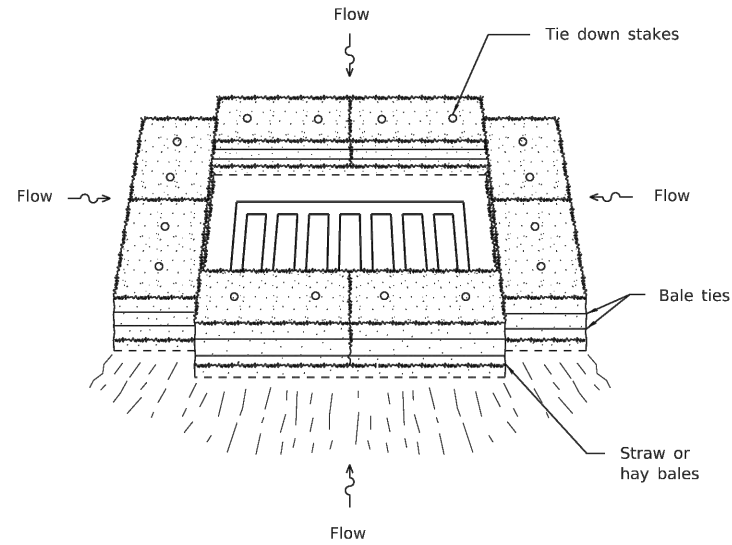
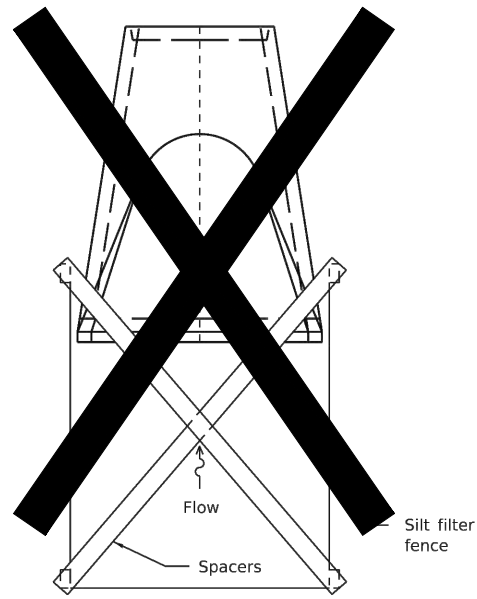
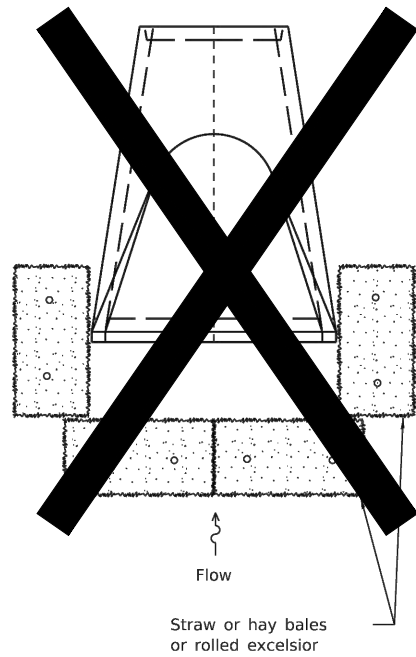

**INLET AND PIPE PROTECTION**

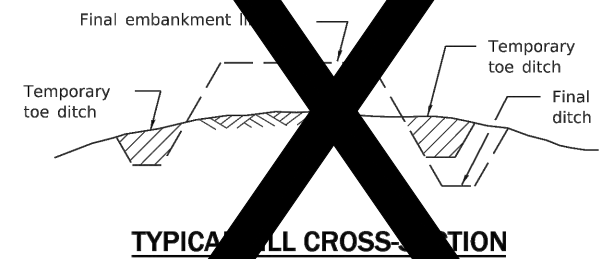
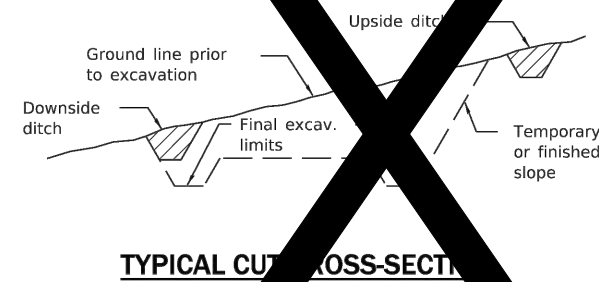

**TEMPORARY DITCHES FOR CUT & FILL SECTIONS**

**SEDIMENT BASIN**

Illinois Department of Transportation	
PASSED January 1, 2013  ENGINEER OF POLICY AND PROCEDURES	ISSUED 1.1.97
APPROVED January 1, 2013  ENGINEER OF DESIGN AND ENVIRONMENT	

<b>TEMPORARY EROSION CONTROL SYSTEMS</b> (Sheet 2 of 2)
<b>STANDARD 280001-07</b>



No.	DATE	REVISION DESCRIPTION

PREPARED FOR  
 VILLAGE OF FORD HEIGHTS  
 1343 ELLIS AVENUE  
 FORD HEIGHTS, IL 60411



13TH STREET RESURFACING PROJECT  
 STANDARDS AND DETAILS  
 VILLAGE OF FORD HEIGHTS, COOK COUNTY, ILLINOIS

JOB NUMBER: FH-2303  
 DATE: 03-06-2024  
 SHEET: C-19

# **APPENDIX D**

**(Bid Form)**



Appendix D: Bid Form

Village of Ford Heights Water System Improvement Project Phase II  
Bid Form

13 <sup>th</sup> Street Hydrant Replacement, Watermain Spot Repairs and Resurfacing				
Description	Quantity	Unit	Unit Cost	Total Cost
Mobilization	1	LS		
Remove Fire Hydrant	4	Each		
4" Hot-Mix Asphalt Surface Removal	7795	Sq Yd		
Fire Hydrant	2	Each		
Hot-Mix Asphalt Surface Course, Mix D, N50, 1.5"	658	Tons		
Hot-Mix Asphalt Binder Course, IL-19.0 N50, 2.5" Lift	1089	Tons		
Bituminous Material Tack Coat	780	Gal		
Bituminous Material Prime Coat	2339	Gal		
Inlet Protection	12	Each		
Clean out Storm Structure	12	Each		
Grind 2'-wide Stop Bar	36	Feet		
2'-Wide Thermoplastic Pavement Marking	102	Foot		



Locate, Repair, and Sleeve 6" Water Main Leak	1	Each		
Locate, Repair, and Sleeve 10" Water Main Leak	1	Each		
Traffic Control	1	LS		
<b>Total</b>				

\*Quantities are provided for information only. Contractor to verify in field and with information provided on Plans.

By signing below, the Bidder acknowledges the following:

1. The Bidder has familiarized itself with the existing conditions of the project area and with the Contract Documents.
2. The Bidder offers to perform all the work specified in the Contract Documents for the prices proposed above.
3. The Bidder has independently verified the quantities set forth above and in the plans and specifications and isunaware of any significant errors or discrepancies.

Respectfully submitted,

By (signature): \_\_\_\_\_

Name: \_\_\_\_\_

Title: \_\_\_\_\_

Company: \_\_\_\_\_

Date: \_\_\_\_\_

